

ANSYS 2025/R1

POWERING INNOVATION THAT DRIVES HUMAN ADVANCEMENT

© 2025 ANSYS, Inc. or its affiliated companies
Unauthorized use, distribution, or duplication is prohibited.

ACP User's Guide



ANSYS, Inc.
Southpointe
2600 Ansys Drive
Canonsburg, PA 15317
ansysinfo@ansys.com
<http://www.ansys.com>
(T) 724-746-3304
(F) 724-514-9494

Release 2025 R1
January 2025

ANSYS, Inc. and
ANSYS Europe,
Ltd. are UL
registered ISO
9001:2015
companies.

Copyright and Trademark Information

© 2025 ANSYS, Inc. Unauthorized use, distribution or duplication is prohibited.

ANSYS, Ansys Workbench, AUTODYN, CFX, FLUENT and any and all ANSYS, Inc. brand, product, service and feature names, logos and slogans are registered trademarks or trademarks of ANSYS, Inc. or its subsidiaries located in the United States or other countries. ICEM CFD is a trademark used by ANSYS, Inc. under license. CFX is a trademark of Sony Corporation in Japan. All other brand, product, service and feature names or trademarks are the property of their respective owners. FLEXIm and FLEXnet are trademarks of Flexera Software LLC.

Disclaimer Notice

THIS ANSYS SOFTWARE PRODUCT AND PROGRAM DOCUMENTATION INCLUDE TRADE SECRETS AND ARE CONFIDENTIAL AND PROPRIETARY PRODUCTS OF ANSYS, INC., ITS SUBSIDIARIES, OR LICENSORS. The software products and documentation are furnished by ANSYS, Inc., its subsidiaries, or affiliates under a software license agreement that contains provisions concerning non-disclosure, copying, length and nature of use, compliance with exporting laws, warranties, disclaimers, limitations of liability, and remedies, and other provisions. The software products and documentation may be used, disclosed, transferred, or copied only in accordance with the terms and conditions of that software license agreement.

ANSYS, Inc. and ANSYS Europe, Ltd. are UL registered ISO 9001: 2015 companies.

U.S. Government Rights

For U.S. Government users, except as specifically granted by the ANSYS, Inc. software license agreement, the use, duplication, or disclosure by the United States Government is subject to restrictions stated in the ANSYS, Inc. software license agreement and FAR 12.212 (for non-DOD licenses).

Third-Party Software

See the [legal information](#) in the product help files for the complete Legal Notice for ANSYS proprietary software and third-party software. If you are unable to access the Legal Notice, contact ANSYS, Inc.

Published in the U.S.A.

Table of Contents

1. Getting Started	1
1.1. Overview	1
1.1.1. Introduction	1
1.1.2. Supported Platforms and Functional Add-ons	3
1.1.3. Known Limitations	3
1.1.4. First Steps	5
1.2. The Ansys Product Improvement Program	5
1.3. Graphical User Interface	9
1.3.1. Menus	10
1.3.1.1. File	10
1.3.1.1.1. Workbench	11
1.3.1.1.2. Stand Alone	11
1.3.1.2. View	12
1.3.1.2.1. Perspectives	12
1.3.1.2.2. View Manager	13
1.3.1.3. Tools	13
1.3.1.3.1. Extract Materials From Composite CAE H5... ..	14
1.3.1.3.2. Winding Wizard	14
1.3.1.3.3. Migration Helper	16
1.3.1.3.4. Preferences	16
1.3.1.3.4.1. Add Ons	17
1.3.1.3.4.2. Ansys Product Improvement Program	17
1.3.1.3.4.3. General ACP Preferences	17
1.3.1.3.4.4. Logger Settings	18
1.3.1.3.4.5. Material Database	18
1.3.1.3.4.6. Notifications and Pop-ups	19
1.3.1.3.4.7. Scene Preferences	19
1.3.1.3.4.8. Section Generation	20
1.3.1.3.4.9. Units	20
1.3.2. Tree View	21
1.3.3. Scene	23
1.3.3.1. Scene Manipulation	23
1.3.4. Toolbar	23
1.3.4.1. Updates	24
1.3.4.2. Edit Entities with Excel	24
1.3.4.3. Scene Options	25
1.3.4.4. Mesh Appearance	26
1.3.4.5. Orientation Visualization	26
1.3.4.6. Fiber Directions	28
1.3.4.7. Draping	29
1.3.4.8. Other Features	32
1.3.4.9. Configure Plots	33
1.3.5. View Panes	34
1.3.5.1. Shell View	34
1.3.5.2. Keyboard Shortcuts	35
1.3.5.3. Logger	35
1.3.5.4. History View	36
1.3.6. Keyboard Shortcuts	36
1.3.6.1. General Shortcuts	36

1.3.6.2. Scene View Shortcuts	36
1.3.6.3. Tree View Shortcuts	37
1.3.6.4. Shell View	37
1.3.6.5. Properties Windows	38
1.4. Implementation in Workbench	38
1.4.1. Basic Workflow	39
1.4.1.1. Transfer Types	42
1.4.2. ACP Component Properties	42
1.4.3. Supported Analysis Types	44
1.4.3.1. ACP-LS-DYNA	45
1.4.4. Multiple Load Cases and Analyses	47
1.4.5. Shared Composite Definition for Different Models	47
1.4.6. Solid Modeling	48
1.4.7. Assembly	50
1.4.7.1. Renumbering and Transfer Type	51
1.4.7.2. Creating a Mixed Assembly	51
1.4.8. Limitations	52
1.5. Migrating ACP Projects from Previous Versions	53
1.6. The ACP Python Scripting User Interface	56
1.7. Stand Alone Operation	56
1.7.1. Starting ACP in Windows	57
1.7.2. Starting ACP in Linux	57
1.7.3. Command Line Options and Batch Mode	57
1.7.4. Workflow in Stand Alone Operation	58
1.8. Tutorials and Examples	59
2. Usage Reference	61
2.1. Features	61
2.1.1. Model	62
2.1.1.1. Model Properties - General	63
2.1.1.1.1. ACP Model	65
2.1.1.1.2. Reference Surface	65
2.1.1.1.3. Lay-Up Computation	65
2.1.1.1.4. Model Summary	66
2.1.1.2. Solve	66
2.1.1.3. Import/Export of ACP Composite Definitions File	67
2.1.1.4. Import From/Export to HDF5 Composite CAE File	68
2.1.1.5. Import Section Data from Legacy Model	68
2.1.1.6. Element- vs. Node-based Thicknesses	68
2.1.1.7. Winding Wizard	71
2.1.2. Scripts	71
2.1.2.1. Executing Scripts	72
2.1.2.2. Script Properties	72
2.1.2.3. Limitations	73
2.1.2.4. Tips and Best Practices	73
2.1.2.5. Sorting Scripts	74
2.1.3. Material Data	74
2.1.3.1. Materials	75
2.1.3.1.1. Materials Context Menu	75
2.1.3.1.2. Temperature Dependent and General Variable Material Properties	75
2.1.3.1.3. Material Properties Dialog	76
2.1.3.1.4. Thermal Expansion Coefficients	78

2.1.3.1.5. Fabric Fiber Angle	78
2.1.3.1.6. Strain Limits	79
2.1.3.1.7. Stress Limits	80
2.1.3.1.8. Puck Constants	81
2.1.3.1.9. Puck for Woven	82
2.1.3.1.10. Tsai-Wu Constants	83
2.1.3.1.11. LaRC Constants	84
2.1.3.2. Fabric	84
2.1.3.2.1. General	85
2.1.3.2.2. Polar Properties	85
2.1.3.2.3. Fabric Solid Model Options	86
2.1.3.2.4. Draping	87
2.1.3.3. Stackup	88
2.1.3.3.1. Top-Down or Bottom-Up Sequence	89
2.1.3.3.2. Symmetries	89
2.1.3.3.3. Analysis	91
2.1.3.3.4. Stackup Solid Model Options	93
2.1.3.3.5. Draping Options	93
2.1.3.4. Sublaminates	93
2.1.4. Element and Edge Sets	94
2.1.4.1. Element Sets	95
2.1.4.1.1. Context Menu	96
2.1.4.2. Edge Sets	96
2.1.5. Geometry	97
2.1.5.1. CAD Geometries	99
2.1.5.1.1. Direct Import	100
2.1.5.1.2. Workbench Geometry Link	101
2.1.5.2. Virtual Geometries	101
2.1.6. Rosettes	103
2.1.6.1. Rosette Definition	106
2.1.7. Look-Up Tables	107
2.1.7.1. 3D Look-Up Table With The Excel Link	107
2.1.7.2. 1D Look-Up Table with .csv Files	109
2.1.7.3. Look-Up Table with a Python Script	111
2.1.7.4. 1-D Look-Up Table	112
2.1.7.5. 3D Look-Up Table	112
2.1.7.6. Look-Up Table Column Properties	114
2.1.8. Selection Rules	115
2.1.8.1. Basic Selection Rules	116
2.1.8.2. Tube Selection Rule	118
2.1.8.3. Cut-Off Selection Rules	120
2.1.8.3.1. Geometry Cut-Off Selection Rule	121
2.1.8.3.2. Taper Cut-Off Selection Rule	123
2.1.8.3.3. Example Cut-Off	124
2.1.8.4. Geometrical Selection Rule	125
2.1.8.5. Variable Offset Selection Rule	128
2.1.8.6. Boolean Selection Rules	131
2.1.9. Oriented Selection Sets (OSS)	132
2.1.9.1. Reference Direction	134
2.1.9.1.1. Use Cases for Rotation Angle	135
2.1.9.2. Selection Rules	137

2.1.9.3. Draping	137
2.1.10. Modeling Groups	139
2.1.10.1. Modeling Group Structure	139
2.1.10.2. Modeling Group Tree Object Context Menu	140
2.1.10.3. Individual Modeling Group Context Menu	140
2.1.10.4. Modeling Ply Properties	142
2.1.10.4.1. Draping	142
2.1.10.4.2. Selection Rules	145
2.1.10.4.3. Thickness	146
2.1.10.4.4. Modeling Ply Context Menu	149
2.1.10.5. Interface Layer Properties	151
2.1.10.6. Butt Joint Sequence	153
2.1.10.6.1. Butt Joint Sequence Notes and Limitations	155
2.1.10.7. Reordering Modeling Plies, Interface Layers, and Butt Joint Sequences	155
2.1.10.8. Production Ply	156
2.1.10.9. Analysis Ply	156
2.1.10.10. Import from / Export to CSV File	157
2.1.10.10.1. Export	157
2.1.10.10.2. Import	157
2.1.10.11. Export Ply Geometry	158
2.1.11. Imported Modeling Group	159
2.1.11.1. Tree Object Context Menu	159
2.1.11.2. Imported Modeling Ply	160
2.1.11.2.1. Imported Modeling Ply Properties	161
2.1.11.3. Imported Production Ply	164
2.1.11.4. Imported Analysis Ply	164
2.1.12. Field Definitions	165
2.1.13. Sampling Points	168
2.1.14. Section Cuts	170
2.1.14.1. Types of Extrusion	173
2.1.14.2. Section Cut Notes	175
2.1.14.3. Section Cut Export	175
2.1.14.4. Computation of Equivalent Sectional Properties	176
2.1.14.4.1. Theory	178
2.1.14.4.2. Results	179
2.1.14.4.3. Best Practices	180
2.1.14.4.4. Limitations	181
2.1.14.4.5. References	181
2.1.15. Sensors	181
2.1.16. Solid Models	183
2.1.16.1. Solid Model	184
2.1.16.1.1. Properties	185
2.1.16.1.1.1. General	185
2.1.16.1.1.2. Drop-Offs	189
2.1.16.1.1.3. Export	191
2.1.16.1.2. Export Solid Model	194
2.1.16.1.3. Extrusion Guides	195
2.1.16.1.3.1. Mesh Morphing	197
2.1.16.1.3.2. Extrusion Guide Examples	198
2.1.16.1.4. Snap-To Geometry	200
2.1.16.1.5. Cut-Off Geometry	202

2.1.16.1.5.1. Defining Cut-Off Geometry	203
2.1.16.1.5.2. Decomposition of Degenerated Elements	205
2.1.16.1.5.3. Limitations	205
2.1.16.1.6. Mesh Components	206
2.1.16.1.7. Material Handling for Different Extrusion Methods	207
2.1.16.1.8. Save & Reload Solid Models	207
2.1.16.1.9. Node-based Thicknesses	207
2.1.16.2. Imported Solid Model	208
2.1.16.2.1. Imported Solid Model Properties	209
2.1.16.2.1.1. General Tab	210
2.1.16.2.1.2. Export Tab	211
2.1.16.2.1.3. Mapping Statistics	211
2.1.16.2.2. Mesh Components	211
2.1.16.2.3. Lay-up Mapping Objects	212
2.1.16.2.3.1. General Tab	212
2.1.16.2.3.2. Layered Element Tab	215
2.1.16.2.3.2.1. Limitations	218
2.1.16.2.3.3. Reinforcing Tab	219
2.1.16.2.3.3.1. Design Tips and Best Practices	220
2.1.16.2.3.3.2. Limitations	220
2.1.16.2.4. Quality Check	221
2.1.16.2.5. Miscellaneous	221
2.1.17. Lay-Up Plots	222
2.1.17.1. Interface Options	223
2.1.17.2. Thickness Plots	226
2.1.17.3. Angle Plot	227
2.1.17.4. Draping Mesh Plot	227
2.1.17.5. Look-Up Table Plot	229
2.1.17.6. Field Definition Plot	231
2.1.17.7. Lay-Up Mapping Plot	231
2.1.17.8. Material Plots	233
2.1.17.9. User-Defined Plot	233
2.1.18. Scenes	233
2.1.19. Views	233
2.1.20. Ply Books	234
2.1.20.1. Creating Chapters	234
2.1.20.2. Chapter Properties	235
2.1.20.3. Editing the Ply Book Template	235
2.1.20.3.1. Python Expressions	237
2.1.20.4. Modifying the Ply Book Snapshots	238
2.1.20.5. Exporting the Plybook	238
2.1.20.6. Sample Ply Book Page	239
2.1.20.7. Ply Book Limitations	241
2.1.21. Parameters	241
2.1.21.1. Settings for an Expression Output	243
2.1.22. Material Database	244
2.2. Exchanging Composite Definitions with Other Programs	245
2.2.1. HDF5 Composite CAE Format	245
2.2.1.1. Export	246
2.2.1.2. Import	248
2.2.1.2.1. Import Projection Types	249

2.2.1.2.2. Import Settings	250
2.2.2. Mechanical APDL File Format	252
2.2.3. Import of Legacy Mechanical APDL Composite Models	254
2.2.3.1. Special Cases	256
2.2.3.2. Known Limitations	257
2.2.4. Tabular Data Format for Excel	257
2.2.5. CSV Format	258
2.2.6. ESAComp	258
2.2.6.1. Export	259
2.2.6.2. Import	259
2.2.7. LS-Dyna	259
2.2.8. BECAS	260
3. Composite Modeling Techniques	261
3.1. T-Joint	261
3.2. Local Reinforcements	267
3.3. Ply Tapering and Staggering	269
3.3.1. Ply Tapering	269
3.3.1.1. Edge Tapering	269
3.3.1.2. Tapered Core	270
3.3.1.3. Tapered Edges	270
3.3.1.4. Tapering of Multiple Plies	272
3.3.2. Ply Staggering	272
3.4. Variable Core Thickness	273
3.4.1. Solid CAD Geometry	274
3.4.2. Look-Up Table	275
3.4.3. Geometry Cut-Off Selection Rule	277
3.4.4. General Application	278
3.5. Draping	279
3.5.1. Internal Draping Algorithm of ACP	279
3.5.2. User-Defined Draping	281
3.5.3. Visualization	282
3.6. Guide to Solid Modeling	283
3.6.1. When to Use a Solid Model	284
3.6.2. How to Use the Solid Model Feature	284
3.6.3. Principles of Solid Model Generation	285
3.6.4. Drop-Off and Cut-Off Elements	285
3.6.5. Workflow	286
3.6.6. Practical Tips	287
3.6.7. Known Limitations	288
3.7. Guide to Composite Visualizations	290
3.7.1. Model Verification	290
3.7.2. Postprocessing Visualizations	291
3.8. Guide to Composite Failure Criteria	301
3.9. Element Choice in ACP	302
3.9.1. Introduction	302
3.9.2. Shell Elements	302
3.9.3. Solid Elements	302
3.9.4. Solid-shell Elements	303
3.10. Variable Material Data in Composite Analyses	303
3.10.1. Element- or Layer-wise Field Definition	303
3.10.2. Draping Shear	304

3.10.3. Degradation Factors	304
3.10.3.1. Definition of the Degradation Factor Field	305
3.10.4. Definition of General User-Defined Fields in ACP (Pre)	305
3.10.5. Variable Data Interpolation Settings	305
4. Example Analyses	307
4.1. Analysis of a Composite Shell Model	307
4.1.1. Preprocessing	308
4.1.1.1. Workbench Integration	308
4.1.1.2. Adding ACP Components to the Project	308
4.1.1.3. Engineering Data	309
4.1.1.4. Properties	310
4.1.1.5. Geometry and Units	312
4.1.1.6. Named Selections and Elements/Edge Sets	312
4.1.1.7. Starting and Running ACP	312
4.1.2. Workbench: Adding an Analysis System to the Project	313
4.1.3. Postprocessing	314
4.2. Analysis of a Composite Solid Model	314
4.2.1. Preprocessing	315
4.2.2. Workbench Application Analysis System	316
4.2.3. Postprocessing	320
4.3. Analysis Using Variable Material Data	320
4.3.1. Workbench Application Engineering Data: Set-Up Variable Data	321
4.3.2. ACP (Pre): Define Fields for Shear Angle, Degradation Factor, and User-Defined Field Variables	324
4.3.3. Mechanical, Thermal Loading, and External Data	325
4.3.4. Postprocessing in Mechanical Application: Analysis Effect of Variable Data	326
4.4. Analysis of a Mapped Composite Solid Model	326
4.4.1. Transfer External Solid Mesh to ACP (Pre)	328
4.4.1.1. Geometry	328
4.4.1.2. Meshing	329
4.4.1.3. Linking the Systems in the Workbench Application	330
4.4.2. Lay-Up Mapping in ACP (Pre)	330
4.4.3. Analysis of A Mapped Composite Model	334
4.5. Shear Dependent Materials in Composite Analysis	335
4.6. 3D Ply Workflow – Imported Plies	342
4.6.1. Inputs	342
4.6.2. Example of Use - HDF5 Composite CAE	344
4.7. ACP for Workbench LS-DYNA: Bird Strike	346
4.7.1. Workbench Workflow	347
4.7.2. Engineering Data – Material Model Definition	347
4.7.3. SpaceClaim – Geometry	349
4.7.4. Mechanical Model Setup	350
4.7.5. ACP - Material Assignment and Lay-Up	350
4.7.6. Setting Up the LS-DYNA Analysis System	351
4.7.7. Post-Processing in Workbench LS-DYNA:	352
4.8. Workflow with Equivalent Beam Models	353
4.8.1. Constant Composite Cross Section with a Straight Beam	354
4.8.2. Generic Composite Wind Blade	359
4.8.3. Conclusion	364
5. Guide for ACP Terminology	365
Bibliography	369

List of Figures

1.1. Oriented Selection Set Properties	4
1.2. Ansys Composite PrepPost GUI	10
1.3. Ansys Composite PrepPost Menu Options	10
1.4. File Menu for Workbench Integration	11
1.5. Stand-Alone File Menu	12
1.6. View Menu	12
1.7. Perspective Submenu	13
1.8. Show View	13
1.9. Tools Menu	14
1.10. Extract Materials From Composite CAE H5... Dialog	14
1.11. Winding Wizard with the Inputs on Top and the Description at the Bottom	16
1.12. Preferences Window	17
1.13. General ACP Preferences	18
1.14. Logger Preferences	18
1.15. Scene Preferences	19
1.16. Section Generation Preferences	20
1.17. Units Menu	20
1.18. Tree View	22
1.19. Locked Rosettes and the Update Status	22
1.20. Excel Link Dialog	24
1.21. Orientation Visualizations in the Toolbar	26
1.22. Visualization of the Element Normals	27
1.23. Visualization of the OSS Normal	27
1.24. Visualization of the OSS Reference Direction	28
1.25. Fiber Directions in the Toolbar	28
1.26. Visualization of the Fiber Direction	29
1.27. Visualization of the Transverse Ply Direction	29
1.28. Draping Directions in the Toolbar	30
1.29. Fiber Directions (Defined and Draped)	30
1.30. Traverse Directions (Defined and Draped)	31
1.31. Material 1 Direction and Draped Fiber Direction for a Material with a 45° Fabric Fiber Angle	31
1.32. Enclosed Box and Coordinate System	32
1.33. Distance Measure Tool	33
1.34. Properties from Right-Click Context Menu	43
1.35. Properties Menu: Setup	43
1.36. Sample Workflow of ACP – LS-DYNA within Workbench	45
1.37. Create an LS-DYNA Keyword (.k) File from the Workbench Model within Mechanical	46
1.38. Multiple Load Cases and Analyses	47
1.39. Two Analyses Share the Same ACP (Pre) Setup	48
1.40. Import Volume Mesh from Mechanical Model (E4 to C5)	49
1.41. Import Volume Mesh from Third Party Application	50
1.42. A Multi-System Analysis in Workbench	50
1.43. Write Input File	58
1.44. Import Ansys Model Using the Context Menu	59
2.1. Model Context Menu in Workbench Mode	62
2.2. Model Context Menu in Stand-Alone Mode	62
2.3. General Model Properties	64
2.4. Model Statistics	64
2.5. Solver Information (Solve.out)	67

2.6. Export Composite Definitions Window	67
2.7. Import Composite Definitions Window	67
2.8. Element-based vs. Node-based Piercing	69
2.9. Ply Extension and Element-wise Thicknesses of a Tapered Ply with Element-based (left) and Node-based (right) Thicknesses	69
2.10. Restriction for Node-based Thicknesses	70
2.11. Extrusion of a Tapered Ply without and with Node-based Thicknesses on the Left and Right, Respectively	70
2.12. Solid Model Extrusion of a Tapered Ply without and with Node-based Thicknesses	71
2.13. Cut-Off Selection Rule with Ply Tapering Based on Element-based and Node-based Thicknesses	71
2.14. Materials Class Context Menu in Stand Alone Mode	75
2.15. Example of Woven Material with a 45° Fabric Fiber Angle	79
2.16. Fabric Properties - General	85
2.17. Fabric Properties - Analysis	86
2.18. Fabric Properties - Solid Model Options	87
2.19. Fabric Properties - Draping	88
2.20. Stackup Properties - General	89
2.21. Stackup Sequence with Even Symmetry	90
2.22. Stackup Sequence with Odd Symmetry	91
2.23. Lay-Up Information and Polar Properties	92
2.24. CLT Analysis - Laminate Engineering Constants	93
2.25. Sub Laminate Properties - General Tab	94
2.26. Element Set Selection	95
2.27. Element Set Context Menu	96
2.28. Edge Set Definition	97
2.29. Example of three Cut-Off geometries	98
2.30. CAD Geometry Assembly and Virtual Geometries in the Tree View	98
2.31. Example of Multiple Virtual Geometries	100
2.32. Property Dialog CAD Geometry	100
2.33. Project Schematic with a CAD Geometry Import in ACP	101
2.34. Create Virtual Geometry Directly from CAD Geometry Part	102
2.35. Create Virtual Geometry Through CAD Geometry Parts in Tree	102
2.36. Create Virtual Geometry Through Face Selection in the Scene	103
2.37. Rosette Properties Dialog	104
2.38. Oriented Selection Set with a Radial Rosette	105
2.39. Oriented Selection Set with a Cylindrical Rosette	105
2.40. Oriented Selection Set with a Spherical Rosette	106
2.41. Edge-Wise Rosette	106
2.42. Schematic of 1-D Look-Up Table Function	112
2.43. Look-Up Table Values	113
2.44. Interpolated Values with Weighted Nearest Neighbor, Nearest Neighbor, and Linear Multivariate (From Left to Right)	113
2.45. Look-Up Table Interpolation Parameters	114
2.46. Setting the Dimension in the Column Properties Dialog	115
2.47. Selection Rules Context Menu	115
2.48. Definition of a Parallel Selection Rule	116
2.49. Example of a Parallel Selection Rule	117
2.50. Example of a tube rule with an outer and inner radius	118
2.51. Tube Selection Rule Properties	119
2.52. Edge with a long extension at the head of the edge and a short one at the tail	120
2.53. Cut-Off Selection Rule Properties	121

2.54. Trailing Edge with Cut-Off Plies (Ply Tapering Activated)	122
2.55. Section of the Cut-Off Geometry	122
2.56. Core Thickness Without Ply Tapering (Left) and With Ply Tapering (Right)	123
2.57. Taper Cut-Off Selection Rule Definition	124
2.58. Section with The Production Ply Option	124
2.59. Section with the Analysis Ply Option	125
2.60. Section with the Analysis Ply with Tapering Option	125
2.61. Example Geometrical Selection Rule	126
2.62. Geometrical Selection Rule Properties	126
2.63. Capture Tolerances	128
2.64. Look-Up Table Defines the Offset to Edge Set at a Given Length	129
2.65. Offset Correction	130
2.66. Offset Mapping Along a Direction Vector	130
2.67. Boolean Selection Rule	131
2.68. Boolean Operation Types	131
2.69. Orientation Point Definition	132
2.70. Definition	133
2.71. Reference Direction of a Bonding Laminate Defined by Two Rosettes and a Minimum Angle Selection Method	135
2.72. Reference Directions Along an Edge and Perpendicular to an Edge	136
2.73. Axial Reference Direction	137
2.74. Selection Rules	137
2.75. Draping	138
2.76. Object Tree of a Lay-Up Definition	140
2.77. Context Menu of Modeling Groups	140
2.78. General Information	142
2.79. Internal Draping Definition	144
2.80. Draping with Tabular Values Definition	145
2.81. Thickness Definition	146
2.82. Thickness Definition Options	147
2.83. Core Geometry	147
2.84. Resulting Section Cut	148
2.85. Edge Tapering	149
2.86. Taper Edge Example	149
2.87. Right-Click Modeling Ply Menu	150
2.88. Interface Layer Properties - General	152
2.89. Interface Layer Properties - Open Area	152
2.90. Drop-Off Elements and a Butt Joint Between Two Cores	153
2.91. Production Ply Context Menu	156
2.92. Analysis Ply Context Menu	156
2.93. CSV Import with Update Options	157
2.94. Export Ply Geometry Window	159
2.95. General Properties Options	162
2.96. Draping Properties Options	163
2.97. Thickness Properties Options	163
2.98. Imported Production Ply Dialog	164
2.99. Imported Analysis Ply	165
2.100. Field Definitions Context Menu	166
2.101. Field Definition Context Menu	167
2.102. Field Definition Object Properties	168
2.103. Sampling Point Properties (General Tab)	169

2.104. Sampling Point Properties (Analysis Tab Containing Lay-up Sequence and Polar Properties)	170
2.105. General Section Cut Properties	171
2.106. Wire Frame Options	172
2.107. Surface Options	172
2.108. Section Cut Crossing an Element Corner	173
2.109. Element Normals	174
2.110. Surface Normal vs. Surface Sweep Based Extrusion	174
2.111. Ply-Wise Angles on the Surface Section Cut	175
2.112. Supported Lay-up for T-Joints	175
2.113. Export Surface Section Cut Options	175
2.114. Elastic Properties after Running Analysis of the Sectional Properties (via Run Analysis Button)	176
2.115. Section Cut Mesh and Results	177
2.116. 3D Representation of a Beam Slice (with Respect to the Global Coordinate System)	178
2.117. Sensor Properties	182
2.118. Solid Model Folder with a Standard Solid Model and an Imported Solid Model	183
2.119. Solid Model Feature in the Tree View	184
2.120. Solid Model Properties - General	185
2.121. Illustration of Solid Model Extrusion Methods	187
2.122. Offset Direction - Schema	187
2.123. Offset Direction - Example	187
2.124. Solid Model Properties - Drop-Offs	189
2.125. Disable Drop-Offs	190
2.126. Connect Butt-Jointed Plies	190
2.127. Solid Model Properties - Export	191
2.128. Write Degenerated Elements	192
2.129. Quadratic Tetrahedral Element on Top of a Hexahedral Element	192
2.130. Transferred Element Sets in Mechanical	193
2.131. Properties of the ACP-Pre Setup Cell in the Project Schematic	194
2.132. Extrusion with and without an Edge Set Guide	195
2.133. Extrusion Guide Properties	196
2.134. Reordering Extrusion Guides	197
2.135. Mesh Morphing Diagram	198
2.136. Example of a Direction-type Extrusion Guide with Different Mesh Morphing Radii	199
2.137. Example of a Geometry-type Extrusion Guide with Different Mesh Morphing Depths.	200
2.138. Extrusion without Snap Operation	201
2.139. Extrusion with Snap-To Geometry at the Top (Shell Geometry also Displayed)	202
2.140. Extrusion with Snap-To Geometry at the Top and Bottom (Shell Geometry also Displayed)	202
2.141. Extruded Solid Model	203
2.142. Cut-Off Geometries Shown Alongside Extruded Solid Model	203
2.143. Solid Model with Cut-Off Features	203
2.144. Cut-Off Geometry Normal Direction	204
2.145. Example of three Cut-Off geometries	205
2.146. A Degenerated Hexahedral Element (left) is Decomposed into Several Tetrahedral Elements (right) ...	205
2.147. Solid Model with Highlighted Drop-Off elements	207
2.148. Tree Object of the Imported Solid Model Feature	208
2.149. Transfer of Mesh Components from an External Mesh via External Model, Mechanical to ACP Pre	212
2.150. Element Normals of the Filler Elements Computed from Two Rosettes.	217
2.151. Thickness Plot	226
2.152. Angle Plot	227
2.153. Draping Mesh Plot Properties	228
2.154. Draping Mesh	228

2.155. Draping Plot for a Hemisphere	229
2.156. Flatwrap Surface of the Ply	229
2.157. Look-Up Table Plot General Properties Tab	230
2.158. Look-Up Table Plot of a 1-D Scalar Quantity with Supporting Points Shown as Circles	231
2.159. Lay-Up Mapping General Properties Tab	232
2.160. Deviation of the Normal Direction between Shell Elements and Layered Solid Elements	232
2.161. Scene Properties	233
2.162. Connection of ACP and Workbench Parameter Interface	241
2.163. Parameter Properties	242
2.164. Material Database	245
2.165. Export and Import Options in Model Context Menu	246
2.166. HDF5 Composite CAE File Export Settings	247
2.167. 3D Representation of a Lay-Up with Offset Ply Surfaces	247
2.168. The External Model Component in Workbench	248
2.169. HDF5 Composite CAE File Import Settings	250
2.170. Schematic of Tolerance Settings for a Single Element	252
2.171. SHELL181 Keyopts	253
2.172. SHELL281 Keyopts	254
2.173. SOLID185 Keyopts	254
2.174. SOLID186 Keyopts	254
2.175. Configuration Overview	255
2.176. Configuration Overview	256
2.177. A Four Ply Mechanical APDL Lay-up Where a Ply Crosses the Reference Surface is Converted to a Five Ply ACP Lay-up	257
2.178. ModelingGroup Tabular Format in Excel	257
2.179. Look-Up Table Tabular Format in Excel	258
3.1. T-Joint Lay-Up	262
3.2. OSS for the Base Plate	262
3.3. OSS for the Stringer	263
3.4. OSS for Bonding Plies	263
3.5. Reference Direction	264
3.6. Laminate of the Base Plate	265
3.7. Laminate of the Base Plate and Stringer	265
3.8. First Bonding Laminate	266
3.9. Second Bonding Laminate	266
3.10. Cover Plies	267
3.11. Tube Selection Rule	268
3.12. Rules Tab of the Modeling Ply Property Dialog	268
3.13. Resulting Local Reinforcements	269
3.14. Simple Edge Tapering	270
3.15. Tapered Edge	270
3.16. Tapering in Ply Definition	271
3.17. Thickness Distribution After Core Tapering	271
3.18. Superposition of Modeling Plies with Identical Taper Angles. Schematic (Middle) and Section View Illustration (Right)	272
3.19. Thickness Distribution of a Laminate with a Cutoff Selection Rule	273
3.20. Template Selection Rule Definition	273
3.21. Imported Core Geometry	274
3.22. Modeling Ply Thickness Definition	275
3.23. Section with Variable Core Thickness	275
3.24. Table Definition	276

3.25. Thickness Definition Through Tabular Values	276
3.26. Section Cut and Thickness Contour Plot	277
3.27. Imported Cut-Off Geometry	278
3.28. Resulting Thickness Distribution (Ply Tapering Activated)	278
3.29. Flatwrap (Boundary)	279
3.30. Draping Mesh with Shear Energy	280
3.31. Draping Definition in OSS	281
3.32. Tabular Values Definition of Draping	282
3.33. Fiber and Draped Fiber Directions	283
3.34. Analyzing a Solid Model Alongside a Shell Model	286
3.35. Solid Model Assembly Workflow	287
3.36. Conversion of the Named Selections in the Solid Model Workflow	288
3.37. A quadrilateral interface element surrounded by a brick element and two tetrahedral elements created when the Drop-Off is split	290
3.38. T-Joint Section Cut	291
3.39. Class40 Section Cut	291
3.40. Insert Deformation Object under the Solution Group	292
3.41. Modify the Display Time and/or Deformation Scale of the Result Object	292
3.42. Insert a Composite Failure Tool under the Solution	293
3.43. Configure the Failure Criteria definition in the Composite Failure Tool group	293
3.44. Modify the Displayed Information (Failure Mode, Critical Layer)	294
3.45. Type of Failure Plot	294
3.46. IRF Value, Text Plot for Each Element, and Zoom on Area (Tutorial 1)	295
3.47. Active Ply-Wise Scoping	296
3.48. Select Ply Field	296
3.49. Select a Ply in the Imported Plies Group	297
3.50. Evaluate the Result of Ply-Wise Scoping (Tutorial 1)	297
3.51. Promote the Failure Criteria Definition of the Composite Failure Tool	298
3.52. Modify the Promoted Composite Failure Criteria Object when Necessary	299
3.53. Insert a Composite Sampling Point Tool Object	299
3.54. Select Failure Criteria under Sampling Point Tool Group	300
3.55. Choose Sampling Point on Geometry and Apply Selection	300
3.56. Review the Selected Point	300
3.57. Evaluate the Sampling Point's Results	301
3.58. Field Definition Properties to Set Up a Degradation Factor Field	305
4.1. ACP Components	309
4.2. Engineering Data Sources	309
4.3. Outline of Composite Materials	310
4.4. Material Properties for ACP	311
4.5. Context Menu of ACP (Pre) Setup	313
4.6. Connecting a Static Structural Analysis to ACP (Pre) using a Drag and Drop Operation	314
4.7. Conversion of the Named Selections in the Solid Model Workflow	316
4.8. Workbench Software Workflow for Composite Solid Modeling with Mechanical Application	317
4.9. Workbench Software Workflow for Composite Solid Modeling with Mechanical APDL Application	317
4.10. Analysis of a Composite Doubly-Curved Specimen and Metal Grips Modeled with Mechanical Application	318
4.11. One Layered Solid Specimen and Two Metal Grips in Mechanical Model	318
4.12. Analysis of Composite Plate and T-joint Modeled with the Mechanical APDL Application	319
4.13. Add Reference File	319
4.14. List of Used Files and Their Order in Mechanical APDL	319
4.15. Race Car Setup in the Workbench Application	321

4.16. Predefined and User-Defined Field Variables in Engineering Data	322
4.17. Assigning a Field Variable to Material Property	322
4.18. Populating the Tabular Material using the CSV Interface	323
4.19. Setting Interpolation Options	323
4.20. Draping Results	324
4.21. Distribution of the Curing Degree (Scalar Look-Up Table Plot)	325
4.22. Activating a Look-Up Table to Define Curing per Modeling Ply (Layer-Wise)	325
4.23. Using External Data to Define Temperature Field	326
4.24. Inverse Reserve Factor (Constant Material Data on the Left; Variable Material Properties on the Right)	326
4.25. Geometry and Lay-Up of the Composite Spring	327
4.26. Complete Project Schematic in the Workbench Application	328
4.27. Mechanical Application Model F4 with the Bodies Roving and Tube	329
4.28. Detail View of the Final Solid Mesh with Hex Elements only in the Outer Body	330
4.29. Mesh Features and Solid Mesh with the Inflation Layers and Roving Cross Section	330
4.30. Imported Solid Model Properties Dialog	331
4.31. Figure: Lay-up Mapping Definition of the Mesh Component Tube	332
4.32. The Filler Options for the Roving	332
4.33. Filler Elements and Fiber Directions	333
4.34. <i>Using the Filler Option for the Roving</i>	334
4.35. Ply-wise Failure Analysis	335
4.36. Project Setup in the Workbench Application	336
4.37. Woven RVE defined in Material Designer Application	336
4.38. Materials in the Engineering Data Component of the ACP system	337
4.39. Shear Dependent Fabric Fiber Angle	337
4.40. Ply Definition	338
4.41. Fiber (Light Green), Transverse (Dark Green) and Material 1 (Red) Directions	338
4.42. Draping Definition	339
4.43. Draping Mesh in the ACP Application	340
4.44. Shear Angle Plot	340
4.45. Draped Fiber Direction (Light Blue), Draped Transverse Direction (Blue) and Material 1 Direction (Red)	341
4.46. Shear-Dependent Young's Modulus	341
4.47. Deformation Plot (variable material on left, constant material on right)	342
4.48. 3D Ply Workflow (Courtesy of 9T Labs)	343
4.49. HDF5 Composite CAE Imported as 3D Plies (Imported Modeling Plies)	344
4.50. 3D Printing with Endless Fiber Reinforcement and Final Part (Courtesy of 9T Labs)	344
4.51. Simulation of a 3D Printed Composite (Courtesy of 9T Labs)	345
4.52. Distribution of the Inverse Reserve Factors in the Mapped Composite Solid Model	346
4.53. The Drag-and-Drop Workflow Showing the Transfer of ACP Composite Models to a Workbench LS-DYNA Analysis System	347
4.54. Setting up an Automatic Conversion of LS-DYNA Material Models	348
4.55. Material Definition for LS-DYNA in Engineering Data	349
4.56. Geometry Preparation in SpaceClaim	349
4.57. Mechanical Model - Assigning Part Properties to the Bird Body	350
4.58. Defining Materials in ACP	351
4.59. Composite Lay-Up Modeling in ACP	351
4.60. : Setting Up the Analysis	352
4.61. Accessing Input Files and Results Files	353
4.62. Workflow of a Model Analysis with an Equivalent Beam Model	354
4.63. Cross Section and Layup of the Box	355

4.64. Computation Result of the Equivalent Beam Properties	356
4.65. Mesh of the Cross Section and its Principal Properties	356
4.66. APDL Snippet to Apply the Beam Properties	357
4.67. Comparison of Mode Shapes for the First and Fifth Frequencies	358
4.68. Geometry of the Generic Wind Turbine Blade	360
4.69. Wind Turbine Blade with the 101 Cross Sections	361
4.70. Two Meshes of Different Cross Sections and the Corresponding Shear, Elastic, and Center of Gravity	361
4.71. APDL Snippet with the Generated Output from ACP	362

List of Tables

- 1.1. Predefined Unit Systems 20
- 2.1. Key Differences Between a Modeling Ply and Imported Modeling Ply 160
- 4.1. Material Properties 355
- 4.2. Comparison of the 3D Solid Model and Equivalent Beam Model Results 357
- 4.3. Material Properties 360
- 4.4. Comparison of the 3D Shell Model and Equivalent Beam Model Results 362

Chapter 1: Getting Started

The following sections describe how to begin using Ansys Composite PrepPost (ACP):

- 1.1. Overview
- 1.2. The Ansys Product Improvement Program
- 1.3. Graphical User Interface
- 1.4. Implementation in Workbench
- 1.5. Migrating ACP Projects from Previous Versions
- 1.6. The ACP Python Scripting User Interface
- 1.7. Stand Alone Operation
- 1.8. Tutorials and Examples

1.1. Overview

The following sections provide an overview of Ansys Composite PrepPost (ACP).

- 1.1.1. Introduction
- 1.1.2. Supported Platforms and Functional Add-ons
- 1.1.3. Known Limitations
- 1.1.4. First Steps

1.1.1. Introduction

Composite materials are created by combining two or more layered materials, each with different properties. These materials have become a standard for products that are both light and strong. Composites provide enough flexibility so products with complex shapes, such as boat hulls and surfboards, can be easily manufactured.

Engineering layered composites involves complex definitions that include numerous layers, materials, thicknesses and orientations. The engineering challenge is to predict how well the finished product will perform under real-world working conditions. This involves considering stresses and deformations as well as a range of failure criteria. Ansys Composite PrepPost provides all the necessary functionalities for preprocessing layered composite structures, while Mechanical provides postprocessing capabilities for composite analyses.

ACP Workflows

Ansys Composite PrepPost (ACP) is an add-in to Ansys Workbench and is integrated with the standard analysis features. As a result, the entire workflow for a composite structure can be completed from design to final production information.

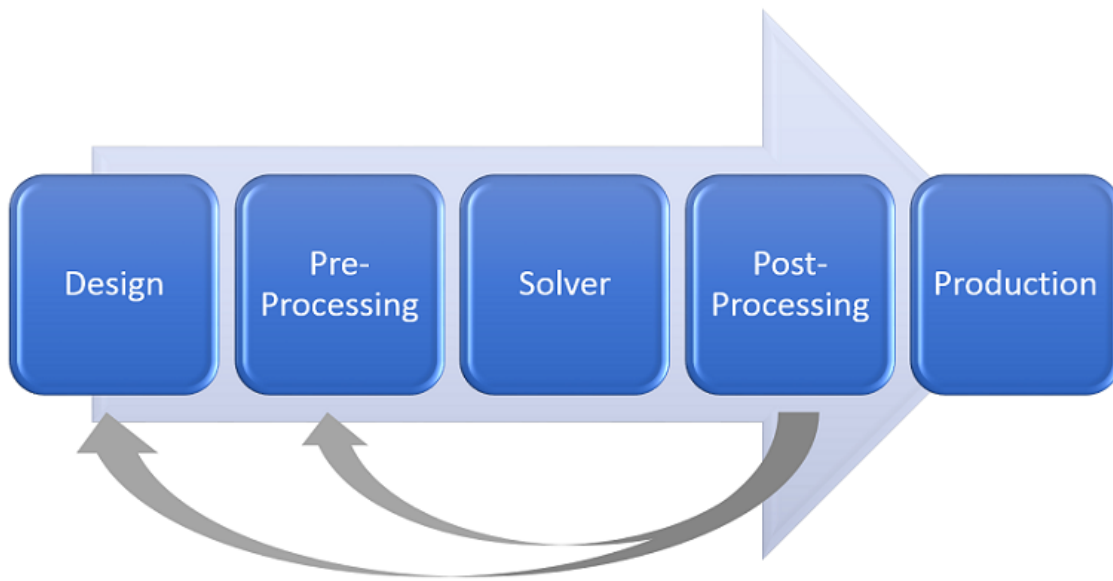

The geometry of the tooling surfaces of a composite structure is the basis for analysis and production. Based on this geometry and a FE mesh, the boundary conditions and composite definitions are applied to the structure in the preprocessing stage. After a completed solution, the post-processing is used to evaluate the performance of the design and laminate. In the case of an insufficient design or material failure, the geometry or laminate has to be modified and the evaluation is repeated.

ACP has only a preprocessing mode, in which all composite definitions can be created and mapped to the geometry (FE mesh). Then, these composite definitions are transferred to the FE model and the solver input file. After the composite analysis is completed and the result file(s) are imported, postprocessing results (failure, safety, strains, and stresses) can be evaluated and visualized in Mechanical.

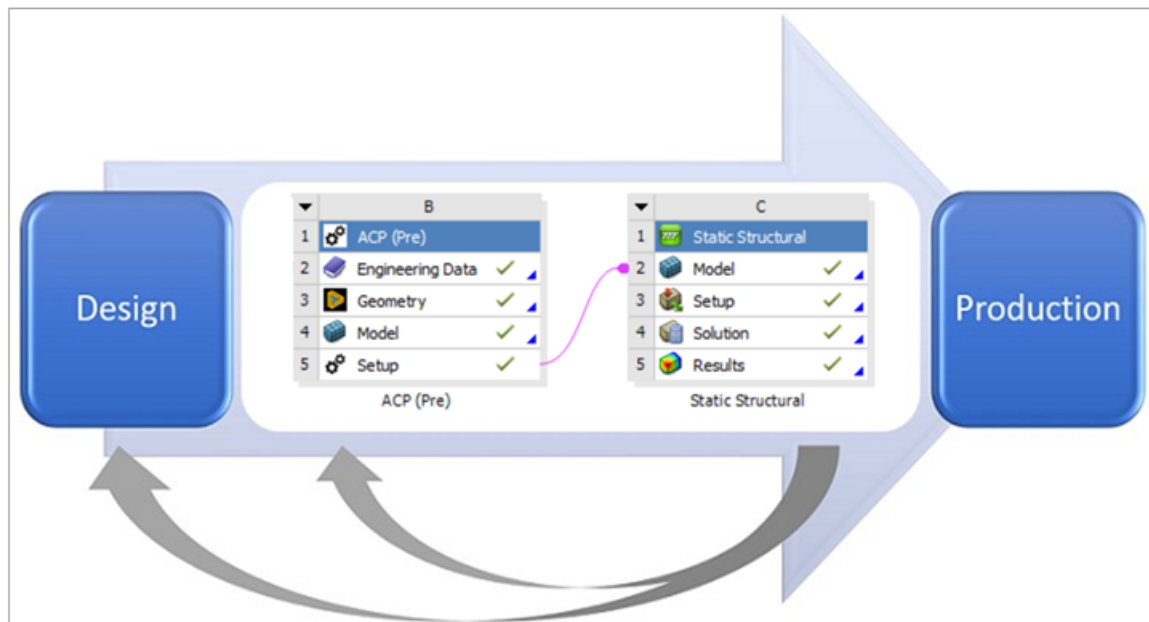

1.1.2. Supported Platforms and Functional Add-ons

Supported Platforms

ACP is supported on both Windows and Linux systems. For information about specific operating system versions and distributions, see the [Platform Support section of the Ansys Website](#).

ACP has additional library dependencies in Red Hat Enterprise Linux, for information on how to install those libraries, see [Post-Installation Procedures for Other Products in the Ansys, Inc. Linux Installation Guide](#).

Functional Add-ons

ACP provides functional add-ons for problem-specific functionality. These add-ons are not considered appropriate for general use and should be used with caution. No standard documentation is provided for these features, but additional information is available on request. For more information, contact info-switzerland@ansys.com.

For information on how to activate these add-ons, see [Add Ons \(p. 17\)](#).

1.1.3. Known Limitations

ACP has the following known limitations. Note that feature-specific limitations are often documented with the corresponding feature description throughout the ACP user's guide.

Support for Unicode

Unicode is supported in ACP except for these features:

- **Names in CDB Export:** Unicode (non-ASCII) characters in an ACP model are converted to underscores when the model is exported as a CDB (coded database) file. This can cause two different names to become the same after the conversion.

ACP issues a warning when a duplicate name is exported. This check for all names that are considered equivalent in Mechanical APDL is stricter than the check for the conversion from Unicode to ASCII.

- **File Paths in ACP to Mechanical APDL Workflows:** In an ACP to Mechanical APDL workflow within Workbench, the file path of the Workbench project must not contain Unicode (non-ASCII) characters.
- **Laminate Plot Labels:** The labels in the laminate plots of stackups, sublaminates, and sampling points support only a limited set of Unicode.
- **User-Defined Plot Text:** The user-defined text in user-defined plots supports only a limited set of Unicode.
- **Ply Books in PDF Format:** When generating a Ply Book in PDF format, you must adjust the font in case unsupported characters are used.

Composite Failure Tool for Migrated ACP Projects

The Composite Failure Tool in Mechanical can only be used in migrated projects once the **ACP (Pre) Setup** Workbench cell has been updated.

Coordinate System Naming for Migrated ACP Projects

In Version 2019 R2, naming is maintained when coordinate systems defined in Workbench are transferred to ACP as Rosettes. (See [Rosettes \(p. 103\)](#).) When migrating projects from previous versions, the Oriented Selection Set Properties may lose the Rosette link due to the renaming. This will require lay-up definitions to be updated manually as shown in [Figure 1.1: Oriented Selection Set Properties \(p. 4\)](#). For more information on migrating projects from previous versions, see [Migrating ACP Projects from Previous Versions \(p. 53\)](#).

Figure 1.1: Oriented Selection Set Properties

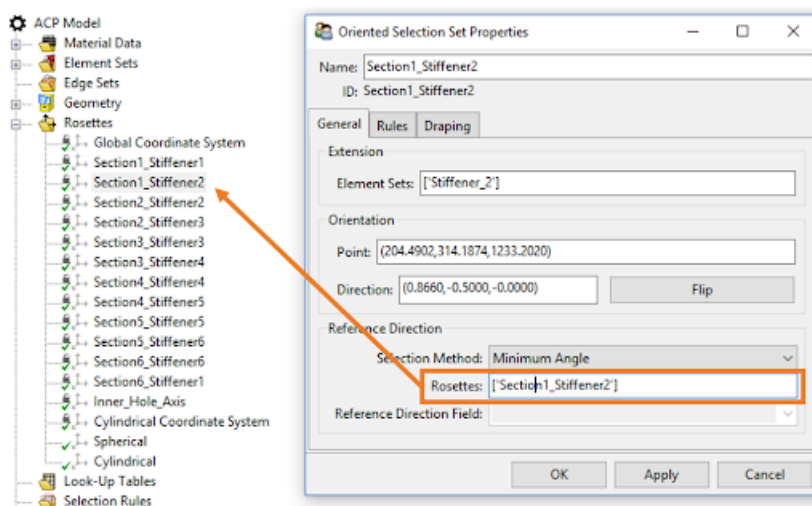

Export System(s) and Import to Workbench

The Export System(s) and Import of Workbench projects are not supported for ACP Systems. With this current limitation, the imported ACP systems cannot be updated correctly after import.

Parameters

In ACP, Parameters, and how they are handled by the Parameter Manager, have certain limitations. See the [Parameters \(p. 241\)](#) section for additional information.

Options for Objects with the Same Name

The application allows you to create objects with the same name. However, there are certain property specification and graphical selection limitations for this scenario. Based on the object type, you may not be able to define the properties to include objects with the same name. For example, you cannot define Sub Laminates using a Fabric and Stackup that have the same name.

1.1.4. First Steps

The best way to get to know the features of ACP is to attempt one of the tutorials. There are two tutorials that explain step-by-step how to define and analyze basic composite structures. The tutorials both start off with existing Workbench projects. These sample projects and more information can be found in the [ACP Tutorials](#). Knowledge of Ansys Workbench is a prerequisite.

For information on how to build a composite model from new, see [Analysis of a Composite Shell Model \(p. 307\)](#).

There are many ways to implement ACP in Workbench. The workflow for modeling composite solid element models is described in [Analysis of a Composite Shell Model \(p. 307\)](#). Other examples are shown in [Implementation in Workbench \(p. 38\)](#).

[Composite Modeling Techniques \(p. 261\)](#) offers an insight into modeling approaches for common composite problems.

Explanations and specific information of the ACP features can be found in [Features \(p. 61\)](#).

Background information on the underlying theory used in ACP is available in [Composites Theory Reference in the Composites Theory Reference](#). This is especially of interest for the failure criteria.

1.2. The Ansys Product Improvement Program

This product is covered by the Ansys Product Improvement Program, which enables Ansys, Inc., to collect and analyze *anonymous* usage data reported by our software without affecting your work or product performance. Analyzing product usage data helps us to understand customer usage trends and patterns, interests, and quality or performance issues. The data enable us to develop or enhance product features that better address your needs.

How to Participate

The program is voluntary. To participate, select **Yes** when the Product Improvement Program dialog appears. Only then will collection of data for this product begin.

How the Program Works

After you agree to participate, the product collects anonymous usage data during each session. When you end the session, the collected data is sent to a secure server accessible only to authorized Ansys employees. After Ansys receives the data, various statistical measures such as distributions, counts, means, medians, modes, etc., are used to understand and analyze the data.

Data We Collect

The data we collect under the Ansys Product Improvement Program are limited. The types and amounts of collected data vary from product to product. Typically, the data fall into the categories listed here:

Hardware: Information about the hardware on which the product is running, such as the:

- brand and type of CPU

- number of processors available
- amount of memory available
- brand and type of graphics card

System: Configuration information about the system the product is running on, such as the:

- operating system and version
- country code
- time zone
- language used
- values of environment variables used by the product

Session: Characteristics of the session, such as the:

- interactive or batch setting
- time duration
- total CPU time used
- product license and license settings being used
- product version and build identifiers
- command line options used
- number of processors used
- amount of memory used
- errors and warnings issued

Session Actions: Counts of certain user actions during a session, such as the number of:

- project saves
- restarts
- meshing, solving, postprocessing, etc., actions
- times the Help system is used
- times wizards are used
- toolbar selections

Model: Statistics of the model used in the simulation, such as the:

- number and types of entities used, such as nodes, elements, cells, surfaces, primitives, etc.

- number of material types, loading types, boundary conditions, species, etc.
- number and types of coordinate systems used
- system of units used
- dimensionality (1-D, 2-D, 3-D)

Analysis: Characteristics of the analysis, such as the:

- physics types used
- linear and nonlinear behaviors
- time and frequency domains (static, steady-state, transient, modal, harmonic, etc.)
- analysis options used

Solution: Characteristics of the solution performed, including:

- the choice of solvers and solver options
- the solution controls used, such as convergence criteria, precision settings, and tuning options
- solver statistics such as the number of equations, number of load steps, number of design points, etc.

Specialty: Special options or features used, such as:

- user-provided plug-ins and routines
- coupling of analyses with other Ansys products

Data We Do Not Collect

The Product Improvement Program does *not* collect any information that can identify you personally, your company, or your intellectual property. This includes, but is not limited to:

- names, addresses, or usernames
- file names, part names, or other user-supplied labels
- geometry- or design-specific inputs, such as coordinate values or locations, thicknesses, or other dimensional values
- actual values of material properties, loadings, or any other real-valued user-supplied data

In addition to collecting only anonymous data, we make no record of where we collect data from. We therefore cannot associate collected data with any specific customer, company, or location.

Opting Out of the Program

You may *stop* your participation in the program any time you wish. To do so, select **Ansys Product Improvement Program** from the Help menu. A dialog appears and asks if you want to continue participating in the program. Select **No** and then click **OK**. Data will no longer be collected or sent.

The Ansys, Inc., Privacy Policy

All Ansys products are covered by the Ansys, Inc., [Privacy Policy](#).

Frequently Asked Questions

1. *Am I required to participate in this program?*

No, your participation is voluntary. We encourage you to participate, however, as it helps us create products that will better meet your future needs.

2. *Am I automatically enrolled in this program?*

No. You are not enrolled unless you explicitly agree to participate.

3. *Does participating in this program put my intellectual property at risk of being collected or discovered by Ansys?*

No. We do not collect any project-specific, company-specific, or model-specific information.

4. *Can I stop participating even after I agree to participate?*

Yes, you can stop participating at any time. To do so, select **Ansys Product Improvement Program** from the Help menu. A dialog appears and asks if you want to continue participating in the program. Select **No** and then click **OK**. Data will no longer be collected or sent.

5. *Will participation in the program slow the performance of the product?*

No, the data collection does not affect the product performance in any significant way. The amount of data collected is very small.

6. *How frequently is data collected and sent to Ansys servers?*

The data is collected during each use session of the product. The collected data is sent to a secure server once per session, when you exit the product.

7. *Is this program available in all Ansys products?*

Not at this time, although we are adding it to more of our products at each release. The program is available in a product only if this *Ansys Product Improvement Program* description appears in the product documentation, as it does here for this product.

8. *If I enroll in the program for this product, am I automatically enrolled in the program for the other Ansys products I use on the same machine?*

Yes. Your enrollment choice applies to all Ansys products you use on the same machine. Similarly, if you end your enrollment in the program for one product, you end your enrollment for all Ansys products on that machine.

9. *How is enrollment in the Product Improvement Program determined if I use Ansys products in a cluster?*

In a cluster configuration, the Product Improvement Program enrollment is determined by the host machine setting.

10. *Can I easily opt out of the Product Improvement Program for all clients in my network installation?*

Yes. Perform the following steps on the file server:

- a. Navigate to the installation directory: [Drive:]\v251\commonfiles\globalsettings
- b. Open the file **ANSYSProductImprovementProgram.txt**.
- c. Change the value from "on" to "off" and save the file.

Additional Notes specific to ACP

If you run ACP in standalone mode, you can opt out or in under **Tools > Preferences > ACP > Ansys Product Improvement Program**.

1.3. Graphical User Interface

The user interface is split into the following parts:

- 1.3.1. Menus
- 1.3.2. Tree View
- 1.3.3. Scene
- 1.3.4. Toolbar
- 1.3.5. View Panes
- 1.3.6. Keyboard Shortcuts

The interface also contains [View Panes \(p. 34\)](#) that show how individual elements within the ACP interface can be rearranged.

Figure 1.2: Ansys Composite PrepPost GUI

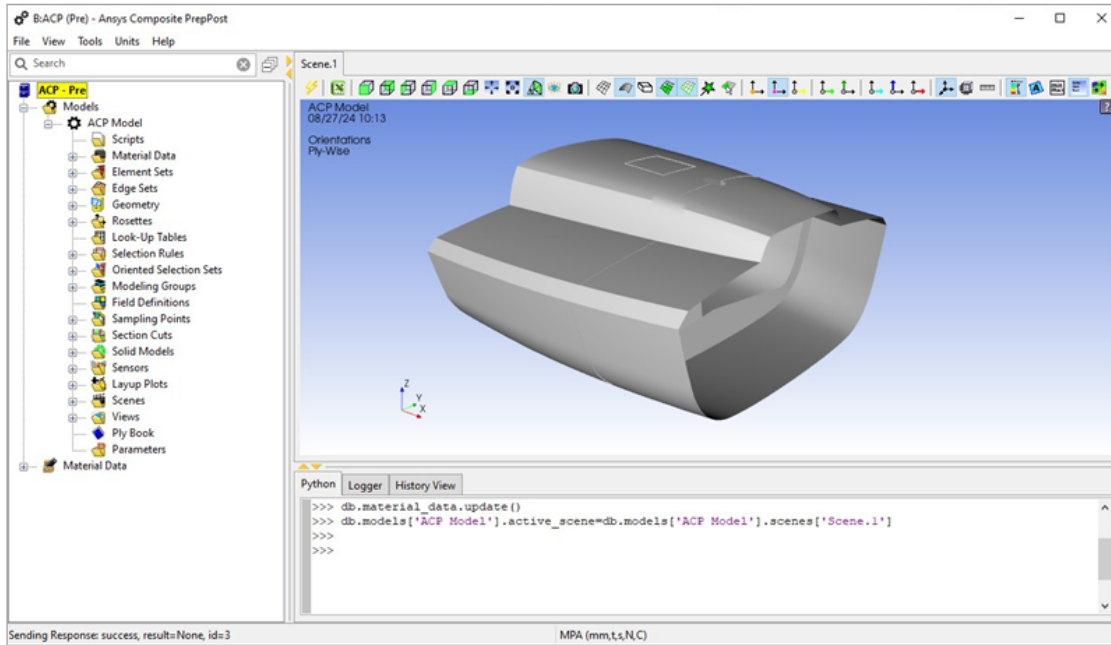

1.3.1. Menus

ACP (Pre) provides the following menu options:

- 1.3.1.1. File
- 1.3.1.2. View
- 1.3.1.3. Tools

Figure 1.3: Ansys Composite PrepPost Menu Options

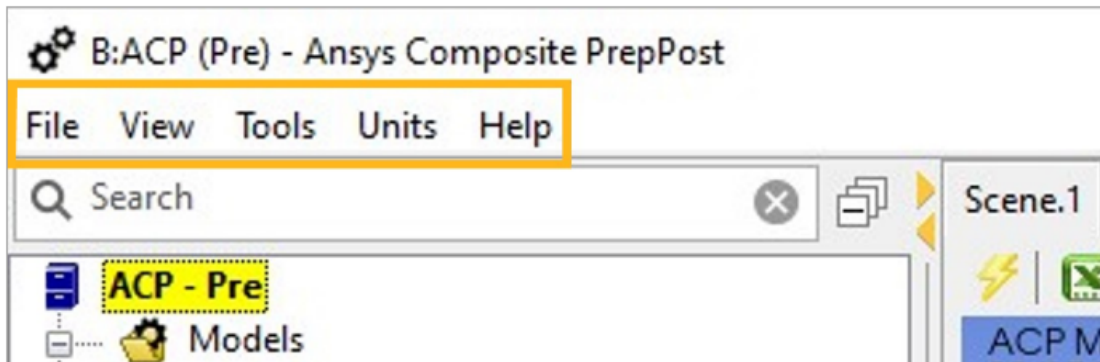

1.3.1.1. File

The **File** menu differs between Workbench and Stand Alone mode.

- 1.3.1.1.1. Workbench
- 1.3.1.1.2. Stand Alone

1.3.1.1.1. Workbench

When you launch ACP (Pre) from Workbench, the **File** menu contains the following options:

Save Project: If the project was not already saved, specify the project name and location. Saves the entire Workbench project.

Refresh All Data: Reloads the model in ACP. If the model is not up-to-date in the Workbench schematic, changes on the model (mesh, Named Selections) are not transferred to ACP. If you have made changes to the model, close ACP and update the model in Workbench.

Run Script: Select a Python script to execute.

Exit: Exit from Ansys Composite PrepPost. Any newly defined ACP features are not deleted.

Figure 1.4: File Menu for Workbench Integration

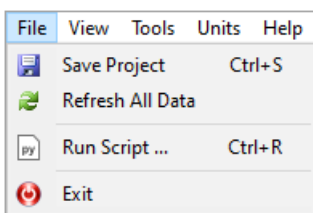

1.3.1.1.2. Stand Alone

When you open the application in stand-alone mode (via the Start menu), the **File** menu contains the following options:

Open: Open an existing database.

Save: Save the active database.

Save As: Save the active database, select location and file name.

Save All: Save all open databases.

Close: Close the active database.

Close All: Close all open databases.

Import Model: Import an Ansys model.

Run Script: Select a Python script to execute.

Exit: Exit from Ansys Composite PrepPost. Any newly defined ACP Features are not deleted.

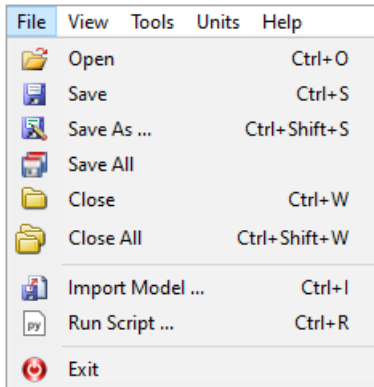
Figure 1.5: Stand-Alone File Menu

1.3.1.2. View

The layout of the GUI is managed through the **View** menu.

1.3.1.2.1. Perspectives

1.3.1.2.2. View Manager

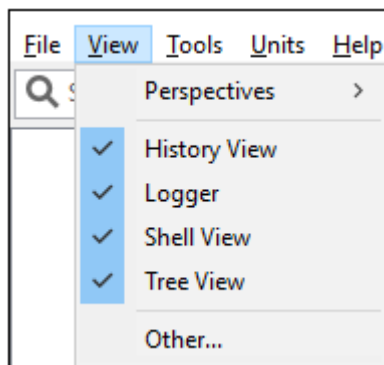
Figure 1.6: View Menu

1.3.1.2.1. Perspectives

The **Perspectives** submenu allows you to manage different interface layouts:

Perspective: Activate a named Perspective. Available perspectives appear in a list in the drop-down menu.

New Perspective: Create a new Perspective.

Save Perspective As: Save the current interface layout into a new Perspective.

Rename Perspective: Modify the name of the active Perspective.

Delete Perspective: Delete the active Perspective.

Reset Perspective: Reset the active Perspective to an empty Perspective.

Reset All Perspectives: Reset all defined Perspectives.

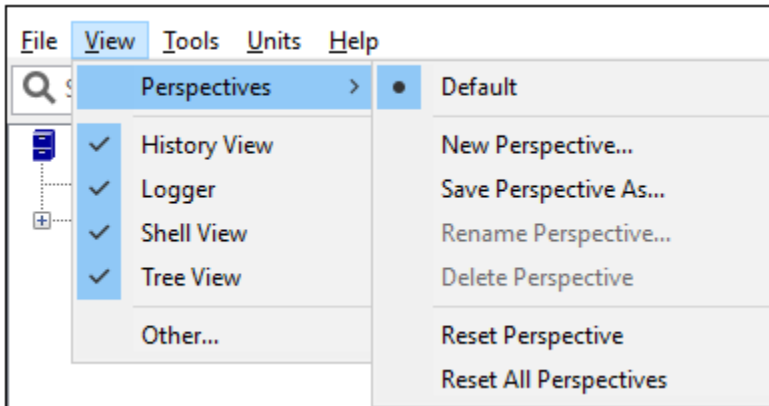
Figure 1.7: Perspective Submenu

1.3.1.2.2. View Manager

Interface elements can be added or removed from a Perspective by clicking **Other...** to bring up the **View Manager**. To activate a View, select it in the **View Manager** and click **OK**. The selected View appears in the **View** menu for the selected perspective. Views present in the Perspective can be activated or deactivated through the **View** menu.

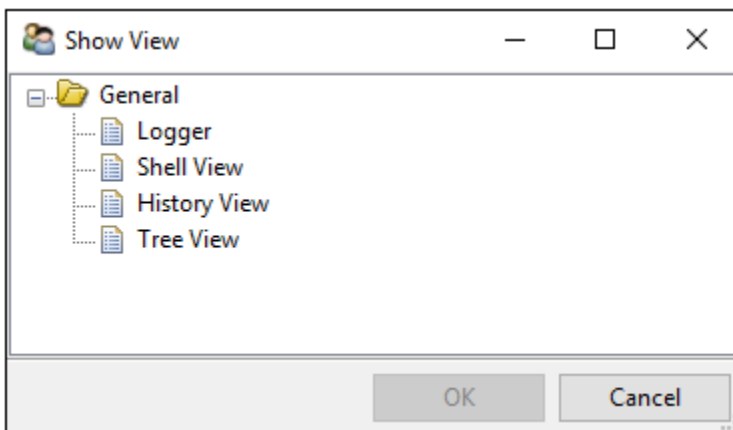
Figure 1.8: Show View

1.3.1.3. Tools

You will find the following options in the **Tools** menu:

- 1.3.1.3.1. Extract Materials From Composite CAE H5...
- 1.3.1.3.2. Winding Wizard
- 1.3.1.3.3. Migration Helper
- 1.3.1.3.4. Preferences

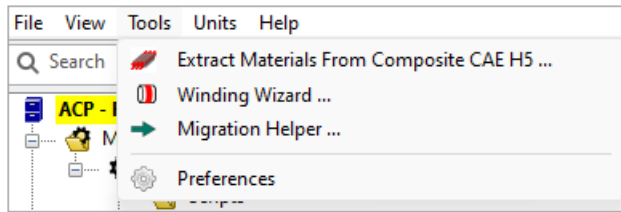
Figure 1.9: Tools Menu

1.3.1.3.1. Extract Materials From Composite CAE H5...

This option allows you to extract material data from an [HDF5 Composite CAE \(p. 245\)](#) file for use in Workbench. Using the dialog box shown below, specify the HDF5 Composite CAE file which contains the materials data. Then select the folder where you want to save it. ACP saves the materials in MatML format so it can be imported into Engineering Data in Workbench.

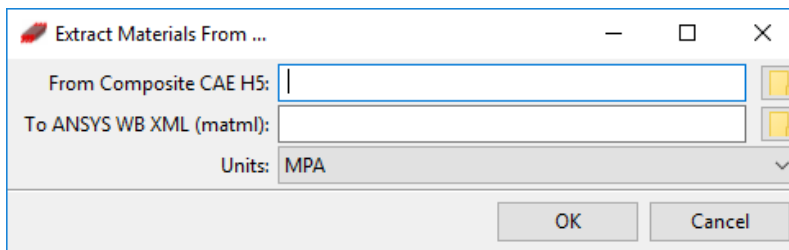
Figure 1.10: Extract Materials From Composite CAE H5... Dialog

1.3.1.3.2. Winding Wizard

The Winding Wizard generates a winding lay-up for an axisymmetric body. The Wizard is useful for creating a simple lay-up where the paths are geodesic. For more complex winding lay-ups, consider importing the lay-up from a dedicated winding tool using ACP's feature **Import from HDF5 Composite CAE File ...** (See [HDF5 Composite CAE Format \(p. 245\)](#).) CADWIND, CADFIL, and μ Wind (Mefex GmbH) are all able to export Composite CAE H5 files and generate machine code. Below are links to their websites.

- <https://www.material.be/cadwind/intro/>
- <https://www.cadfil.com/>
- <https://mefex.de/software/wind>

The Wizard uses the Origin (a point on the axis of symmetry), the Axial Direction, and the Reference Radius to automatically generate a winding lay-up for an axisymmetric body. The radius is defined as the minimal distance from any point on the surface to the axis of symmetry. The Reference Radius is equal to the radius where the layers have the nominal thickness and angle. For a typical winding body, this is the radius in the cylindrical region.

The thickness correction of each layer is calculated with:

$$\text{thickness_correction} = \text{reference_radius} / \text{radius} \quad (1.1)$$

The angle is calculated based on a geodesic path for which $\text{radius} * \sin(\text{angle})$ is constant:

$$\text{angle} = \arcsin(\text{const} / \text{radius}) \text{ if } \text{const} / \text{radius} \text{ in } [-1, 1] \quad (1.2)$$

$$\text{angle} = \text{sign}(\text{angle}) * 90 \quad (1.3)$$

otherwise with

$$\text{const} = \text{reference_radius} * \sin(\text{nominal_angle}) \quad (1.4)$$

Each layer has the following properties, which can be defined in the table:

- **Fabric:** Fabric of the layer (Stackups and Sublaminates are not supported).
- **Angle:** Nominal angle at Reference Radius with respect to the axis of symmetry (in degrees).
- **Ply limits:** If "Has limits" is true, the ply ends at the locations defined by the "Upper Limit" and "Lower Limit" column. The "Upper Limit" and "Lower Limit" values are interpreted as distance from the origin along the axial_direction.
- **Add mirrored ply:** If set to True, an additional layer with the same properties but a negative angle is generated. This implies that the resulting thickness is twice the original thickness of the layer.

You can also import the layers from a CSV file with the **Import from CSV** button. Columns are Fabric Id, Nominal Angle, Has Limits, Lower Limit, Upper Limit, and Add Mirrored Ply. Example Row:

```
Fabric.1,30,True,0,1,False
```

The Wizard generates the following objects:

- A cylindrical Rosette
- An Oriented Selection Set which defines a reference direction along the axial direction of the axisymmetric body
- A Lookup Table with the thickness corrections and angles
- A template Selection Rule if limits are defined
- A Modeling Group with the Plies

Once the lay-up is generated, you can manually adjust it. For example, you can edit the thicknesses and angles in the Look-up Table or edit the parameters of the Selection Rule.

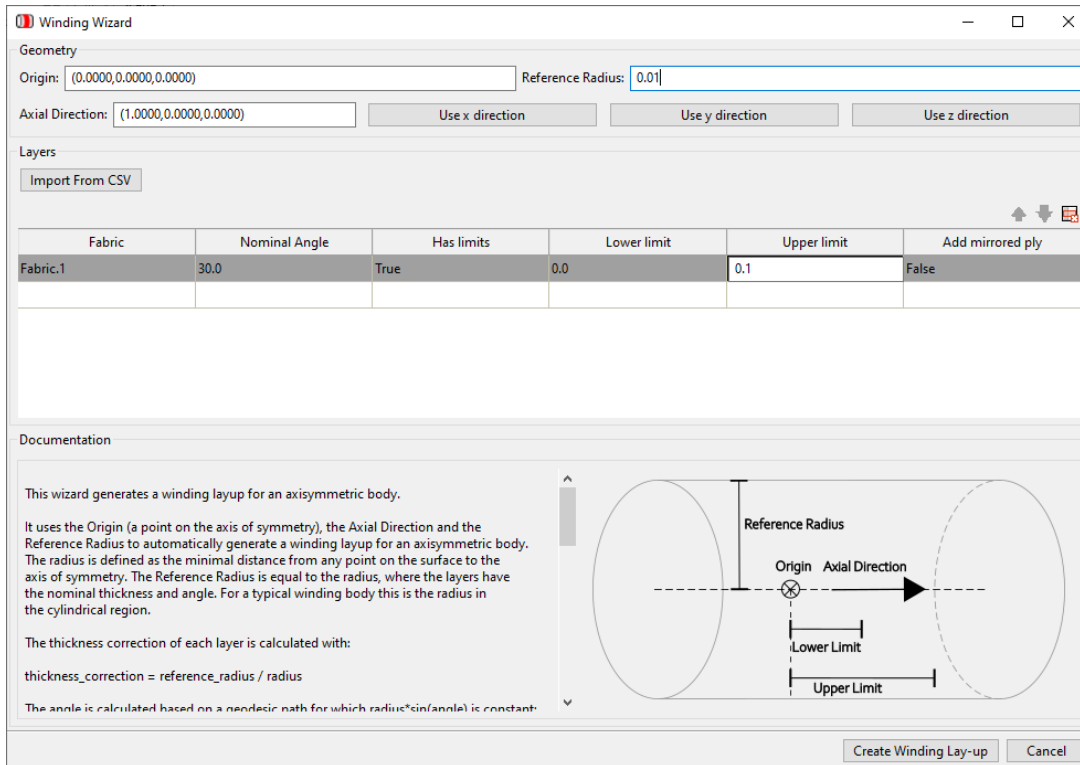
Figure 1.11: Winding Wizard with the Inputs on Top and the Description at the Bottom

1.3.1.3.3. Migration Helper

The **Migration Helper** tool enables migrating previous composite analyses to the Mechanical application. For more information, see [ACP \(Post\) to Mechanical Software Migration](#) (p. 54).

1.3.1.3.4. Preferences

You can configure the following application settings through the **Preferences** submenu:

- [Add Ons](#) (p. 17)
- [Ansys Product Improvement Program](#) (p. 17)
- [General ACP Preferences](#) (p. 17)
- [Logger Settings](#) (p. 18)
- [Material Database](#) (p. 18)
- [Notifications and Pop-ups](#) (p. 19)
- [Scene Preferences](#) (p. 19)
- [Section Generation](#) (p. 20)
- [Units](#) (p. 20)

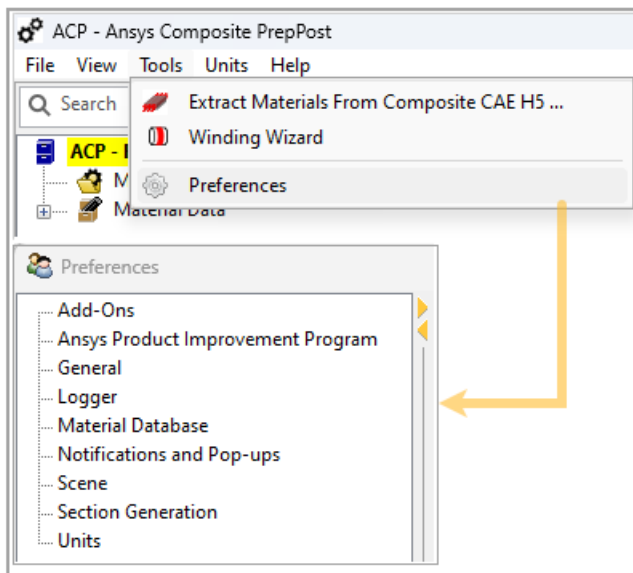
Figure 1.12: Preferences Window

1.3.1.3.4.1. Add Ons

Add-Ons: Activate or deactivate the available add-ons (p. 3).

1.3.1.3.4.2. Ansys Product Improvement Program

Ansys Product Improvement Program: Here you can opt to participate in the Ansys Product Improvement Program. Refer to the section [Ansys Product Improvement Program \(p. 5\)](#) for complete information.

The option applies only to workflows in ACP standalone operation. For Workbench workflows, you must opt into the Ansys Product Improvement Program using the Workbench settings.

1.3.1.3.4.3. General ACP Preferences

In the **General** heading, the following options are available:

Ansys Executable Path: Path to the `ansys.exe` file (solver). If empty, ACP uses the default path from the installation.

Ansys License: Defines which license will be used to solve the model. For more information on licenses, see [Product to License Feature Mapping in the Ansys, Inc. License Management Guide](#). The **Feature Name** (from the Ansys Product to License Feature Mapping Table) should be typed in this field. For example, enter `struct` for an Ansys Mechanical Enterprise Solver. By default, the **Ansys License** field is empty, in which case ACP uses the order of licenses defined in the [LM Center](#).

Number of Threads to Use in Parallel: Specifies the number of cores/threads used for computation. ACP uses all available cores when the option is zero (default).

H5 Compression Level: Specify the GZip compression level of HDF5 (storage format of ACP). The default setting is 2. This setting provides good compression at an overhead of about 35% when compared to no compression (setting of 0). The highest available setting is 9. Note that processing requirements increase based on this setting. You will

notice an increase in processing times with a setting of 4 and above. You need to evaluate the benefits of increased processing time versus file size reduction.

Figure 1.13: General ACP Preferences

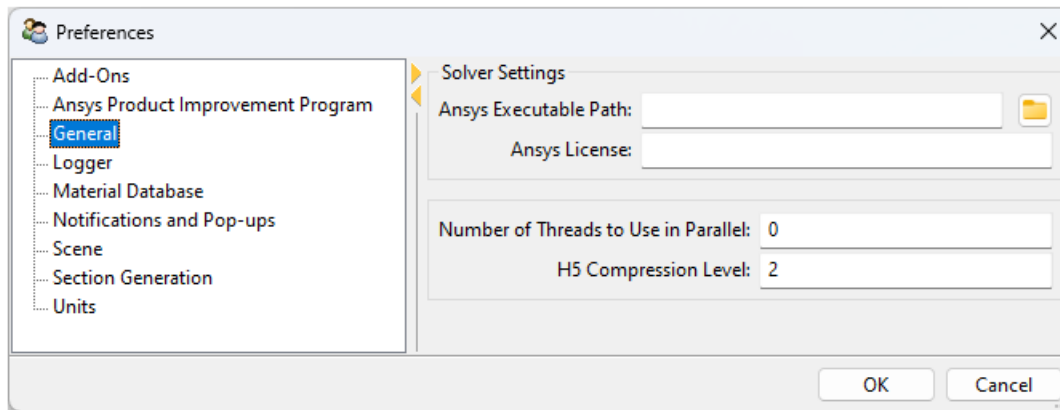

1.3.1.3.4.4. Logger Settings

Use the **Logger Settings** dropdown menu to set the severity level of messages displayed in the Log Window. The levels are:

- Debug:** Log everything, including debugging information.
- Info** (default): Log everything, except debugging information.
- Warning:** Log errors and warnings.
- Error:** Log errors only.
- Critical:** Not used.

Number of Days to Keep Log Files: Specify how long the ACP log files are retained. By default, ACP deletes files older than seven days. Note that keeping a large number of log files slows down the ACP startup.

Figure 1.14: Logger Preferences

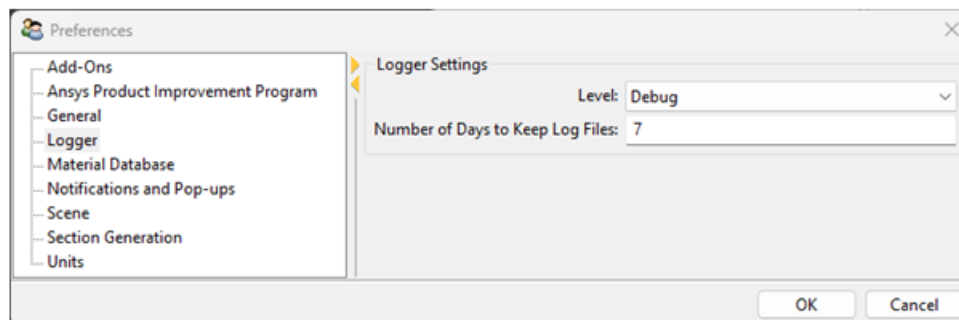

1.3.1.3.4.5. Material Database

Material Database: Define the path to the material database (.acpMdb file). See [Material Database](#) (p. 244).

1.3.1.3.4.6. Notifications and Pop-ups

Notifications and Pop-ups: Enable or disable notifications and confirmation dialogs.

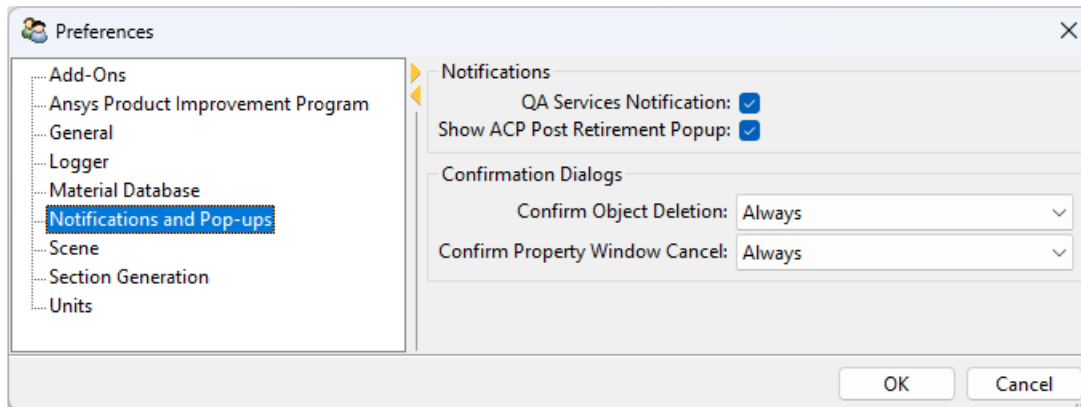

1.3.1.3.4.7. Scene Preferences

In the **Scene** heading, some graphical properties of the model display can be modified. These properties are grouped in three parts:

Figure 1.15: Scene Preferences

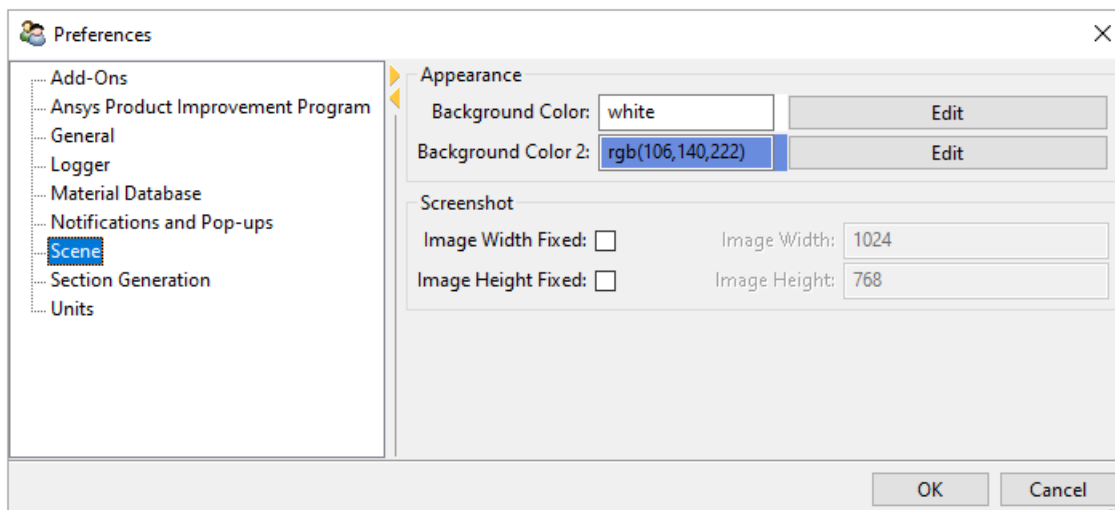

- **Appearance:** Background color of the Scene window can be defined as uniform or as a gradient from bottom to top. To obtain a uniform background, **Background Color** and **Background Color 2** should have the same color definition. When defining a top to bottom gradient, **Background Color** is the bottom color and **Background Color 2** is the top color. To modify these colors click **Edit**.
- **Screenshot:** By default, the size of the image captured by the Snapshot utility has the same size as the Scene size. The size of the captured image can be fixed to a certain dimension. This option should be used carefully.

1.3.1.3.4.8. Section Generation

Section Generation: Define default tolerance values for the generation of sections and the minimum analysis ply thickness. For more information see [Lay-Up Computation](#) (p. 65).

Figure 1.16: Section Generation Preferences

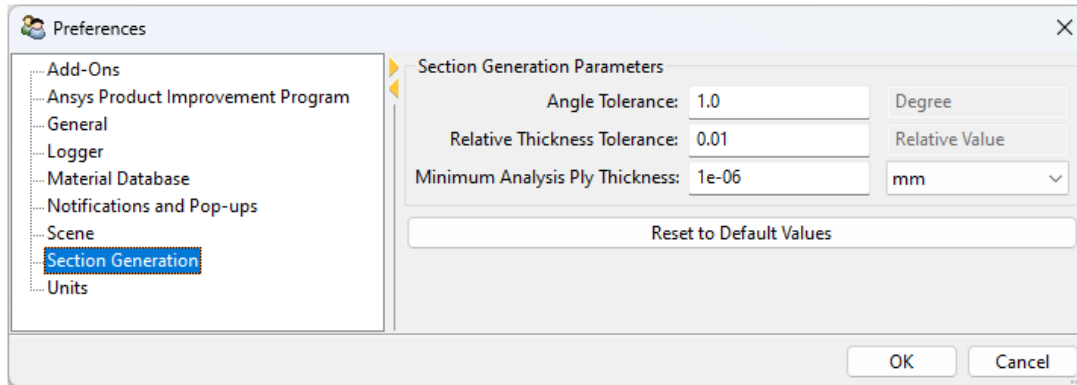

1.3.1.3.4.9. Units

You use the **Units** menu to change the active unit system.

Figure 1.17: Units Menu

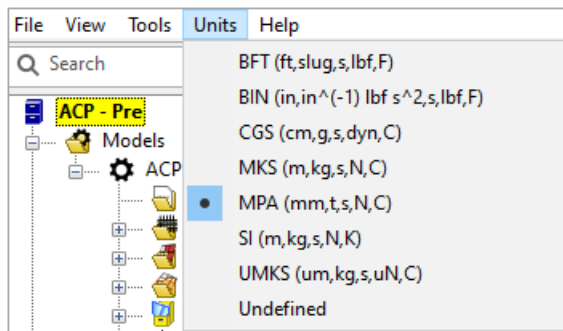

The unit system can only be altered in preprocessing. It is locked in shared mode and postprocessing. When changing from a predefined unit system to **Undefined**, or vice versa, no conversions take place.

The unit system of the active model is displayed in the status bar at the bottom of the ACP window.

Table 1.1: Predefined Unit Systems

Name	Length	Mass	Time	Length*Mass/Time ²	Temperature	Currency
BFT	ft	slug	s	lbf	F	USD
BIN	in	1/in*lbf/s ²	s	lbf	F	USD
CGS	cm	g	s	dyn	C	USD
MKS	m	kg	s	N	K	USD

Name	Length	Mass	Time	Length*Mass/Time ²	Temperature	Currency
MPA	mm	t	s	N	C	USD
SI	m	kg	s	N	K	USD
UMKS	μm	kg	s	μN	C	USD
Undefined	-	-	-	-	-	-

1.3.2. Tree View

The underlying Python Object Tree (see [The ACP Python Scripting User Interface \(p. 56\)](#)) is mapped into the graphical Tree View. It provides an easy way of selecting objects or viewing/modifying the state of an object. An explanation on how to modify specific objects in the Tree is provided in the [Usage Reference \(p. 61\)](#).

Most Tree objects are associated with a context menu, which can be displayed by right-clicking the object. Double-clicking a Tree object directly opens the **Properties** dialog for that object - providing a shortcut from opening the context menu.

The Tree View is accompanied with a toolbar that is located at the top of the Tree View. The following functions are available:



- Search allows you to search for Tree objects which have a name matching the search string.
- The collapse button folds the Tree back into its original state.

Note:

The search is case-insensitive and requires an exact match. Special characters are not treated as wild cards and are not ignored in the search and object name strings. For example, a search for "test object 1" will not return a match for an object named **test_object_1**. Similarly, a search for "test_object_*" will not return a match for an object named **test_object_1**.

Caution:

Care should be taken when defining objects while Tree filtering is active. The object selection must be consistent with what is displayed in the filtered Tree. It is recommended that you clear any Tree filters while defining new objects.

Figure 1.18: Tree View

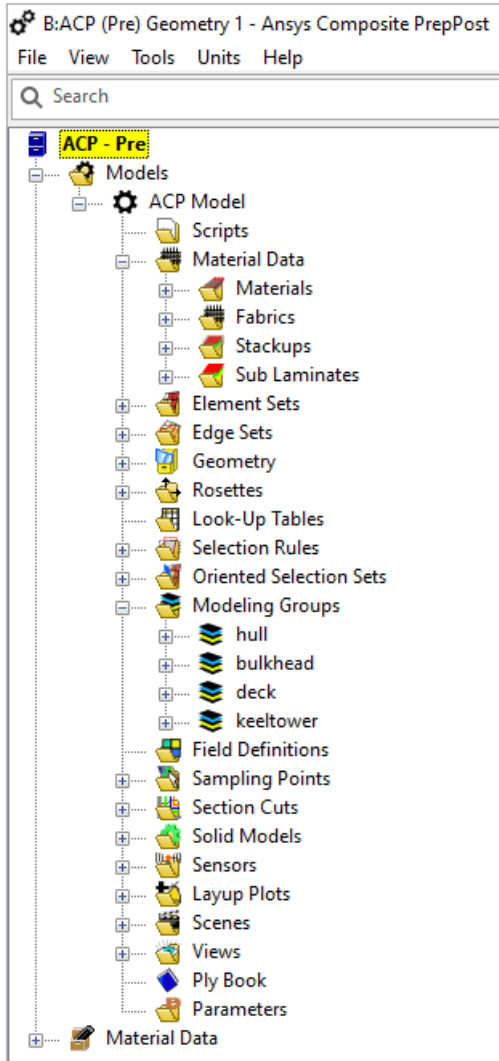

A status symbol appears for each item.

Figure 1.19: Locked Rosettes and the Update Status

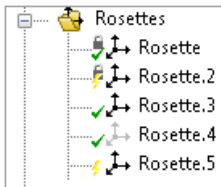



: Rosette is locked and up-to-date.

: Rosette is locked but not up-to-date.

: Rosette is updated.

: Rosette is hidden.

: Rosette is not updated. It can be updated with the general update in the toolbar or context menu.

The symbol  indicates that this object is defined, but inactive and therefore not considered in any evaluation. Among many others, Modeling Plies, Solid Models and Analysis Plies can be inactive.

You can move through the Tree using the arrow keys. The sub-trees are automatically reduced and expanded.

Special shortcuts exist for the **Modeling Group**. For more information, see [Usage Reference \(p. 61\)](#).

1.3.3. Scene

The Scene contains a 3D graphical representation of the model and all defined entities. There is no limit to the number of Scenes that can be created, and changing from one Scene to another can be done with a single click. You can navigate through the Scene by mouse or keyboard input. For more information, see [Scene Manipulation \(p. 23\)](#).

1.3.3.1. Scene Manipulation

The view of the Scene can be manipulated using several buttons on the toolbar:

: Standard views along each axis.

: Zoom to fit the model.

: View full-screen.

: Active or deactivate perspective.

: Capture screenshot.

1.3.4. Toolbar

The toolbar interacts with the Scene by modifying camera views or displaying or hiding elements:

1.3.4.1. Updates

1.3.4.2. Edit Entities with Excel

1.3.4.3. Scene Options

1.3.4.4. Mesh Appearance

1.3.4.5. Orientation Visualization

1.3.4.6. Fiber Directions

1.3.4.7. Draping

1.3.4.8. Other Features

1.3.4.9. Configure Plots



1.3.4.1. Updates

After some operations (for example, reloading the model, modification of one or more plies, or activating postprocessing), an update (⚡) of the Scene is necessary.

1.3.4.2. Edit Entities with Excel

: Create, edit, or save the entities such as Look-up Tables or Modeling Plies with Excel.

The Excel Link interface allows you to define, modify, or save the lay-up definition in an Excel spreadsheet. The lay-up can be transferred to a spreadsheet using the push function or a lay-up which has been defined in a spreadsheet can be imported into ACP using the pull function. By default, all lay-up data is synchronized between Excel and ACP. Alternatively, you can select specific Modeling Groups for which the lay-up is synchronized. In addition, Pull Mode controls how the lay-up is transferred to ACP. The lay-up can be linked to a new spreadsheet or to an existing one. The latter functionality gives you the ability to restore a lay-up from pre-defined data.

Figure 1.20: Excel Link Dialog

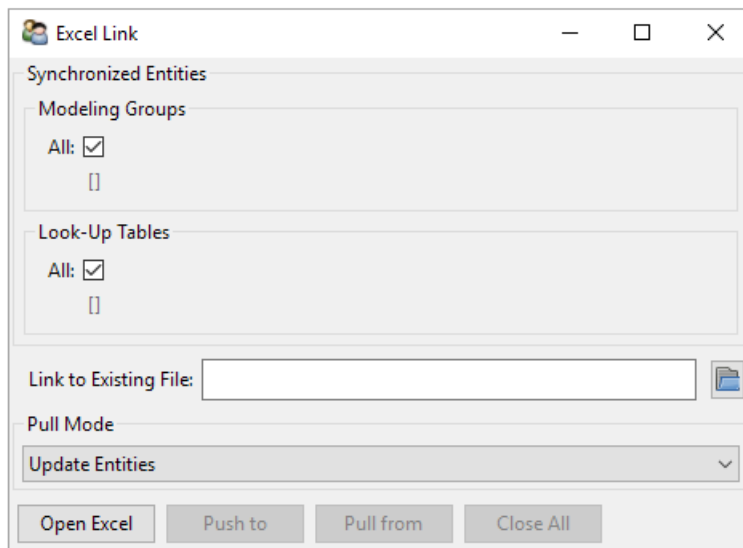

The main functions of the Excel Link are:

- **Open Excel:** Open an existing Excel file if specified. If no path is specified, a new worksheet is opened and filled with the current lay-up information.
- **Push to:** Sync lay-up definition data from ACP to Excel.
- **Pull from:** Read definition data from Excel and update the definition in ACP.
- **Close All:** Close Excel and the ACP Dialog Box.















The following options are available for Pull Mode:

- **Update Entities:** During a **Pull from** operation, definitions are updated, additional plies are generated and deleted according to Excel data.

- **Update Properties Only:** During a **Pull from** operation, definitions are updated with properties given.
- **Recreate Entities:** During a **Pull from** operation, existing lay-up is deleted and generated from scratch. The ACP Tree order corresponds to the Excel spreadsheet order.









1.3.4.3. Scene Options

In the ACP application, the scene can be modified with the following buttons:

- : Camera positions. Place the camera along the coordinate system axes, pointing towards the rotation center.
 - : Camera placed along the positive x axis.
 - : Camera placed along the negative x axis.
 - : Camera placed along the positive y axis.
 - : Camera placed along the negative y axis.
 - : Camera placed along the positive z axis.
 - : Camera placed along the negative z axis.
- : Zoom to fit the model in the Scene.
- : Show the Scene in Fullscreen mode. Press Esc to exit full screen mode.
- : Switch between parallel and perspective projection.
- Change the lighting mode of the scene:
 - : (Dark mode) The model geometry is highlighted with pronounced shadows. This mode matches the lighting mode of ACP version 2024 R2 and before.
 - : (Light mode) Show only reduced shadows.
 - : (No shadows) All surfaces are fully lit. This mode should be preferred when comparing colors in a plot.
- : Create a View that captures the current Scene
- : Create a screenshot from the current Scene

1.3.4.4. Mesh Appearance

Appearance of the mesh can be modified using several buttons on the toolbar:

- : Show or hide element edges.
- : Show or hide the mesh surface.
- : Show or hide the silhouette of the mesh. For huge meshes, this function is computationally expensive. This will prevent Scene manipulation while it is processing.
- : Highlight elements.
- : Highlight silhouette of selected elements even if it is hidden by mesh.
- Element Selection Mode: The button icon changes depending on which mode is active:
 - : Automatically highlight shell or solid elements when an object of a shell or solid model is selected. For example, when an Analysis Ply under a [Solid Model \(p. 184\)](#) is selected, that element on the model is highlighted.
 - : Highlight only shell elements. When an object of a solid model is selected (for example, a Mesh Component of a [Solid Model \(p. 184\)](#)), nothing is highlighted.
 - : Highlight only solid elements. If the selected object is not part of a solid model (for example, a Modeling Ply or a Production Ply), nothing is highlighted.
- : Display probe values when hovering over model.

1.3.4.5. Orientation Visualization

You can display the surface orientations using the orientation buttons on the toolbar.

Figure 1.21: Orientation Visualizations in the Toolbar

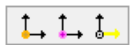

- : Display element normals or normal direction of CAD geometry parts.

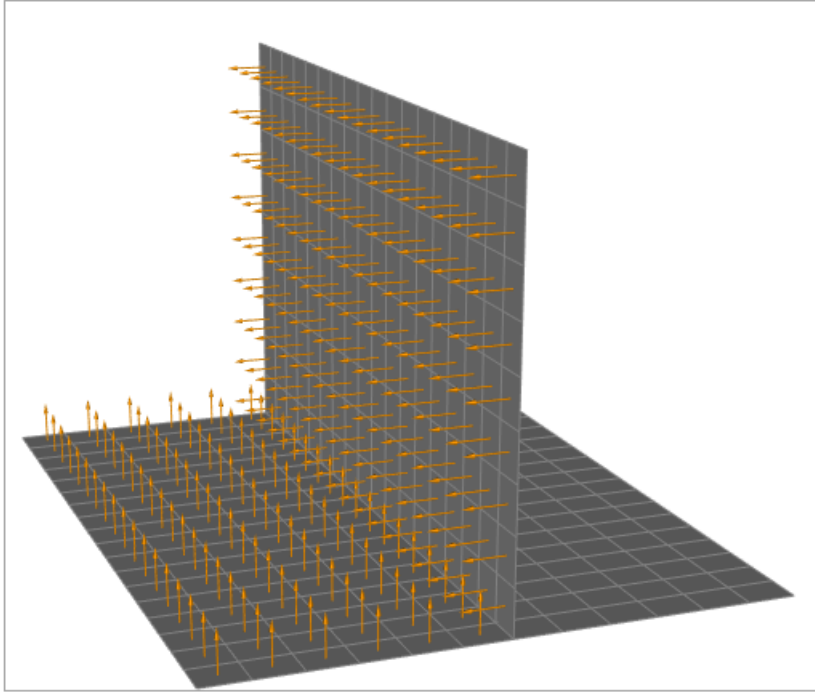
Figure 1.22: Visualization of the Element Normals

: Display orientation of an Oriented Selection Set (OSS).

Figure 1.23: Visualization of the OSS Normal

: Display reference direction of an Oriented Selection Set (OSS).

Figure 1.24: Visualization of the OSS Reference Direction

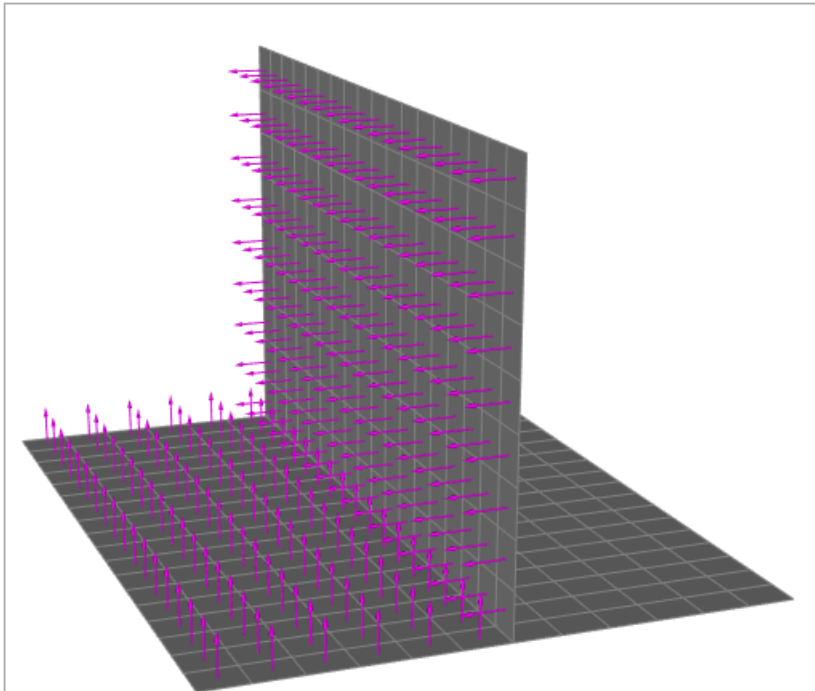

1.3.4.6. Fiber Directions

The ply angles can be visualized with the fiber direction buttons on the toolbar.

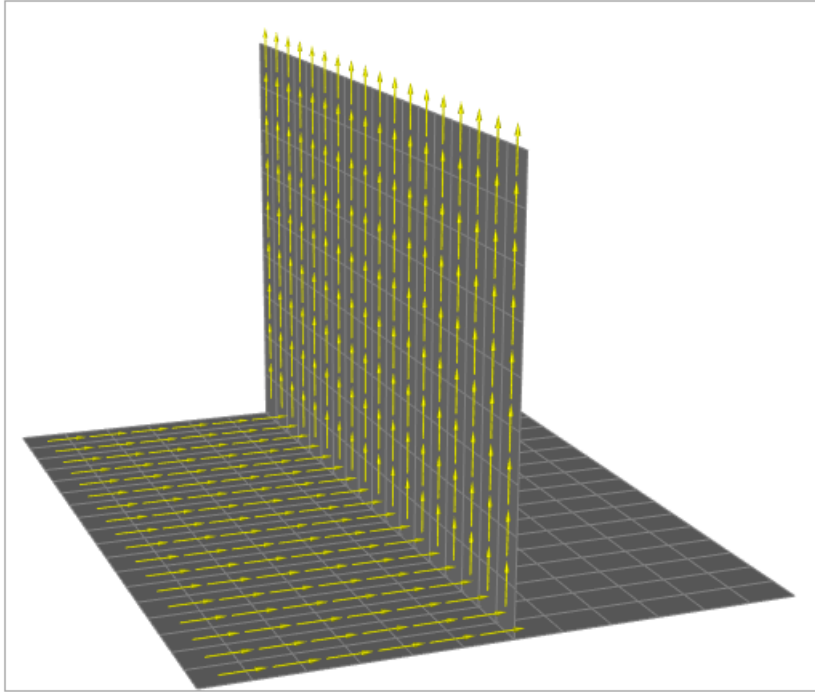
Figure 1.25: Fiber Directions in the Toolbar

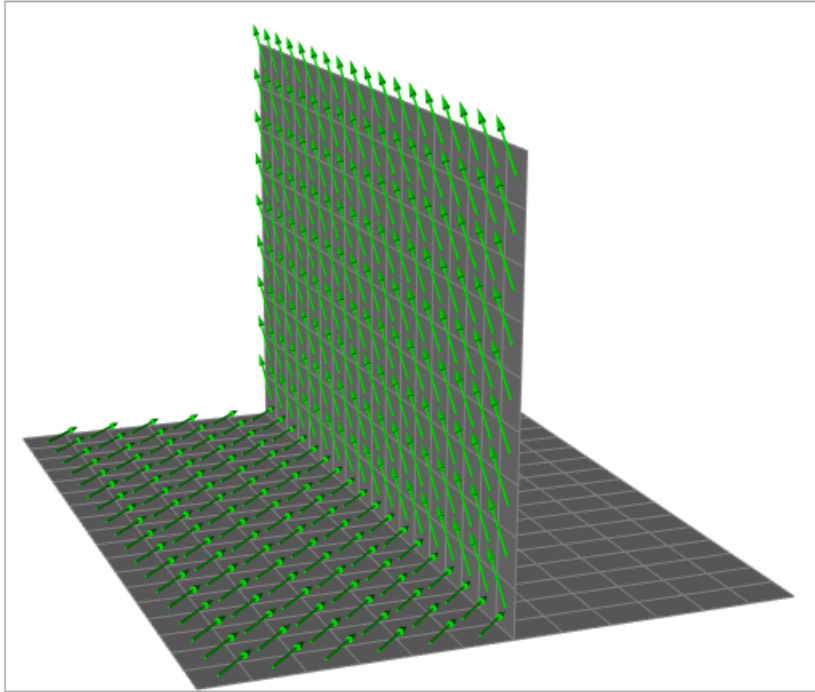

: Display the fiber direction of the selected ply.

Figure 1.26: Visualization of the Fiber Direction

: Display the transverse ply direction.

Figure 1.27: Visualization of the Transverse Ply Direction

1.3.4.7. Draping

You can highlight the draping effect by comparing the fiber direction (see [Fiber Directions \(p. 28\)](#)) with the draped fiber direction as well as the transverse fiber direction with the transverse draped

fiber direction. Moreover, if the [Fabric Fiber Angle \(p. 78\)](#) property is active, its effect can be visualized by plotting the Material 1 Direction of the selected analysis ply.

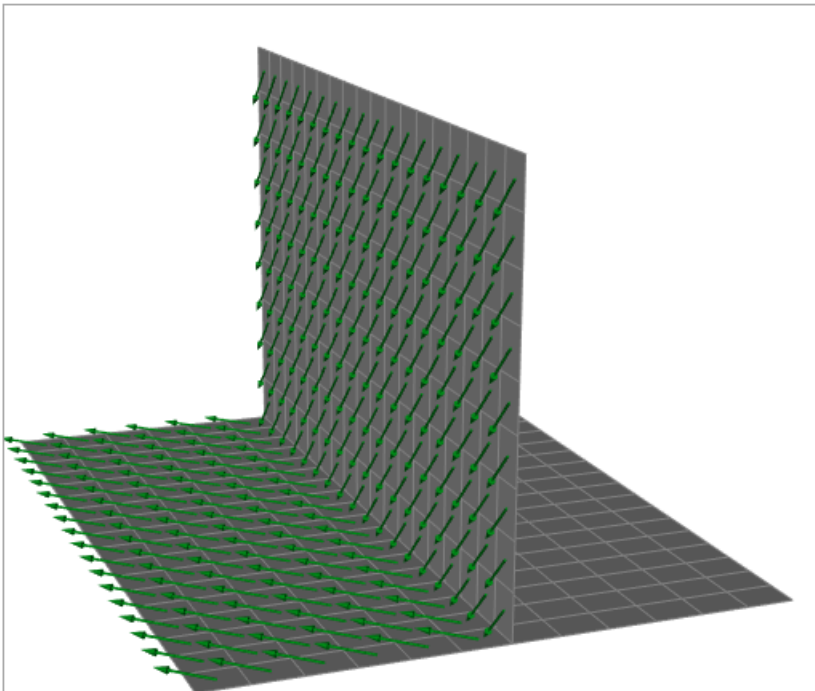
Figure 1.28: Draping Directions in the Toolbar



: Plot Draped Fiber Directions.

Figure 1.29: Fiber Directions (Defined and Draped)

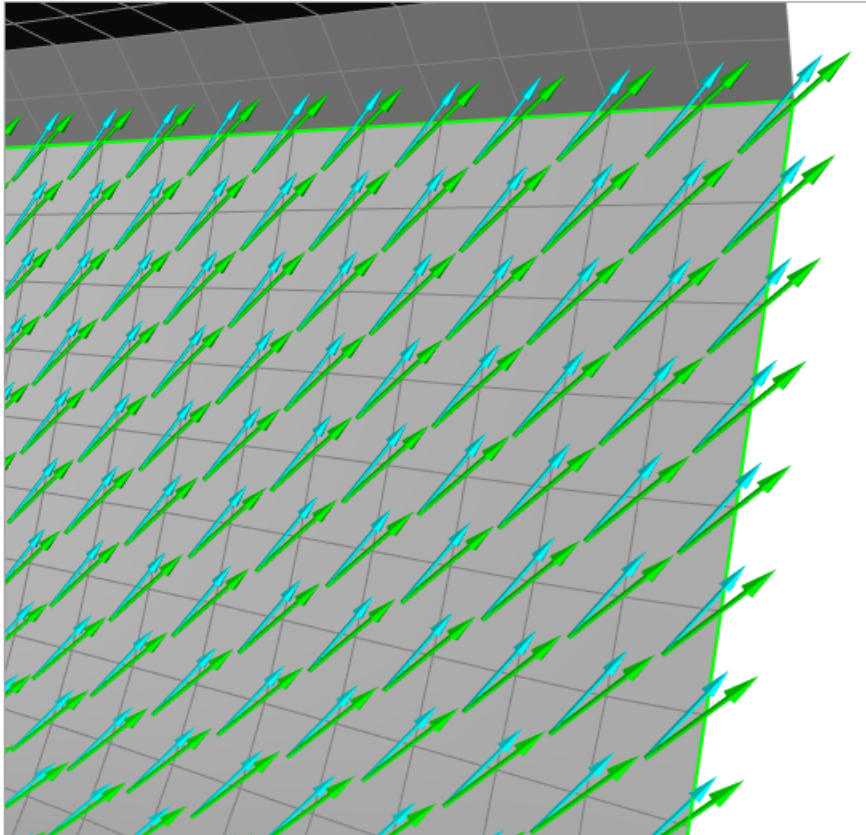

: Plot Draped Transverse Fiber Directions.

Figure 1.30: Traverse Directions (Defined and Draped)

: Plot Material 1 Directions.

Figure 1.31: Material 1 Direction and Draped Fiber Direction for a Material with a 45° Fabric Fiber Angle

1.3.4.8. Other Features

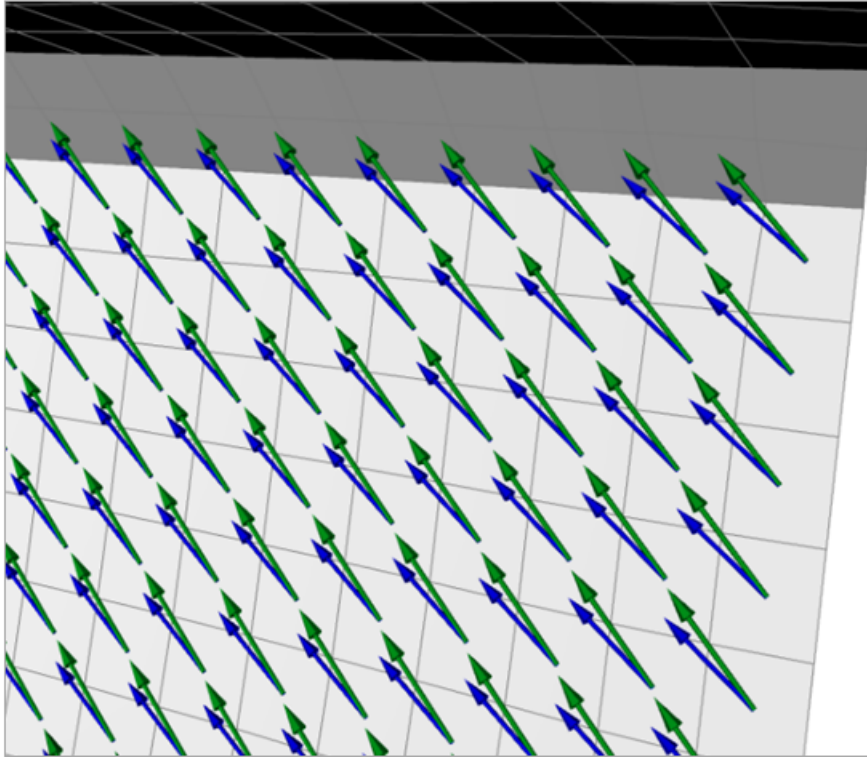
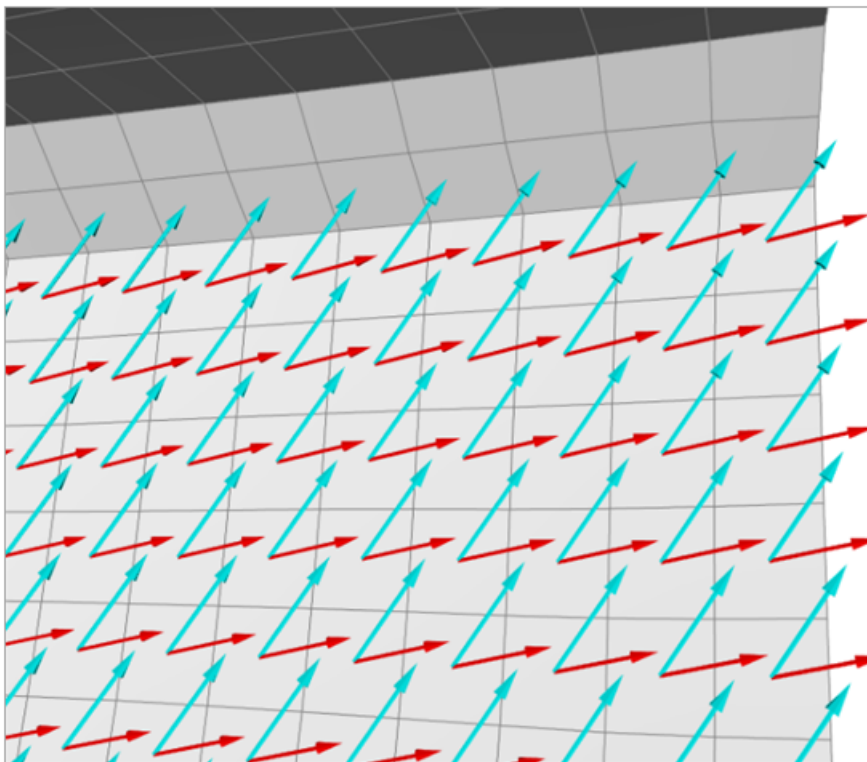
The toolbar displays the following additional features:

- : Display or hide the coordinate system axis.

A coordinate system axis is displayed by default in the bottom left corner of the graphics window for a better 3D orientation.

- : Plot box with coordinate system.

Figure 1.32: Enclosed Box and Coordinate System





- : Distance measure tool. Select two points of the mesh and the distance and point coordinates will be displayed in the bottom left.

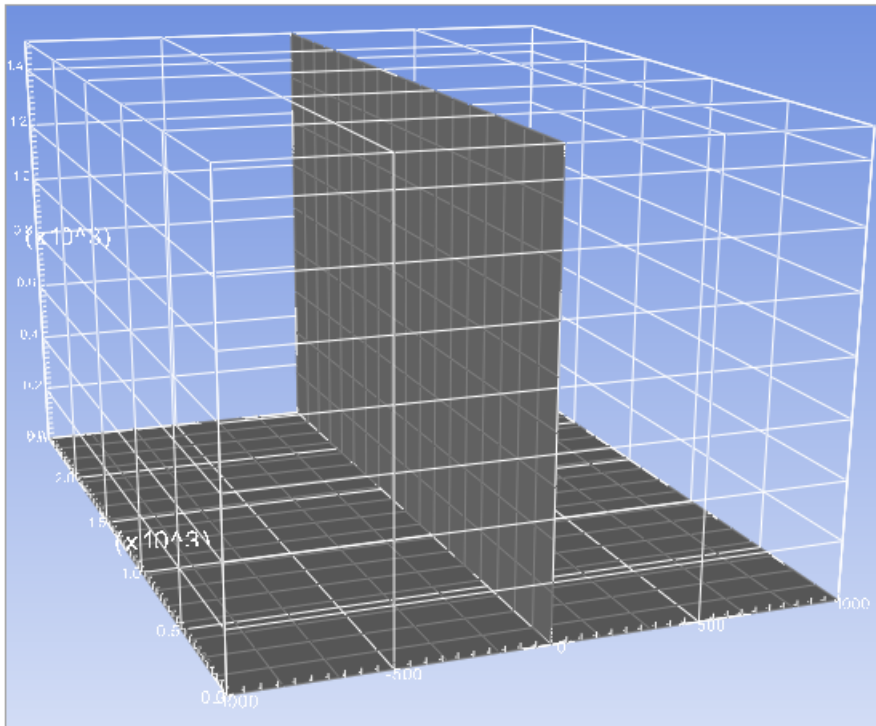

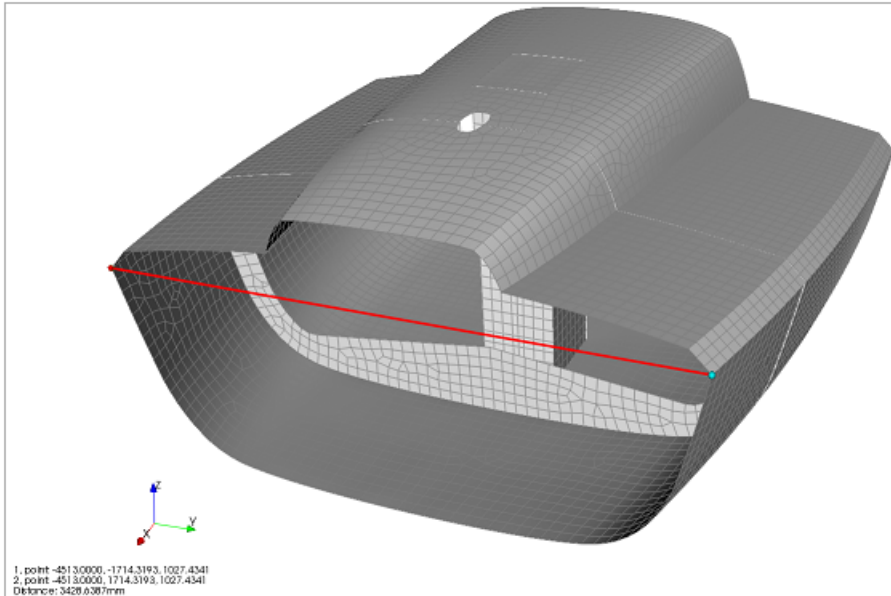

Figure 1.33: Distance Measure Tool

1.3.4.9. Configure Plots

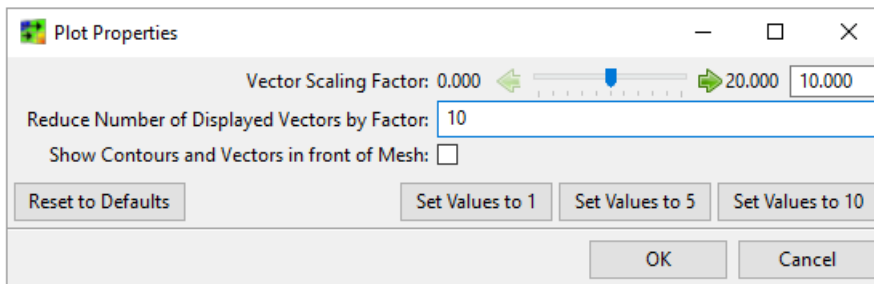
Configure the objects displayed in the Scene.

- 
Plot Properties: Configure vector density and length for the direction plots. In addition, you can specify whether vectors and contour plots are always shown in front of the mesh.



- 
Show Legend: Show / hide the plot legend.
- 
Toggle Text Plot: Show / hide text labels in plots, such as Failure Mode or User-Defined Text.
- 
Show Min/Max Labels: Show / hide labels highlighting the minimum and maximum value of a plot. Note that the labels are not shown when Ply Offsets are active.
- 
Show Description: Show / hide the plot description in the top left corner of the scene.
- 
Show Deformed Shape: Select whether the plot is shown on the original or deformed mesh.

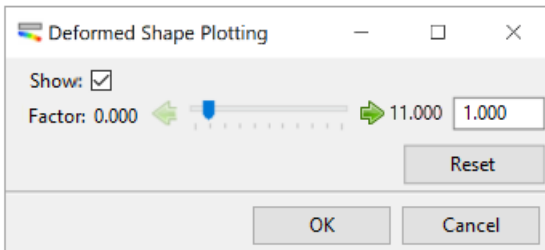

1.3.5. View Panes

The View panes displayed at the bottom of the interface contain specific information about the processes performed. You can rearrange the Views using drag and drop. A red highlight displays the new (drop) position for placing the View. Each View is described below.

1.3.5.1. Shell View

All commands performed through GUI interactions are executed by the internal Python interpreter. The same commands can be entered manually in the Shell View window. The Shell View window also provides standard text editing features such as copy and paste, history, and tab completing.

A detailed overview about scripting in ACP and a command reference can be found in [ACP Python Scripting User Interface](#) (p. 56).

Code Completing and Help

The period (".") activates the code completing. Use the Up Arrow, Down Arrow, or the mouse to navigate through the drop-down menu. **[TAB]**, **[ENTER]** or double-clicking inserts the selected command.

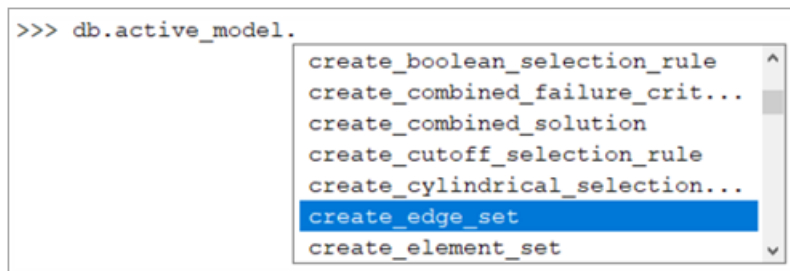

Enter an opening parentheses "(" to get help on the selected method. Press **[ENTER]** to insert the function header.

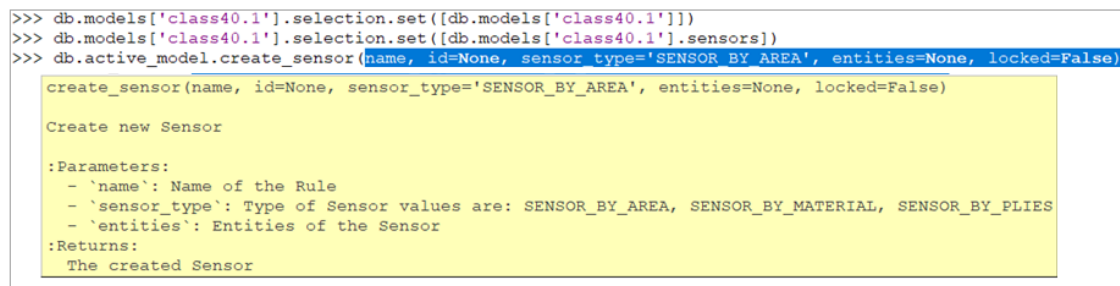

The context menu of the Shell View windows is accessible by a right-click and it allows you to copy and paste commands. Use **"Paste and Run"** to execute multi-line or multiple statements.

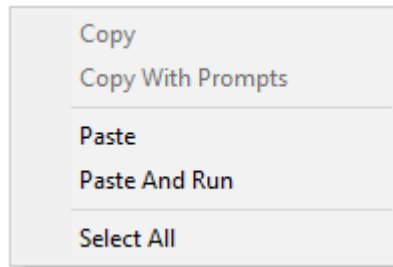

1.3.5.2. Keyboard Shortcuts

Here is the list keyboard shortcuts of the Shell View window that allow you to access the history, copy, and paste commands, and so on.

Selection

Home	Go to the beginning of the command or line.
End	Go to the end of the line.
Shift + Home	Select back to the beginning of the command or line.
Shift + End	Select to the end of the line.

Copy and Paste

Ctrl + C	Copy selected text, removing prompts.
Ctrl + Shift + C	Copy selected text, retaining prompts.
Ctrl + V	Paste from clipboard.
Ctrl + Shift + V	Paste and run multiple commands from clipboard.

History

Ctrl + Up-Arrow	Retrieve previous history item.
Ctrl + Down-Arrow	Retrieve next history item.
Shift + Up-Arrow	Insert previous history item.
Shift + Down-Arrow	Insert next history item.

Font Size

Ctrl +]	Increase font size.
Ctrl + [Decrease font size.
Ctrl + Wheel	Edit font size.
Ctrl + =	Default font size.

1.3.5.3. Logger

The information saved in the file `%APP_DATA%\Ansys\v251\acp\ACP.log` is shown in this View. The severity level of the logged events is defined in [Logger Settings \(p. 18\)](#).

1.3.5.4. History View

All commands processed during the existing session are stored in the Python command history. They can be inspected in the History View window, where each text line refers to an executed command. The command history is also available in the Shell View by using the **Ctrl + Up / Ctrl + Down** keys.

1.3.6. Keyboard Shortcuts

ACP provides keyboard shortcuts for executing common operations.

1.3.6.1. General Shortcuts

1.3.6.1.1. Scene View Shortcuts

1.3.6.1.2. Tree View Shortcuts

1.3.6.1.3. Shell View

1.3.6.1.4. Properties Windows

1.3.6.1. General Shortcuts

Workbench mode

Ctrl+S	Save Project (entire WB project)
Ctrl+Shift+S	Save ACP Database as new file
Ctrl+R	Run Script
Ctrl+H	Open ACP Documentation

In Standalone mode

Ctrl+O	Open ACP Database
Ctrl+S	Save ACP Database
Ctrl+Shift+S	Save ACP Database as new file
Ctrl+W	Close active Model
Ctrl+Shift+W	Close all Models
Ctrl+I	Import Model
Ctrl+R	Run Script
Ctrl+H	Open ACP Documentation

1.3.6.2. Scene View Shortcuts

The following keyboard shortcuts are available in the Scene View pane. See also the section, [Scene \(p. 23\)](#).

Scene View

Left-Click	Select Element
Left-Click (drag)	Select multiple Elements
Middle-Click	Set rotation center

Middle-Click (drag)	Rotate Camera
Ctrl+Middle-Click (drag)	Move Camera
Right-Click (drag)	Zoom to selected area
Scroll wheel	Zoom in / out

1.3.6.3. Tree View Shortcuts

The following shortcuts are available in the Tree View pane. Also [Tree View \(p. 21\)](#).

Tree View

Up-Arrow	Go up in tree
Down-Arrow	Go down in tree
Right-Arrow	Expand tree group
Left-Arrow	Collapse tree group
[Go to previous ply of the same kind
]	Go to next ply of the same kind
F2	Rename object
Ctrl+C	Copy object(s)
Ctrl+X	Cut object(s) ^[a]
Ctrl+V	Paste object(s)
Del	Delete object(s)
Mouse-Click+Drag	Drag-and-drop object(s) ^[b]

^[a] Cut-and-paste and drag-and-drop are implemented only for the following object types: Script, Modeling Group, Modeling Ply, Interface Layer, Butt Joint Sequence, and Extrusion Guide.

^[b] See [Reordering Modeling Plies, Interface Layers, and Butt Joint Sequences \(p. 155\)](#) for details on how cut-and-paste and drag-and-drop affect the Global Ply Number.

1.3.6.4. Shell View

The following shortcuts are available in the Shell View pane. See also [View Panes \(p. 34\)](#).

Selection

Home	Go to the beginning of the command or line.
End	Go to the end of the line.
Shift+Home	Select back to the beginning of the command or line.
Shift+End	Select to the end of the line.

Copy and Paste

Ctrl+C	Copy selected text, removing prompts.
Ctrl+Shift+C	Copy selected text, retaining prompts.
Ctrl+V	Paste from clipboard.
Ctrl+Shift+V	Paste and run multiple commands from clipboard.

History

Ctrl+Up-Arrow	Retrieve previous history item.
Ctrl+Down-Arrow	Retrieve next history item.
Shift+Up-Arrow	Insert previous history item.
Shift+Down-Arrow	Insert next history item.

Font Size

Ctrl+]	Increase font size.
Ctrl+[Decrease font size.
Ctrl+Wheel	Edit font size.
Ctrl+=	Default font size.

1.3.6.5. Properties Windows

Properties Window Shortcuts

Esc	Discard changes and close the Properties window
Ctrl+Enter	Save changes and close the Properties window.

In the **Properties Windows**, mouse interactions can be used to quickly define properties.

- **Select Position:** Click the model to define a coordinate.
 - Selecting a node returns its coordinates.
 - Selecting an element returns its centroid.

Application example: Defining the origin of a Rosette.
- **Select Direction:**
 - Option 1: **Ctrl+Click** the start point, then **Ctrl+Click** the end point of the vector. Points can be either nodes or elements. For nodes, its coordinates are used. For elements, its centroid is used.
 - Option 2: Click an element to get the normal direction of the element.

Application example: Defining the directions of a Rosette.

1.4. Implementation in Workbench

In Workbench, the ACP analysis component can be used from basic analysis to complex load cases and analyses. The following sections contain some examples of common use of the ACP analysis system.

1.4.1. Basic Workflow

1.4.2. ACP Component Properties

1.4.3. Supported Analysis Types

1.4.4. Multiple Load Cases and Analyses

1.4.5. Shared Composite Definition for Different Models

1.4.6. Solid Modeling

1.4.7. Assembly

1.4.8. Limitations

1.4.1. Basic Workflow

A composite shell defined using ACP can be imported into Mechanical for analysis by importing the mesh and composite definitions from an upstream ACP system. To import a composite shell from ACP into Mechanical, use the following procedure:

1. From the **Component Systems** list, drag and drop an **ACP (Pre)** system into the **Project Schematic**. For more information on Component Properties available in Workbench, see [ACP Component Properties](#) (p. 42).
2. Select the **Geometry** cell and specify your geometry. Make sure that you properly define your mesh, Named Selections, etc. before opening the geometry in ACP. Note that ACP only uses a linear or quadratic shell mesh.
3. Select the **Setup** cell of the ACP system. Right-click the cell and select the **Properties** option. As needed, activate the **Load Model Properties** option contained in the **Geometry** category of the **Properties of Schematic**. Selecting this property makes your geometry available in ACP's **CAD Geometries** (p. 99) object.
4. Perform all of the steps to fully define your **ACP (Pre)** system.
5. Return to the Workbench. Drag and drop a supported **Mechanical** system into the **Project Schematic**.
6. Drag and drop the **ACP (Pre) Setup** cell onto the **Mechanical** system **Model** cell to create a transfer of the model. A context menu gives you options to **Transfer Solid Composite Data** or **Transfer Shell Composite Data**. The connection enables the transfer of Mesh, Geometry, Engineering Data, and composite definitions from ACP to Mechanical. When you create this link, the **Geometry** and **Engineering Data** cells no longer display for the Mechanical system. ACP provides this system data.

You can change the **Transfer Type** if you pass the [Solid Model](#) (p. 183) to the analysis instead of the Shell Mesh, or vice-versa. For more information, see section [Transfer Types](#) (p. 42).

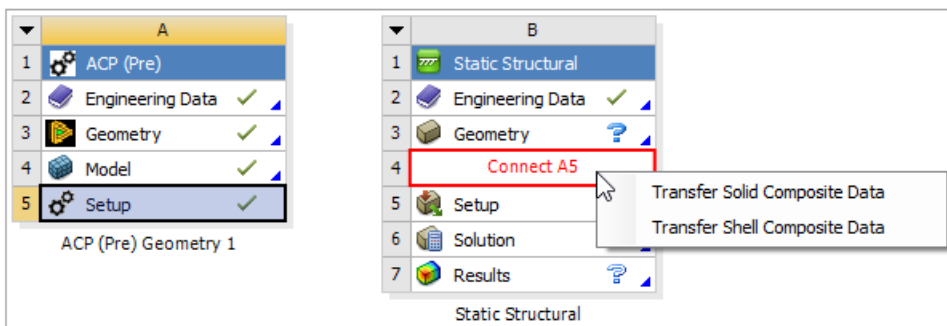

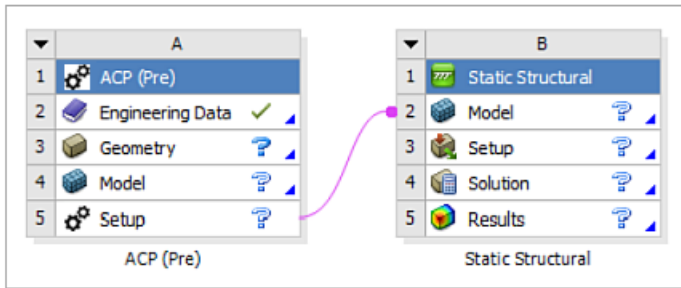

7. Double-click the **Model** cell of the **Mechanical** system. In the Mechanical application, an **Imported Plies** object is already inserted. Analysis Ply objects, corresponding to the Analysis Plies in ACP, are created under the **Imported Plies** object.

The Analysis Ply objects are grouped in Production Plies, and Production Plies are further grouped into Modeling Plies to mimic the ply structure defined in ACP:

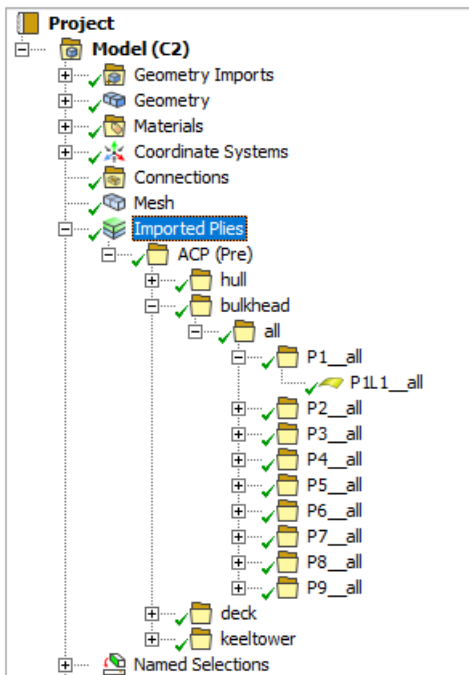

8. Perform all the steps to fully define and solve the **Mechanical** system.

The following should be noted when performing an analysis with imported ACP data:

- Since the mesh is imported from an upstream **ACP** system, any operations that affect the mesh state are blocked inside Mechanical.
- It is recommended that you do not edit the mesh inside Mechanical. However, the **Clear Generated Data** option is available on the **Mesh** object and performs the action of cleaning up the imported mesh. The **Generate Mesh/Update** operation restores the imported mesh that was previously modified.

- Since the material is assigned to elements/bodies through the upstream **ACP** system, the **Material Assignment** field is read-only and set to Composite Material.
- If the **Setup** cell of the upstream ACP system is modified, refreshing the downstream **Model** re-imports the meshes and resynthesizes the geometry. This action has the following effects:
 - Any properties set on the bodies imported from the ACP system are reset to default.
 - For solids, any scoping to geometry (bodies/faces/edges/vertices) is lost and any loads/boundary conditions scoping to geometry are lost.

Tip:

Any criterion-based Named Selections defined in the downstream Mechanical system are updated on refresh after any modification in the upstream ACP system. Since criterion-based Named Selections are automatically updated, and any direct scoping is lost, you should create criterion-based Named Selections and then scope any loads or boundary conditions to these Named Selections. This will result in persistence of scoping during modify/refresh operations.

9. Review the results. For postprocessing the layered results in the Mechanical application, see [Displaying Surface Body Results \(including Layered Shell Results\)](#) and the [Composite Failure Tool](#). The postprocessing is done in the same Mechanical system where the solution was performed.

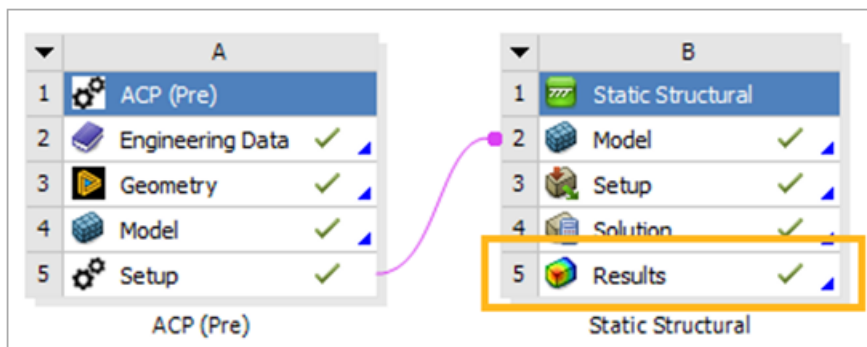

Analyses that require upstream results from Eigenvalue Buckling or Pre-Stress Modal analyses are also supported and can be transferred from the solution. Note that while postprocessing Eigenvalue Buckling or Pre-Stress Modal analyses is possible, some features such as the Composite Failure Tool are not supported.

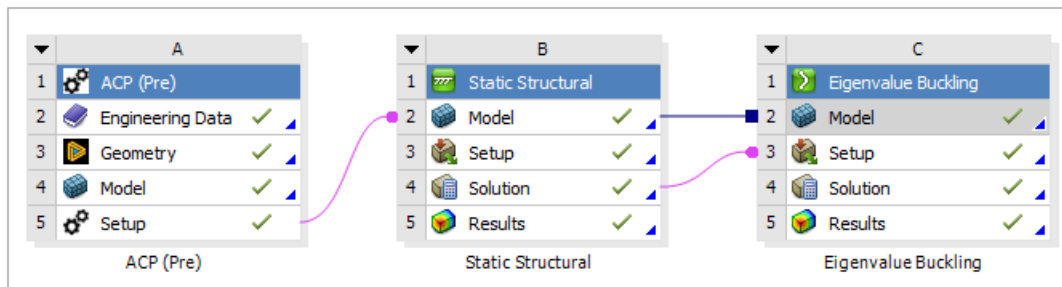

1.4.1.1. Transfer Types

One function of ACP is to model the lay-up for shell meshes or convert them into 3D layered models where the transfer type defines which lay-up definitions are passed to the downstream analysis system. For both cases, **ACP (Pre) (A5)** only shows the shell meshes (surfaces) of the loaded **Mechanical Model (B2)**. If the Mechanical Model has any solid parts, they are hidden from view.

If the transfer type is Transfer Shell Composite Data, then the shell ACP lay-up model along with the (isotropic) solid parts of the initial **Mechanical Model (B2)** are passed to the downstream Mechanical system. The lay-up definitions of **ACP (Pre) (A5)** overwrite the initial configuration (thickness, material assignment, etc.) of the shell parts of **Mechanical Model (B2)**. Shell elements that are not covered by the lay-up in ACP keep their initial properties. In addition, the solid parts of **Mechanical Model (B2)** are transferred along with the initial configuration. Therefore, they are not edited by ACP but are available in the downstream **Mechanical Model (B2)** system.

If the transfer type is Transfer Solid Composite Data, then the downstream **Mechanical Model (B2)** only contains the composite [Solid Models \(p. 183\)](#) that were added in ACP. Therefore, the initial shell and solid parts of the **Mechanical Model (B2)** are ignored.

If there is a hybrid model (with shell and solid parts) that must become a full 3D model, then the initial model must be split into two models to process both parts separately. The final model is an assembly as described in the [Assembly \(p. 50\)](#) workflow.

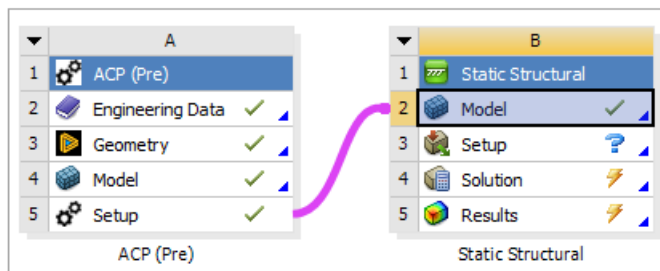

1.4.2. ACP Component Properties

The following section describes properties of an **ACP** component in Workbench. Properties can be accessed through the right-click context menu over each component cell, as shown below in [Figure 1.34: Properties from Right-Click Context Menu \(p. 43\)](#).

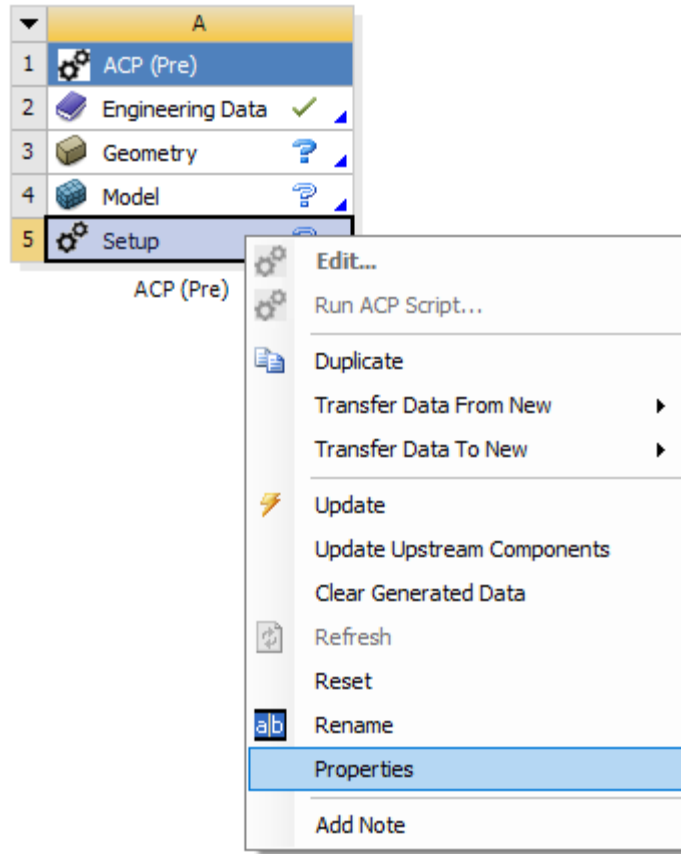
Figure 1.34: Properties from Right-Click Context Menu

From the **Setup Properties Menu**, shown below in [Figure 1.35: Properties Menu: Setup \(p. 43\)](#), the following options are available.

Figure 1.35: Properties Menu: Setup

Properties of Schematic A5: Setup		
	A	B
1	Property	Value
2	General	
3	Component ID	Setup
4	Directory Name	ACP-Pre
5	Notes	
6	Notes	
7	Used Licenses	
8	Last Update Used Licenses	
9	Geometry	
10	Load Model Geometry	<input type="checkbox"/>
11	Process Management	
12	Editor Startup Timeout (s)	90
13	Batch Mode	True batch mode

- **Load Model Geometry:** Imports the geometry from ACP's Mechanical model.

- **Editor Startup Timeout (s):** Timeout to catch an ACP start-up error. (Example: No license is available.) You can increase this value to account for license server delays.
- **Batch Mode:** Specifies the Batch Mode of ACP between **True Batch Mode** and **GUI Without Window**. By default, ACP runs in True Batch Mode so it can support cluster environments (Windows or Linux) where no graphics support is present. Note that ACP Snapshot functionality is only supported in the GUI Without Window option. If your analysis is generating Snapshots and is run by mistake in True Batch Mode, the analysis will still run to completion.

Notice that the **Editor Startup Timeout** and **Batch Mode** options are also available in the ACP Post properties.

The **Transfer Type**, which defines whether the Shell or Solid Composite model is passed to the downstream analysis, can be changed through the Properties of the downstream Mechanical model. See [Assembly \(p. 50\)](#).

1.4.3. Supported Analysis Types

The **ACP (Pre)** system can be linked with the following Mechanical analysis systems:

- Static Structural
- Transient Structural
- Steady-State Thermal
- Transient Thermal
- Modal
- Harmonic Response
- Random Vibration
- Response Spectrum
- Eigenvalue Buckling
- Explicit (LS-DYNA)

Composite postprocessing in the Mechanical application currently supports the following analysis systems:

- Static Structural
- Transient Structural

Note:

- Although both Structural and Thermal layer modeling are available, the particular degrees of freedom results on corresponding layers could behave differently in structural and thermal environments. For more information, see the [Element Reference](#) for the specific elements, particularly [SOLID185](#) and [SOLID278](#).

- MAT_002 Option ORTHO MAT_ORTHOTROPIC_ELASTIC
- MAT_002 Option ANISO MAT_ANISOTROPIC_ELASTIC
- MAT_054/055 MAT_ENHANCED_COMPOSITE_DAMAGE
- MAT_058 MAT_LAMINATED_COMPOSITE_FABRIC
- MAT_059 Option SHELL MAT_COMPOSITE_FAILURE_SHELL_MODEL
- MAT_059 Option SOLID MAT_COMPOSITE_FAILURE_SOLID_MODEL
- MAT_221 MAT_ORTHOTROPIC_SIMPLIFIED_DAMAGE

The LS-DYNA analysis type (system C in the [figure above \(p. 45\)](#)) creates an LS-DYNA model (.k file) from the Mechanical model, including lay-up definitions from ACP, and runs the LS-DYNA solver in the background. LS-DYNA features which are not available in Workbench can be added to the model through LS PrePost by doing the following: Export the LS-DYNA input file (use the **Write Input File** Tool in Mechanical, as shown below) and load it in LS PrePost to further preprocess the model. An alternative is to use the **Commands** object and the **Input File Include** constraint. For more details, see [How to use LS-DYNA in Workbench in the LS-DYNA User's Guide](#).

Figure 1.37: Create an LS-DYNA Keyword (.k) File from the Workbench Model within Mechanical

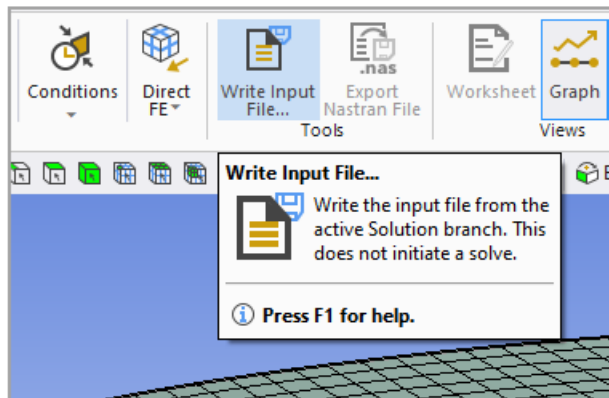

Note:

Not all material cards can be used for layered shells or solids. Here are some of the limitations. Refer to the [LS-DYNA documentation](#) carefully for all details.

- MAT_002/ MAT_ORTHOTROPIC_ELASTIC

Cannot be used with angles other than 0 on integration points. Not valid in general for ACP to LS-DYNA.

Note: This material does not support specification of a material angle, β_1 , for each through-thickness integration point of a shell.

- MAT_221/MAT_ORTHOTROPIC_SIMPLIFIED_DAMAGE

Only valid for 3D_Solid Elements. Not valid in general for ACP to LS-DYNA.

- MAT_059/MAT_COMPOSITE_FAILURE_{OPTION}_MODEL, Option=SHELL/SOLID

Cannot be used with TSHELL. So, valid for ACP to LS-DYNA shell models only.

1.4.4. Multiple Load Cases and Analyses

Complex workflows with multiple load cases and/or analyses are defined in the same way as standard analyses. In most of the cases, the links to share the data are set automatically by the Workbench application. Some links must be manually added. In the following example, the links from the **Setup** cell of the ACP (Pre) system to the **Model** cells of the downstream Mechanical systems have been added manually.

Figure 1.38: Multiple Load Cases and Analyses

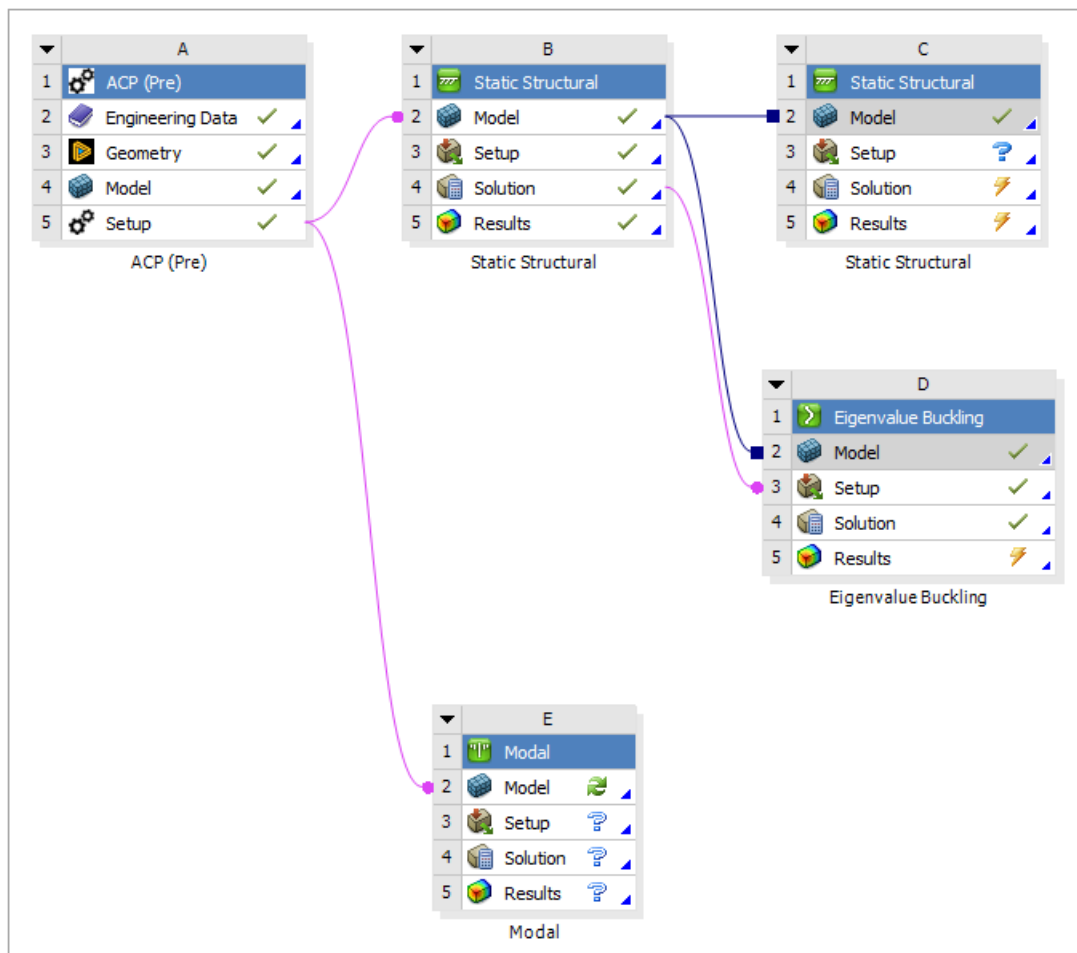

1.4.5. Shared Composite Definition for Different Models

The ACP (Pre) **Setup** cell can be shared across multiple models. This means the same composite lay-up can be applied to models of different geometries and meshes. This functionality can be used in design studies where the composite definition remains the same but different geometries are evaluated.

Submodeling is another situation where this functionality can be used. In a scenario where two models are to share the same ACP (Pre) Setup, one setup cell is dragged on to the other. ACP maps as much information onto the second model as possible. It is advised to use common Named Selections as well as the same **Engineering Data**. The figure below shows an example of a shared ACP (Pre) setup.

Figure 1.39: Two Analyses Share the Same ACP (Pre) Setup

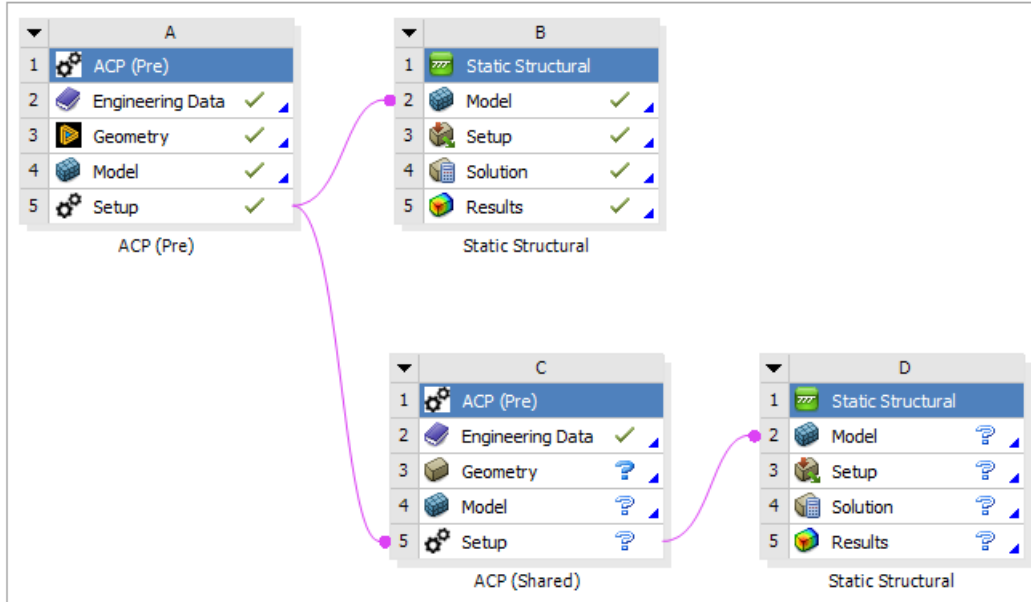

1.4.6. Solid Modeling

Similar to composite shells, composite solids defined using ACP can be imported into Mechanical for analysis by importing the mesh from upstream ACP systems and synthesizing the geometry from the imported meshes. The import of a composite solid from ACP into Mechanical follows the same procedure for shells except that the transfer option **Transfer Solid Composite Data** must be selected as shown below.

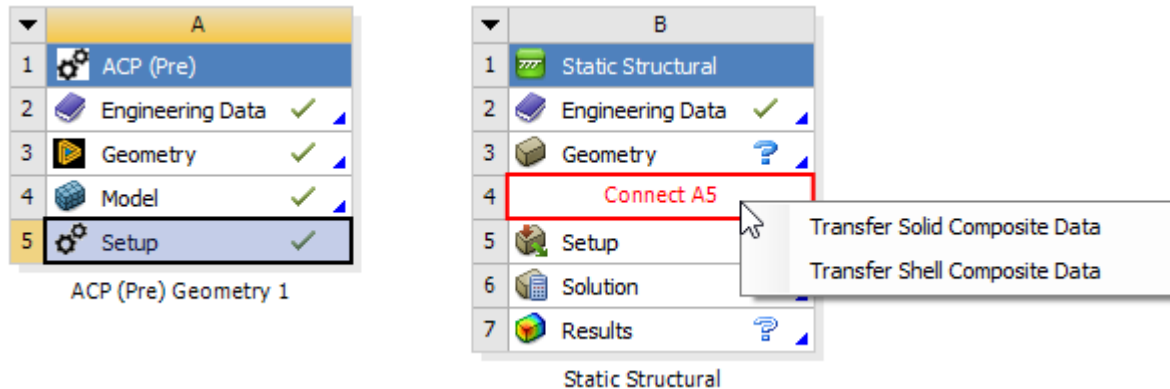

ACP distinguishes between two different approaches: the first approach is an extrusion algorithm that generates a solid mesh based on the Composite Definitions and the shell reference surface. This feature is simply called **Solid Model** (p. 183). In this scenario the solid mesh is completely generated

by ACP (Pre). For more information, refer to the [Guide of Solid Modeling \(p. 283\)](#) and the [Analysis of a Composite Solid Model \(p. 314\)](#) sections of the Help.

In the second approach, the Composite Definitions are mapped onto an external solid mesh that is loaded in ACP. This feature is called [Imported Solid Model \(p. 208\)](#).

Load an External Solid Mesh in ACP (Pre)

External solid meshes can be transferred to ACP (Pre) by linking a **Mechanical Model** component to **ACP Setup** as shown in the Figure below. This allows you to map the composite definitions onto the [Imported Solid Model \(p. 208\)](#).

Figure 1.40: Import Volume Mesh from Mechanical Model (E4 to C5)

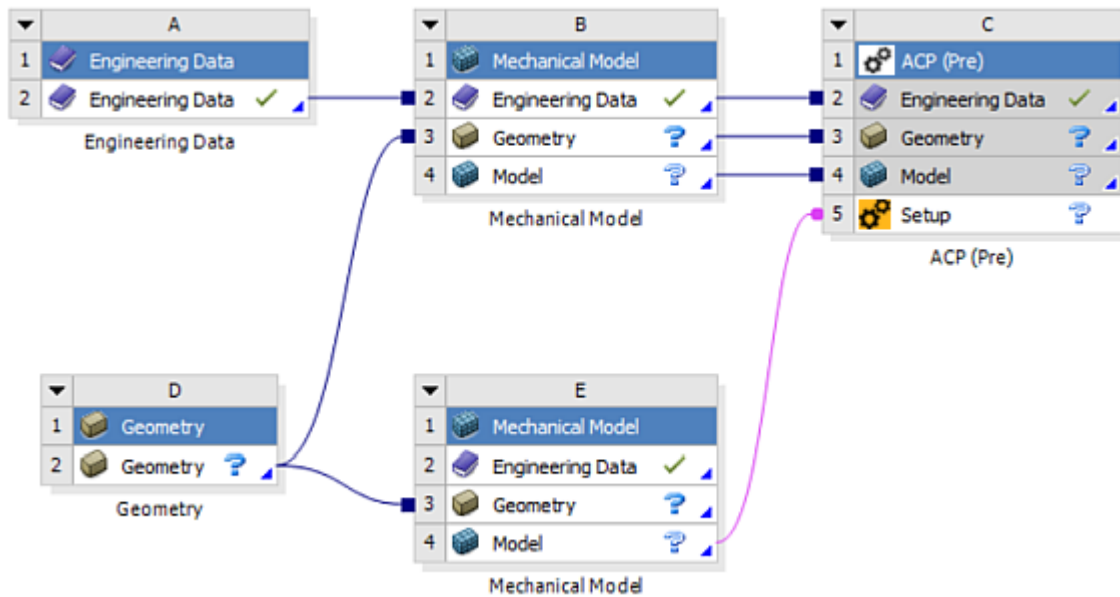

Solid meshes from third party applications can also be loaded into ACP (Pre). In that scenario the mesh is loaded via External Model and Mechanical Model as shown in the next figure.

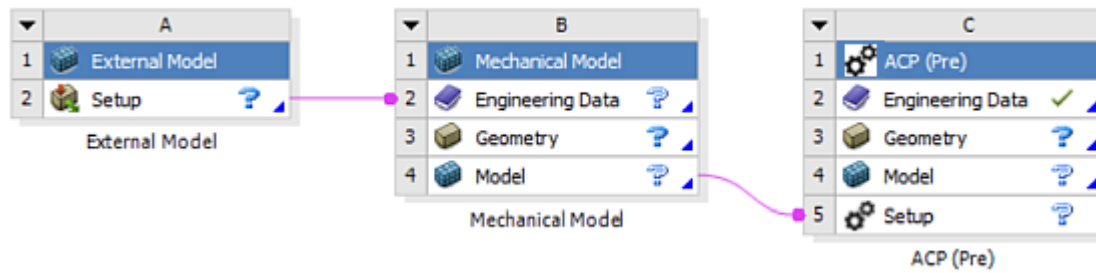
Figure 1.41: Import Volume Mesh from Third Party Application**Note:**

The internal link between the **MechanicalModel** and **ACP Setup** within an **ACP (Pre) System** (C4 to C5 in the figure above) transfers the shell mesh only.

1.4.7. Assembly

You can import meshes from multiple systems into Mechanical. It is possible to combine composite shell, composite solid, and non-layered shell and solid meshes to perform a mixed analysis. Mechanical does not allow the overlap of node/element numbers from multiple systems. The import fails if the mesh node/element numbers from different systems overlap. Meshes from upstream to downstream Mechanical models are renumbered automatically to avoid overlapping. For every analysis system (mesh), you have the choice between automatic renumbering (default) and manual configuration. (See [Renumbering and Transfer Type](#) (p. 51).) If automatic renumbering is disabled, you must ensure that the element/node numbering is unique for each mesh.

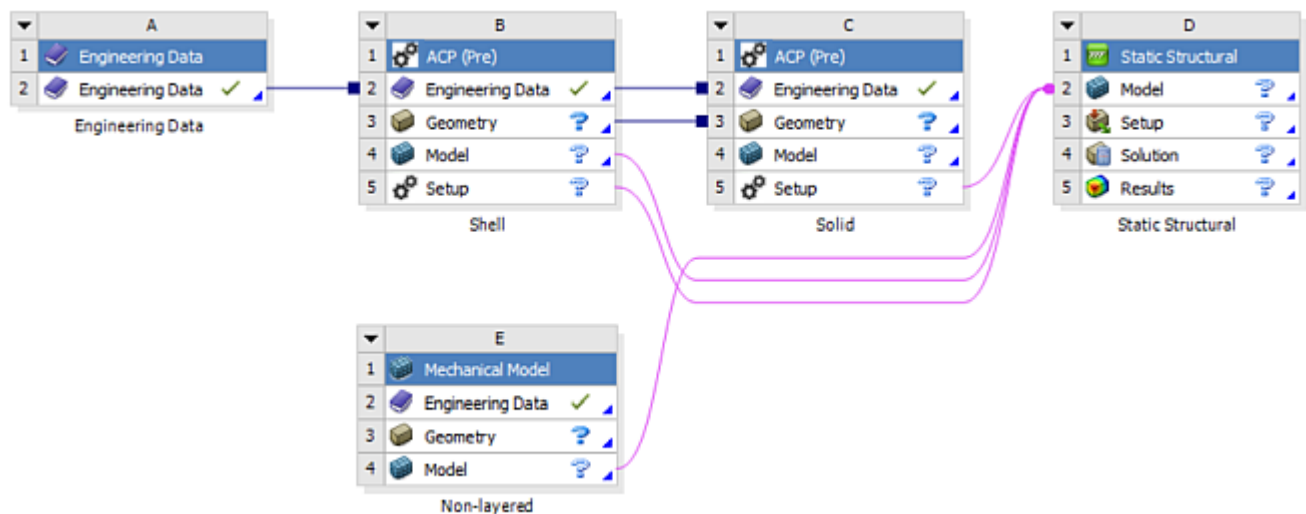
Figure 1.42: A Multi-System Analysis in Workbench

Additional topics in this section:

[1.4.7.1. Renumbering and Transfer Type](#)

[1.4.7.2. Creating a Mixed Assembly](#)

1.4.7.1. Renumbering and Transfer Type

The **Properties** menu of the Mechanical Model allows you to turn automatic renumbering on or off and also to change the **Transfer Type** of **ACP (Pre)** systems from shell to solid.

Properties of Schematic D2: Model		
	A	B
1	Property	Value
2	[-] General	
3	Component ID	Model 1
4	Directory Name	SYS-1
5	[-] Notes	
6	Notes	
7	[-] Used Licenses	
8	Last Update Used Licenses	ANSYS Multiphysics
9	[-] System Information	
10	Physics	Structural
11	Analysis	Static Structural
12	Solver	Mechanical APDL
13	[-] Mesh	
14	Save Mesh Data In Separate File	<input type="checkbox"/>
15	[-] General Model Assembly Properties	
16	Length Unit	m
17	Object Renaming	Based on System Name
18	Group Objects By Source	<input checked="" type="checkbox"/>
19	[-] Transfer Settings for non-layered (Component ID: Model 5)	
20	Number of Copies	0
21	Renumber Mesh Nodes and Elements Automatically	<input checked="" type="checkbox"/>
22	[+] Rigid Transform	
29	[-] Transfer Settings for Shell (Component ID: Setup 3)	
30	Renumber Mesh Nodes and Elements Automatically	<input checked="" type="checkbox"/>
31	Transfer Type	Shell
32	[-] Transfer Settings for Solid (Component ID: Setup)	
33	Renumber Mesh Nodes and Elements Automatically	<input checked="" type="checkbox"/>
34	Transfer Type	Solid

1.4.7.2. Creating a Mixed Assembly

To create a mixed assembly:

1. From the **Analysis Systems** panel, drag and drop an **ACP (Pre) Analysis** system into the project schematic.
2. Drag and drop a supported **Mechanical** system into the **Project Schematic** and create a link from the ACP (Pre) **Setup** cell to the Mechanical **Model** cell.
3. Add other **ACP (Pre)** systems as needed.
4. Drag and drop a **Mechanical Model** component into the **Project Schematic** for the non-layered parts. Create a transfer link from the **Model** cell of the upstream system to the **Model** cell of any downstream systems.
5. Double-click the downstream **Model** cell to edit the model. For every upstream mesh, a **Geometry, Imported Plies, and Named Selections** folder are inserted in the Tree View of Mechanical.

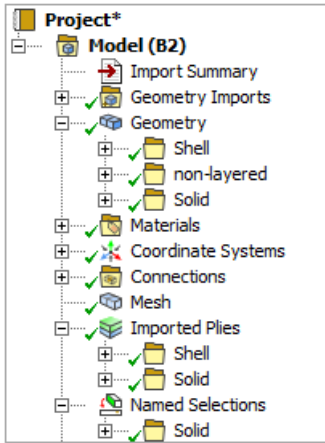

6. Perform all the steps to fully define and solve the **Mechanical Analysis** system.

1.4.8. Limitations

- A connection from an upstream ACP (Pre) **Setup** or Mechanical **Model** cell is only possible if the **Engineering Data** cell of the intended downstream Mechanical system is not modified. If the **Engineering Data** cell of the downstream system is modified by creating/modifying an existing material in the **Engineering Data** interface, a data transfer cannot be created.
- ACP composite definitions are not supported in nested assemblies as shown below. For instance, the Imported Plies of **System B** are not passed to **System C**, and therefore the ply definitions are lost.

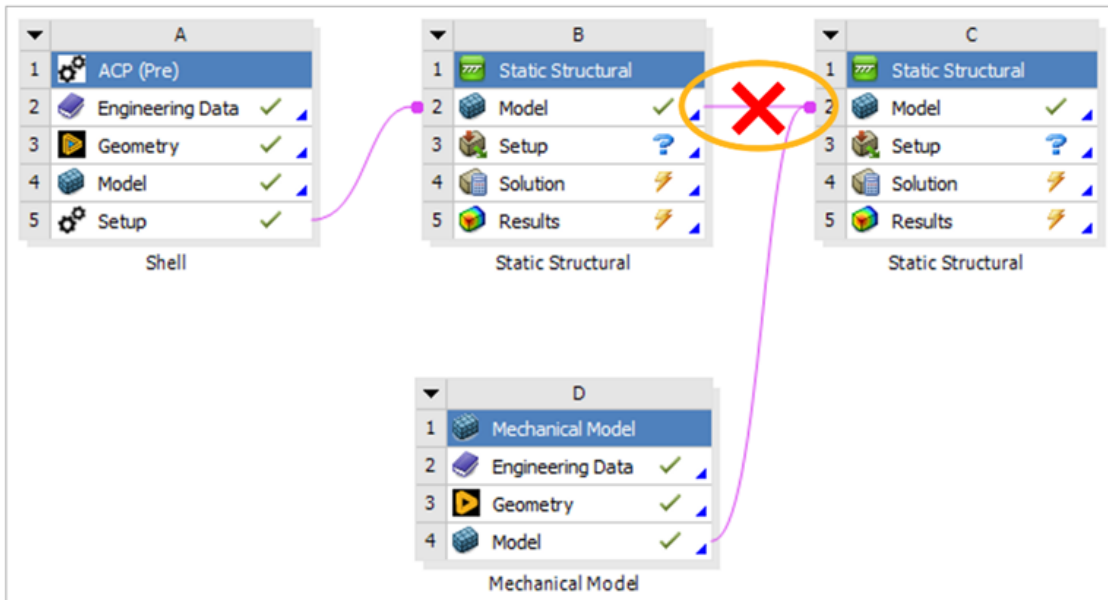

1.5. Migrating ACP Projects from Previous Versions

General Updates

In Version 2019 R2, the coordinate system naming is maintained between Mechanical and ACP. When migrating Workbench archives from previous versions, minor manual input may be required to maintain Rosette reference links. See [Known Limitations \(p. 3\)](#) for more information.

A new serialization format for ACP was introduced in Version 2019 R1 in order to improve performance and usability. Therefore, any ACP database created with version 19.2 or older must be upgraded. The sections below describe how to upgrade ACP projects from previous versions:

ACP into Workbench

When opening ACP projects generated in a previous version, you should perform a Clear Generated Data on the ACP (Pre) Setup cell.

Upgrading Projects from Version 17.1 or Older

Projects older than version 17.2 should be opened and saved in any version from 17.2 to 19.2 to ensure a robust upgrade to the current release. Please ensure that every ACP-Pre, -Shared, and -Post system is completely updated and saved. This intermediate upgrade is supported starting from version 14.0.

Upgrading Projects from Versions 17.2 to 19.2 to the Current Release

If you open or restore a Workbench project that has been created with any version from 17.2 to 19.2, then the ACP systems turn to a `refresh required` state. This ensures that the upgrade happens automatically on refresh or update of the ACP systems. This also leads to the situation that Shared systems cannot be launched before the corresponding (upstream) ACP-Pre system has been updated. Once the upgrade is done, up-to-date status, etc. are maintained.

Miscellaneous

Version 17.0 introduced a new workflow for ACP (composites). The existing workflow from previous versions is still valid. If you wish to upgrade your projects from previous versions to the new composite workflow, please contact your technical support representative.

ACP Standalone

Upgrading ACP Databases from Version 17.1 or Older

ACP databases older than version 17.2 should be opened and saved in any version from 17.2 to 19.2 to ensure a robust upgrade to the current release.

Upgrading ACP Databases from Versions 17.2 to 19.2 to the Current Release

ACP models that have been generated with any version from 17.2 to 19.2 can be upgraded easily. Open the `.acp` file in the current release and perform a `Save As` in order to generate the new `.acph5` database file.

Python UI

Version 18.0 changed the material scripting interface for ACP. A material's properties (for example engineering constants and stress and strain limits) are no longer members of the Material class, but each property forms its own class instance of the type PropertySet. This is to better reflect the individually closed data basis for data interpolation in case the properties depend on user-defined field variables (see [Variable Material Data in Composite Analyses \(p. 303\)](#)). The PropertySet instances can be accessed by their string key on the Material class. ACP scripts using materials must be updated to be compatible with the new material properties.

In 2019 R1, The model attribute `create_cad_selection_rule()` has been replaced with `create_geometrical_selection_rule(geometrical_rule_type='geometry')`. Scripts that used the CAD Selection Rule in previous versions need to be adapted accordingly for this release.

ACP (Post) to Mechanical Software Migration

The ACP (Post) system is now retired and removed from the ACP application. Ansys recommends using the Mechanical software to postprocess composite simulations. This optimizes workflows since the postprocessing is done in the same Mechanical system.

Starting from Release 25 R1, the Ansys documentation reflects composite postprocessing in Mechanical software. This section covers:

- [Link to Composite Postprocessing in the Mechanical Software](#)
- [ACP \(Post\) Migration Tool](#)
- [PyDPF Composites](#)

Composite Postprocessing in the Mechanical Software

For thorough information on composite postprocessing in the Mechanical software, see [Composite Postprocessing in the Mechanical User's Guide](#).

ACP (Post) Migration Tool

ACP (Post) has a migration tool available to help migrate failure criteria definitions to the Mechanical software.

Migrate a failure criteria definition from ACP (Post) to the Mechanical software through the following steps:

1. In the current release's software, open the Workbench project that you want to migrate. Then, start ACP (Post).
2. In ACP (Post), go to the **Tools** tab and select the **Migration Helper...** cell from context menu.

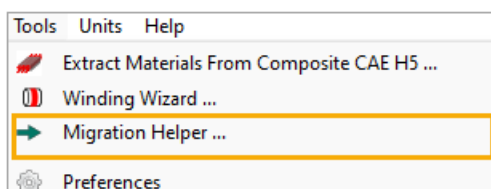

- Click the **Save to File** button and choose a file to store the migration script in.

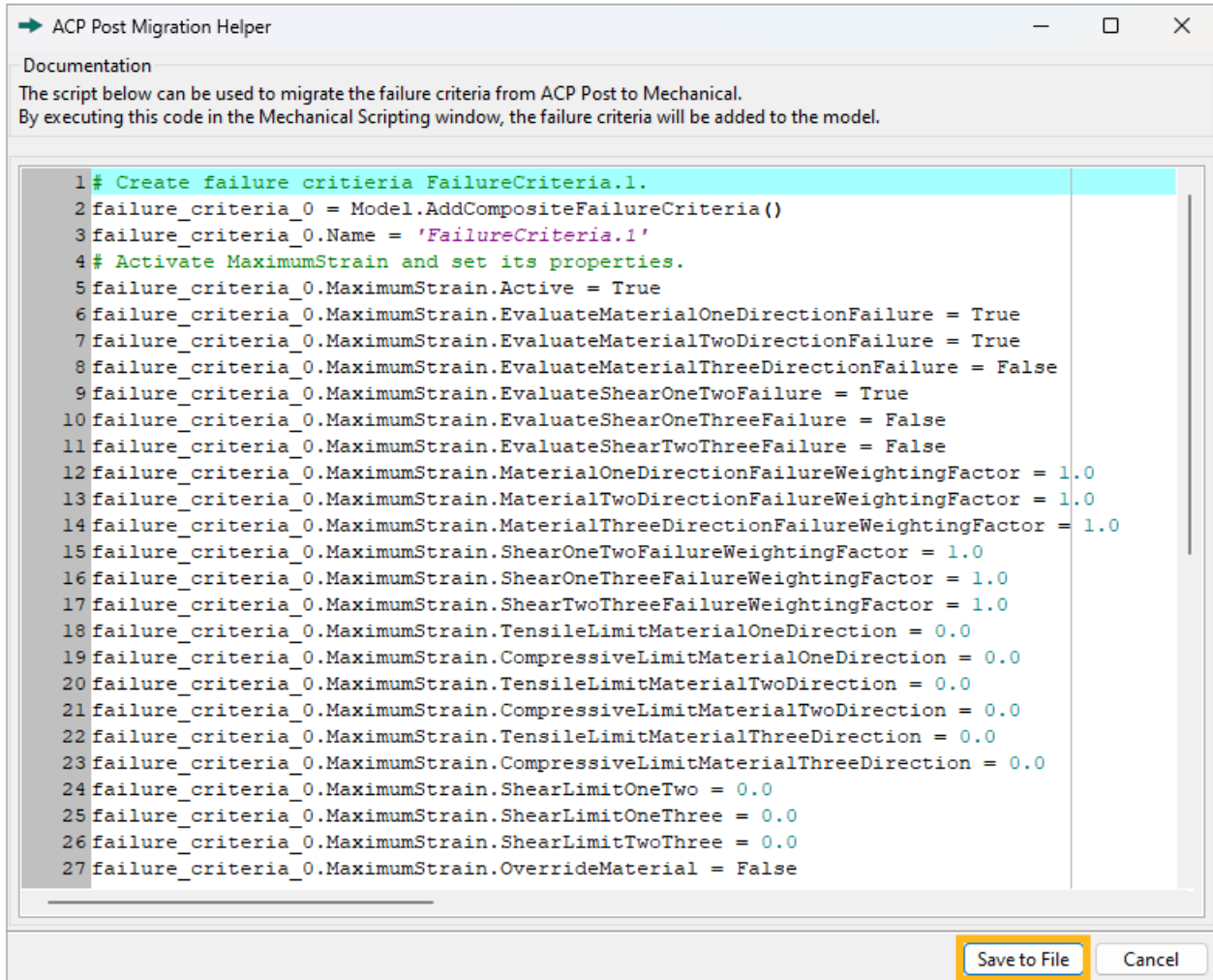

- In the Mechanical software, from the **Automation** tab, click the **Scripting** icon to show the Mechanical scripting view.

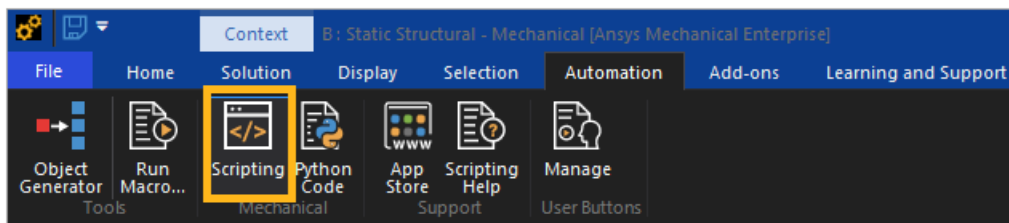

- In the Mechanical scripting view, click the **Open Script** icon and select the previously saved file.

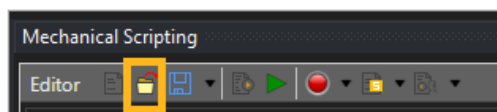

- Click the **Run Script** icon to create the failure criteria in the Mechanical software.



- Once the migration is complete, delete the ACP (Post) system in the Workbench application.

You can repeat steps 3 to 7 for each instance where the failure criteria definition must be imported to the Mechanical software.

Starting from Release 2024 R2, the **Run Script** feature uses failure criteria scripting capabilities in the Mechanical software. For more information on these capabilities, see [Ansys.ACT.Automation.Mechanical.Results.CompositeFailureResults Namespace in the ACT API Reference Guide](#).

PyDPF Composites

You can also postprocess composite structures using the PyDPF Composites Python module. For more information, see the documentation.

1.6. The ACP Python Scripting User Interface

The ACP Python Module provides the scripting user interface of ACP. This scripting interface provides programmable control of the ACP application. You can build complete ACP models from scratch, facilitating the creation of comprehensive ACP models directly from external data sources. You can also use scripting for parameter studies and building complex lay-ups apart from the ACP GUI.

For documentation on the ACP scripting interface, including its object tree and classes, see [ACP scripting interface 2024 R2](#) in the Ansys Developer Portal.

1.7. Stand Alone Operation

ACP can be used as a Stand Alone application. This section describes how ACP can be operated in Stand Alone mode. It is important to know that the Stand Alone mode does not support all features that are available within Workbench (For instance, the user fields and variable materials are not supported.)

Version 2019 R1 introduced a new serialization format. This changes the handling of external sources (shell input mesh or CAD geometries) when ACP is run in standalone mode. Modifications of the input files are no longer automatically detected by ACP and are not considered on update or open. Therefore, you must refresh the inputs explicitly:

- Reference Surface (shell): perform a **Reload** of the model (**Model> Reload**)
- CAD Geometry: press **Refresh** button in the property dialog of the object
- Imported Solid Model (solid mesh): press **Refresh** button in the property dialog of the object

1.7.1. Starting ACP in Windows

1.7.2. Starting ACP in Linux

1.7.3. Command Line Options and Batch Mode

1.7.4. Workflow in Stand Alone Operation

1.7.1. Starting ACP in Windows

To start ACP in Stand Alone mode in Windows, use the shortcut in the Start Menu. The shortcut can be found in **Programs\ANSYS 2025 R1\ACP**

1.7.2. Starting ACP in Linux

On a standard installation, ACP can then be started by entering the following command into the command prompt:

```
/ansys_inc/v251/ACP/ACP.sh
```

Command line options listed in [Command Line Options and Batch Mode \(p. 57\)](#) are also valid in Linux.

1.7.3. Command Line Options and Batch Mode

ACP can also be used on a command line level. The general usage of the ACP start script is:

```
ACP.exe [options] [FILE]
```

The supported command line options are:

Long Form	Short Form	Description
--version		Display the program's version number and exit.
--help	-h	Display the program's command line options and exit.
--batch=BATCH_MODE	-b BATCH_MODE	Run the ACP program in Batch Mode. 0 - Batch Mode disabled. 1 - True Batch Mode. (No GUI will be created. Snapshot functionality is not supported.) 2 - Batch Mode with GUI toolkit but hidden window. (Snapshot functionality is supported.)
--debug	-d	Enable debug output.
--num-threads=NUM_THREADS	-t NUM_THREADS	Number of threads to be used. 0 for max available threads.
--logfile=LOGFILE	-o LOGFILE	Specify file to be used for log messages.
--mode=MODE	-m MODE	Application starts up in the specified mode ('pre' or 'shared').
--workbench	-w	Run the ACP application in Workbench mode.
--port=PORT	-p PORT	Specify port number for remote access server.
[FILE]	[FILE]	If the specified file is an ACP project, it is opened. If it is a Python script it is executed.

1.7.4. Workflow in Stand Alone Operation

The difference between Stand Alone operation and Workbench Integration is that the several steps or operations have to be performed manually. The following is an overview of these steps:

1. Generate the Ansys input file in the Workbench application or Mechanical APDL, including the loads and boundary conditions (.inp, .dat, or .cdb).

From the Workbench Application:

In the Mechanical application, select the analysis folder. Then, click the **Environment** tab and select **Write Input File** to write a .dat or a .inp file.

Figure 1.43: Write Input File

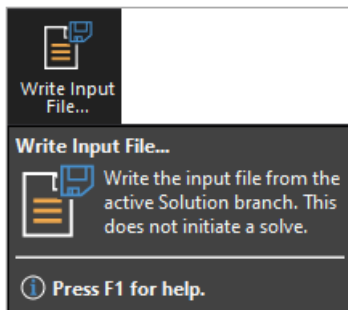

Alternatively, in the project schematic, you can update the **Setup** status. A ds .dat file is written in the project folder SYS-X/MECH. This file can also be used as Preprocessing Model in ACP.

From Mechanical APDL:

In Mechanical APDL, use the command **CDWRITE** to write a .cdb file, which can be used as a preprocessing model in ACP.

```
cdwrite,db,file,cdb
```

2. Start ACP
3. Import the Ansys Model in ACP.

ACP supports the .dat, .inp and .cdb file formats. Import the model into ACP by selecting **File > Import Model** or by right-clicking the **Models** object in the Tree View and selecting **Import Model**.

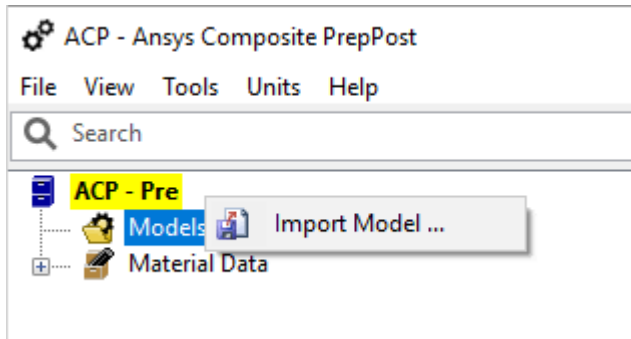
Figure 1.44: Import Ansys Model Using the Context Menu

4. Define the Materials, or copy the materials from the ACP Material Databank.
 For more information on defining materials, see [Material Data \(p. 74\)](#).
 For more information on using the Material Databank, see [Material Database \(p. 244\)](#).
5. Create laminate sequences.
 See [Usage Reference \(p. 61\)](#) and [Composite Modeling Techniques \(p. 261\)](#) for detailed information.
6. Update the model after any change in the ACP definition (lay-up definitions) or change of the input model.
 After any modification in the input model, the input file must be reloaded (see [Model \(p. 62\)](#)).
 After any change in the ACP definition, the database must be updated. Use the [Update \(p. 24\)](#) button in the toolbar.
7. Send the model to the Ansys solver (**Solve Current Model**) or export the new analysis file (**Save Analysis Model**). For more information, see [Model \(p. 62\)](#).
8. Perform composite postprocessing.
 Use the Mechanical application or for postprocessing.
9. Save the ACP (Pre) composite definitions.
 Use the **File** menu or right-click the **Models** object in the Tree View to use the contextual menu.

1.8. Tutorials and Examples

The [Tutorials](#) describe the basic features of ACP and provide a quick start to the software. The [Example Analyses \(p. 307\)](#) describe special workflows. You must be familiar with the basics of the software to understand the examples.

Chapter 2: Usage Reference

This chapter consists of the following sections:

- 2.1. Features
- 2.2. Exchanging Composite Definitions with Other Programs

2.1. Features

The features described are in the following sections:

- 2.1.1. Model
- 2.1.2. Scripts
- 2.1.3. Material Data
- 2.1.4. Element and Edge Sets
- 2.1.5. Geometry
- 2.1.6. Rosettes
- 2.1.7. Look-Up Tables
- 2.1.8. Selection Rules
- 2.1.9. Oriented Selection Sets (OSS)
- 2.1.10. Modeling Groups
- 2.1.11. Imported Modeling Group
- 2.1.12. Field Definitions
- 2.1.13. Sampling Points
- 2.1.14. Section Cuts
- 2.1.15. Sensors
- 2.1.16. Solid Models
- 2.1.17. Lay-Up Plots
- 2.1.18. Scenes
- 2.1.19. Views
- 2.1.20. Ply Books
- 2.1.21. Parameters
- 2.1.22. Material Database

2.1.1. Model

Right-click the context menu of the model for access to model properties, save options, and import/export interface options. The context menu options are different when ACP is run in Workbench compared to Stand-Alone Mode.

In Workbench mode, these options are:

Figure 2.1: Model Context Menu in Workbench Mode

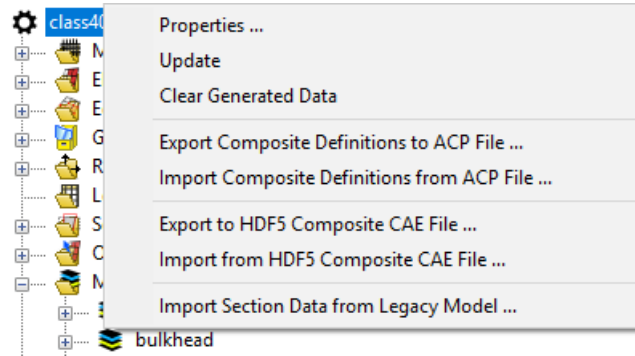

In Stand-Alone mode, the options are:

Figure 2.2: Model Context Menu in Stand-Alone Mode

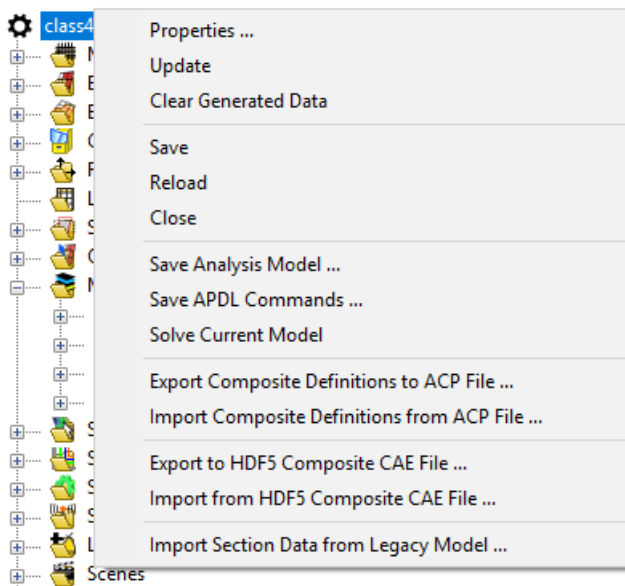

This is an overview of the items in the model context menu. Selected items are explained in more detail below.

- **Properties:** Display the **Model Properties** dialog where information about the model, input file, tolerances and unit system can be found and modified (see [Model Properties - General \(p. 63\)](#))
- **Update:** Update the entire model.
- **Clear Generated Data:** Delete all results of the previous update and remove the serialized cached data.

- **Save** (Stand Alone only): Save the selected model.
- **Reload** (Stand Alone only): Reload the input file into the database (return to the last saved state).
- **Close** (Stand Alone only): Close the selected model.
- **Save Analysis Model** (Stand Alone only): Save the Ansys input file including the lay-up defined in ACP.
- **Save APDL Commands** (Stand Alone only): Save the lay-up definition as APDL Command Macro, modifies the model from isotropic material monolithic elements to orthotropic layered composite elements with some adjustments on results save.
- **Solve Current Model** (Stand Alone only): Submit the Ansys input file including the composite lay-up definition to the Ansys solver.
- **Export Composite Definitions to ACP File:** Export the lay-up definitions to a different ACP file (see [Import/Export of ACP Composite Definitions File \(p. 67\)](#)).
- **Import Composite Definitions from ACP File:** Import the lay-up definitions from an other ACP file (see [Import/Export of ACP Composite Definitions File \(p. 67\)](#)).
- **Export to HDF5 Composite CAE File:** Export the mesh with the Composite Definitions to a .HDF5 file (see [Import From/Export to HDF5 Composite CAE File \(p. 68\)](#)).
- **Import from HDF5 Composite CAE File:** Import a mesh with Composite Definitions from a .HDF5 file (see [Import From/Export to HDF5 Composite CAE File \(p. 68\)](#)).
- **Import Section Data from Legacy Model:** Import section data from a Mechanical APDL legacy model (see [Import Section Data from Legacy Model \(p. 68\)](#)).

2.1.1.1. Model Properties - General

The following figures show the **Model Properties** dialog window in both Workbench and Stand Alone mode.

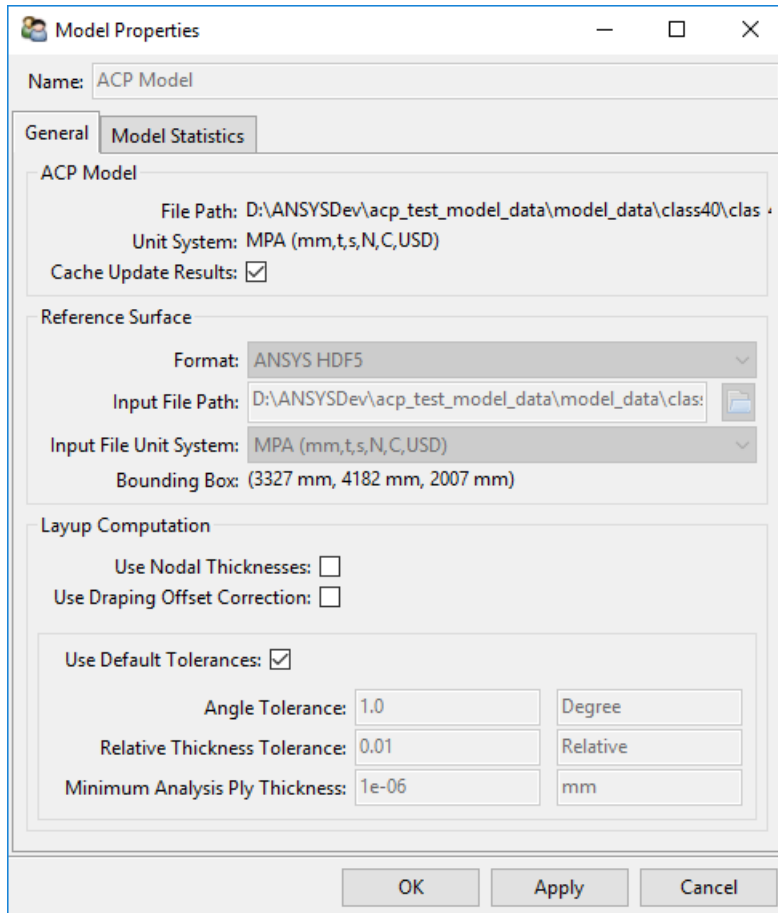
Figure 2.3: General Model Properties

In Stand-Alone mode, the **Format**, **Input File Path**, and **Input File Unit System** properties become editable and are used to import the shell reference surface (shell mesh). The **Model Statistics** tab gives an overview of model statistics including number of materials, stack-ups, etc. The full list of Model Statistics are shown in [Figure 2.4: Model Statistics \(p. 64\)](#) below.

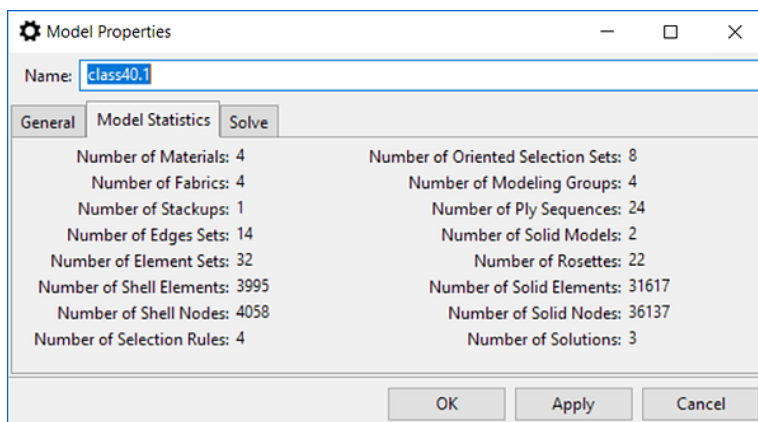
Figure 2.4: Model Statistics

2.1.1.1.1. ACP Model

The **ACP Model** section of the **Model Properties** dialog displays the path to the ACP model file. The unit system of the ACP model is also displayed. This unit system can be changed in the [Units \(p. 20\)](#) menu. The selected unit system is displayed in the status bar at the bottom of the ACP window.

The property **Cache Update Results** controls whether the update results (i.e ply extents, analysis plies, solid models) are stored. This allows you to reopen the most recently used lay-up model state and improves the application's performance. You can disable this feature in order to reduce the size of the .ACPH5results file. Note, if the feature is disabled, you will be prompted for a model update whenever the ACP Model is reopened.

2.1.1.1.2. Reference Surface

The file path to the input file of the reference surface is set in the **Reference Surface** section of the **Model Properties** dialog.

In Workbench, the reference surface is automatically transferred to ACP in the Ansys HDF format. In this case, the reference surface unit system is fixed.

In Stand Alone mode, the input file path for the reference surface is set here. The input file can be a .DAT (generated by Workbench), .INP, or .CDB (generated by Mechanical APDL with **CDWRITE**). The unit system for the reference surface can be set if it is not defined in the input file.

The unit system must be defined in Stand Alone mode when importing or exporting a model in .HDF5 format and also when exchanging material data with the database or ESAComp.

The bounding box describes the dimensions of the reference surface in xyz-space.

2.1.1.1.3. Lay-Up Computation

The options defined in this section are described below:

Angle and Relative Thickness Tolerance

ACP transfers the Composite Definitions into Section Data so that they can be interpreted by Ansys Mechanical. In the case of curved surfaces or draped laminates, sections may change continuously with every element as their orientations change. This generates information which can reduce the performance of data transfers and solvers. To avoid this, ACP groups section data of multiple elements together within a certain tolerance range.

The **Angle Tolerance** field sets the allowable ply angle tolerance between the same layers of neighboring elements. The **Relative Thickness Tolerance** field applies to the individual layer thickness as well as the global lay-up thickness. For two elements to be included in the same section definition, the difference of the angle and the relative thickness of every ply must be within the defined tolerance. Core materials are typically thicker than a laminate by a factor of 10 or more. As such, the thickness tolerance is defined as a relative rather than an absolute value. The default tolerance values are very small compared to the manufacturing tolerances of composites. The loss of accuracy is negligible.

Minimum Analysis Ply Thickness

Cutting operations used in ACP can cut an analysis ply to a thickness thinner than the specified ply thickness. For example, if a Cut-Off geometry intersects a ply at its vertical mid-point, it will slice the ply in half. When the intersection occurs at ply boundaries, an extremely thin layer can appear as the result of geometric tolerances of CAD files. These extremely thin layers are of the order of magnitude of 10^9 and are purely the results of numerical imprecision. The **Minimum Analysis Ply Thickness** field sets a thickness threshold below which no such plies can arise.

The global default values for the above mentioned tolerances and thickness are set in the [Section Generation \(p. 20\)](#) dialog but can be overridden in the **Model Properties** dialog.

Use Nodal Thicknesses

ACP supports ply with [variable thickness \(p. 273\)](#) and [Ply Tapering \(p. 269\)](#). By default, the thicknesses are evaluated at the element centers, but for Ply Tapering and Cut-Off operations, and plies with variable thicknesses, it can be worthwhile to evaluate them on a per-node basis. This additional data further refines the lay-up representation in ACP and is used in shell and solid model analysis. The option **Use Nodal Thicknesses** enables the node-based thicknesses evaluation. For more information, see [Element- vs. Node-based Thicknesses \(p. 68\)](#).

Use Draping Offset Correction

By default, during draping simulation, the application lays the draping mesh on the reference surface of the model independently of the lay-up thickness. However, for thick laminates, such as sandwich structures, with Ply Tapering and Drop-Offs, this approach can lead to inaccurate results. If you enable the Use Draping Offset Correction option, the draping mesh follows the bottom offset (relative to the reference surface orientation) of the selected ply. This allows the application to account for the lay-up thickness and, as a result, provides a more accurate draping simulation. Enabling offset correction for thick and curved laminates also improves the precision of the boundary and area for the flat wrap of the ply.

2.1.1.1.4. Model Summary

Global information about the model is displayed in this section of the dialog. The **Number of Elements** field includes both layered shell and layered solid elements.

2.1.1.2. Solve

In Stand Alone, mode the **Model Properties** dialog has a second tab: **Solve**. On it, you can define the file path of the analysis model and the working directory used by the solver. The **Solver Status** and the **Output File** information are also located on the **Solver** tab. In the case of an incomplete run, warning and error messages from the solver can be found here.

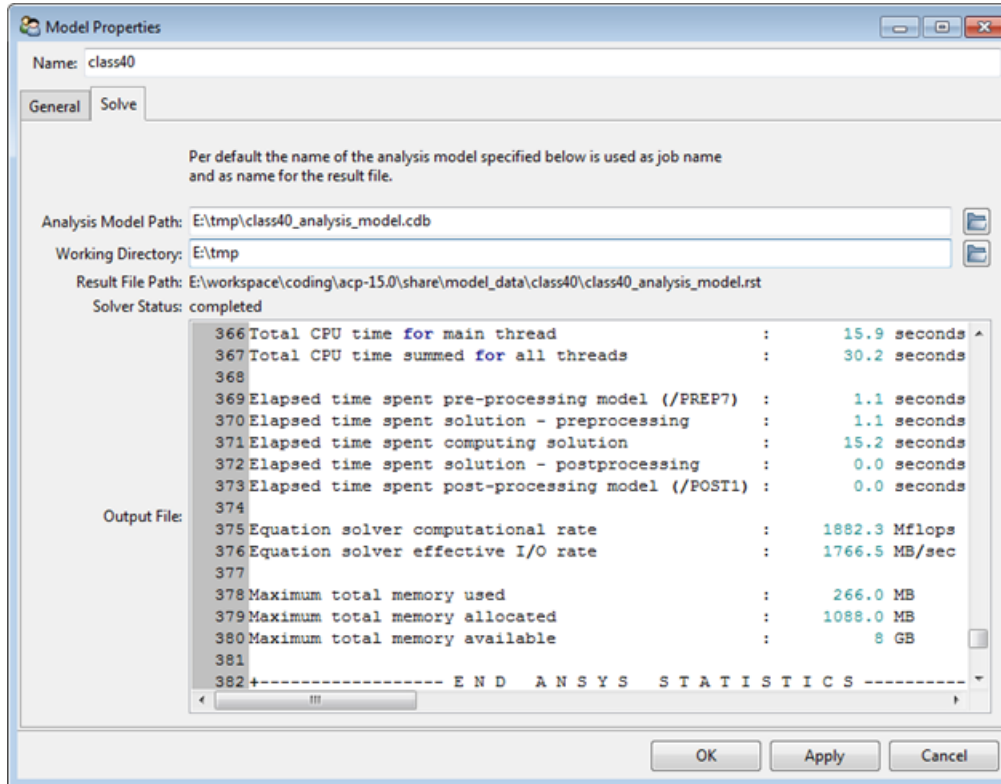
Figure 2.5: Solver Information (Solve.out)

2.1.1.3. Import/Export of ACP Composite Definitions File

The ACP Composite Definitions file contains all the information stored in an ACP model. The model is defined in the ACP file in the ACP Python scripting language. During import, you will be asked specify how ACP should handle objects having the same name.

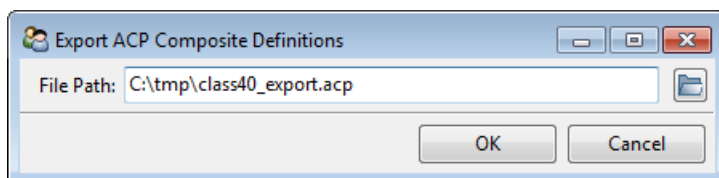
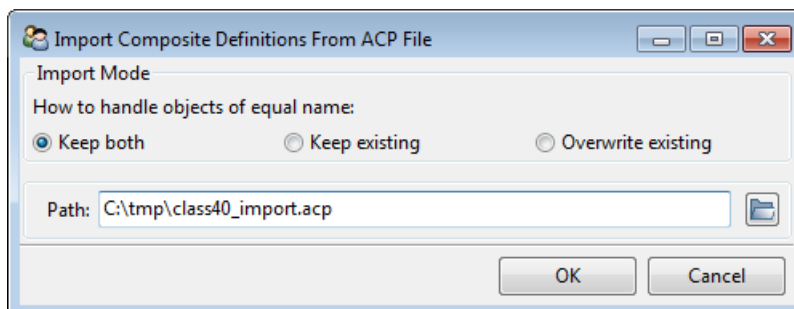
Figure 2.6: Export Composite Definitions Window**Figure 2.7: Import Composite Definitions Window**

2.1.1.4. Import From/Export to HDF5 Composite CAE File

You can exchange composite models across different CAE and CAD platforms using the HDF5 Composite CAE specification. For more information, see [HDF5 Composite CAE Format \(p. 245\)](#).

2.1.1.5. Import Section Data from Legacy Model

The **Import Section Data from Legacy Model** menu option automatically loads the section data from a legacy Mechanical APDL layered shell model. This option converts the data into standard ACP Composite Definitions. The conversion is based on the element labels, so the meshes of the legacy and ACP model have to be equal. See the [Import of Legacy Mechanical APDL Composite Models \(p. 254\)](#) section for a detailed explanation for importing legacy models.

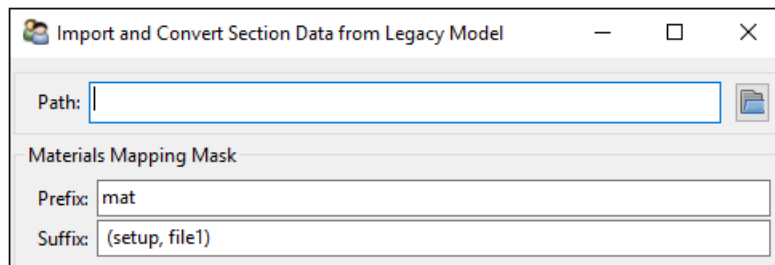

Parameters

The parameters for the menu include:

- **Path:** This is the file path to the legacy file.

The Workbench framework does not allow ACP to add materials to the Workbench project during the import process. Therefore, the materials have to be created and/or imported in an upstream Engineering Data system before you can import the legacy model into ACP. This makes sure that a full transfer of the section-based lay-up of the legacy model is performed. The **External Model** component enables you to import materials easily (see [Import of Legacy Mechanical APDL Composite Models \(p. 254\)](#)). However, the material IDs get converted following a certain pattern. The Material ID pre- and suffix property of the import options allows you to define this pattern. The mapping is case independent.

- **Materials Mapping Mask:** This area of the dialog provides the following entries:
 - **Prefix:** A text-based string displayed before the legacy material ID in Workbench.
 - **Suffix:** A text-based string displayed after the legacy material ID in Workbench.

2.1.1.6. Element- vs. Node-based Thicknesses

By default, ACP stores the thicknesses per ply and element. In other words, the ply's thickness is constant per element. This representation is consistent with the solver capabilities of layered shells, since they do not support varying ply thickness within one element. Therefore, geometry features (for example thickness by geometry or taper edge) calculate the ply thickness at the element centers (element-based thicknesses). ACP also supports node-based thicknesses. When node-based thickness evaluation is enabled, thicknesses are evaluated supplementary to the element-based thicknesses.

This involves some performance losses but gives benefits when working with tapered plies (see [Thickness](#) (p. 146) and [Cut-Off Selection Rules](#) (p. 120)) or ply thicknesses (see [Look-Up Table](#) (p. 275)).

Shell Lay-Up

The differences between element- and node-based thicknesses are best explained with a tapered ply. The nominal ply covers the entire plate and defines the tapering as shown in the figure below. The figure on the left shows the element-based piercing where the computed ply thickness at the element centers is negative for the upper two elements (red arrows). The right image shows the node-based piercing that brings a more precise resolution. In that specific case, all elements have at least one node with a positive (valid) thickness.

Figure 2.8: Element-based vs. Node-based Piercing

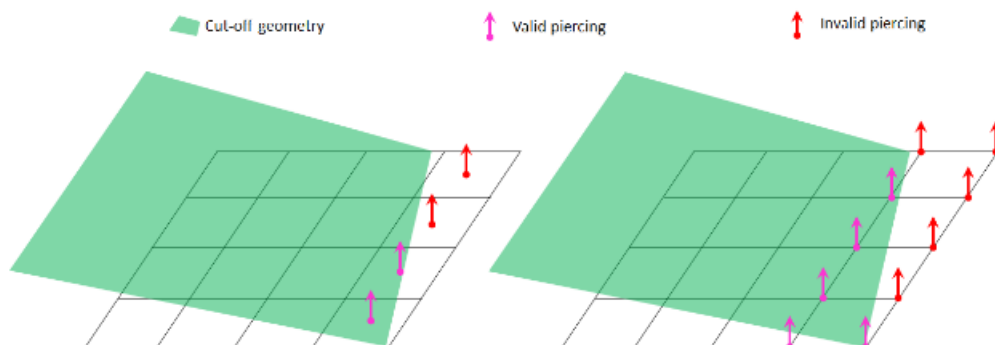

The final result for both options is shown in the following figure. The ply is cropped if the thicknesses are only evaluated at the element corners since two elements have a negative thickness. In contrast, the ply covers the entire plate if the thicknesses are evaluated for each node because at least one node of each element has a valid ply thickness. If the node-based piercing determines that only some nodes of an element have a valid piercing but not the element center, then the thickness at the element center becomes the average node-based thickness.

Figure 2.9: Ply Extension and Element-wise Thicknesses of a Tapered Ply with Element-based (left) and Node-based (right) Thicknesses

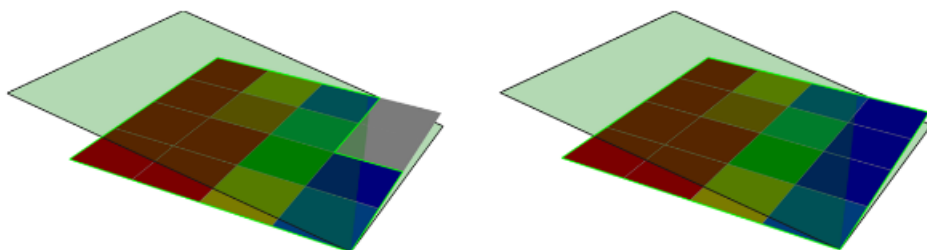

In summary, node-based thicknesses bring some benefit for shell models, but also bring certain restrictions. Node-based thicknesses cannot be evaluated if a ply covers more than two components, as shown in the figure below. In other words, a ply is not allowed to cover three elements that share one edge.

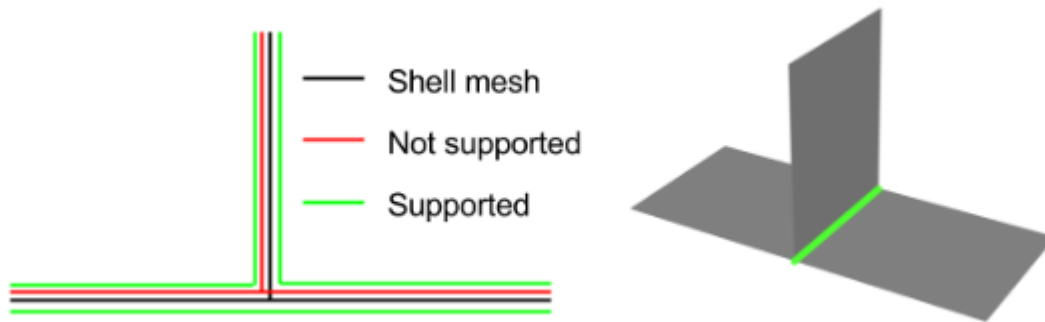
Figure 2.10: Restriction for Node-based Thicknesses**Solid Extrusion**

The usage of node-based thicknesses brings more benefits if you perform a solid model analysis instead of a shell analysis because the extrusion of the solid model is performed on a per-node basis. Additionally, layered solid elements support plies with variable thickness. The figure below shows the solid model from an example discussed in a previous section. As for the shell model, the solid model with element-based thicknesses does not cover the entire reference surface. In contrast, the node-based extrusion represents the ply extension more precisely. Additionally, it also captures the variable ply thickness over one element and therefore reproduces the taper much better.

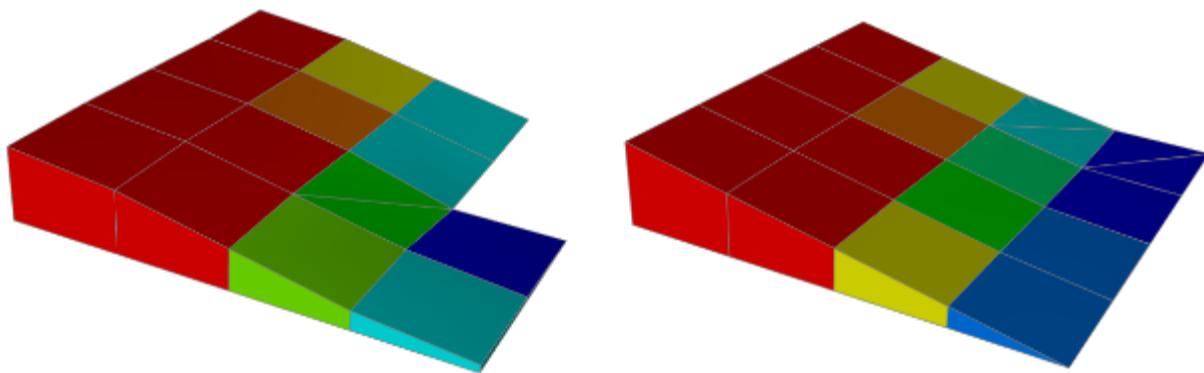
Figure 2.11: Extrusion of a Tapered Ply without and with Node-based Thicknesses on the Left and Right, Respectively

There are two additional examples where you can benefit from node-based thicknesses:

- **Tapered edge:** Only nodal thicknesses can represent tapers with 0 thickness correctly.

Figure 2.12: Solid Model Extrusion of a Tapered Ply without and with Node-based Thicknesses

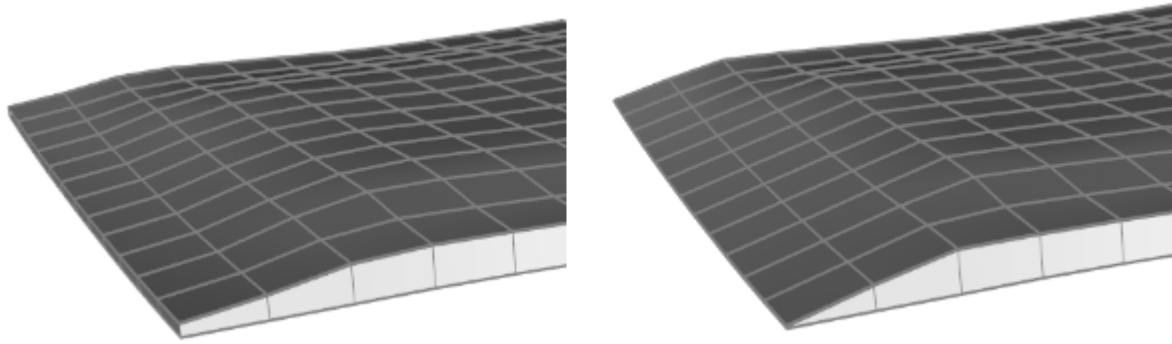

- **Cut-Off selection rules with Ply Tapering:** By default, tapering evaluated at the element centers can cause ripples in the extrusion. Node-based thicknesses result in a smoother shape and more accurate ply representation. In this specific case, it even allows you to proceed without a Snap-To operation, since the surface is of good quality.

Figure 2.13: Cut-Off Selection Rule with Ply Tapering Based on Element-based and Node-based Thicknesses

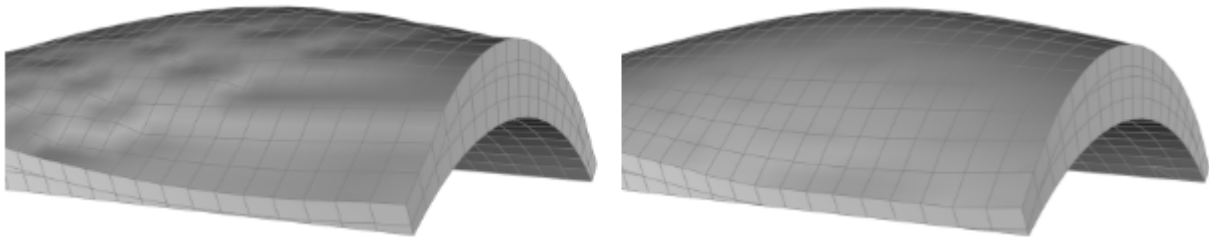

2.1.1.7. Winding Wizard

Refer to the section [Winding Wizard \(p. 14\)](#).

2.1.2. Scripts

Scripts enable more complex parametrization than is possible with [Input Parameters \(p. 241\)](#) alone. You can use scripts to execute arbitrary [Python code \(p. 56\)](#) as part of updating the model. Scripts are marked for execution whenever a parameter or the script itself changes.

To create a script, select **Create Script...** in the context menu of the **Scripts** object in the ACP Tree View.

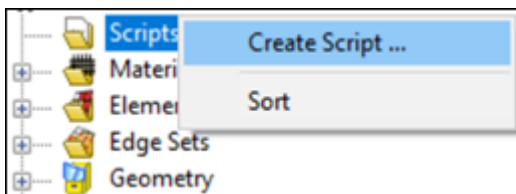

The following sections describe Scripts in detail:

2.1.2.1. Executing Scripts

2.1.2.2. Script Properties

2.1.2.3. Limitations

2.1.2.4. Tips and Best Practices

2.1.2.5. Sorting Scripts

2.1.2.1. Executing Scripts

By default, scripts are marked for execution whenever a parameter or the script itself changes. The **Unbound Input** parameter category is meant for parameters that are used inside a script.

For scripts that should execute with every model update even if no parameters have changed, set the **Update Mode** property to **Always**.

For scripts that should never execute automatically, set the **Update Mode** property to **manual**. These scripts can be run manually either from the properties dialog, or the context menu of the script as shown below.

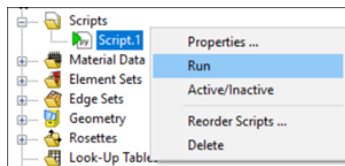

2.1.2.2. Script Properties

You can edit a script and set its execution properties in the **Properties** dialog:

- **Active:** Activates or suppresses the script. Only active scripts can be executed.
- **Update mode:** Determines when the script is executed. Possible options are:
 - **On Triggers:** Execute when updating the model, if a parameter or the script has changed.
 - **Manual:** Execute only when instructed by the user.
 - **Always:** Execute on every model update.
- **Source:** Contains the Python code to be executed.

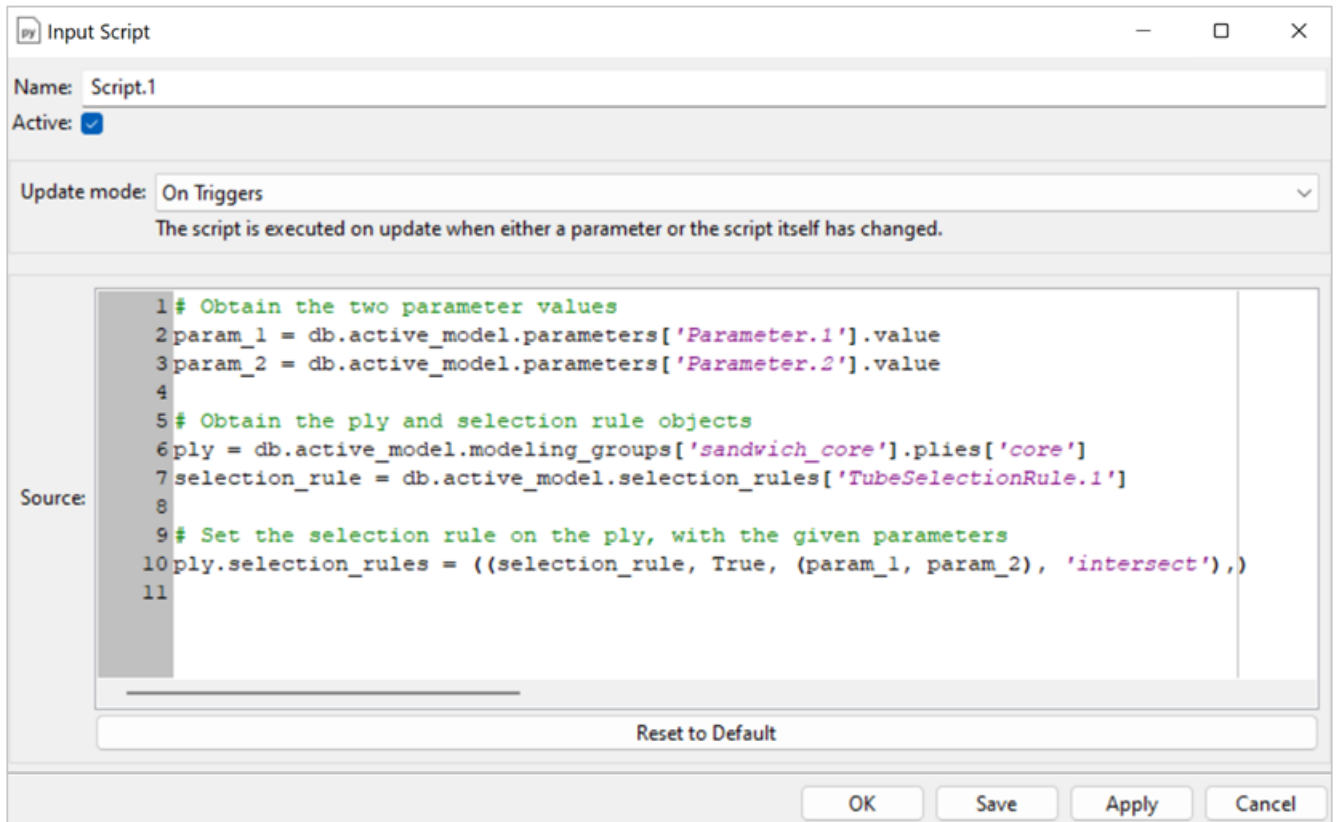

In addition to the default buttons (**OK**, **Apply**, and **Cancel**), the Script has a **Save** button which saves the modifications without closing the window or updating the model.

2.1.2.3. Limitations

Because scripts can execute arbitrary Python code, it is important to be aware of their limitations:

- Scripts are executed only when a parameter or the script itself changes. If the script implicitly depends on values in other parts of the model, they will still be shown as up-to-date when these values change.
- New objects created by a script are not tracked. If the script runs again, objects created in a previous execution are not deleted.

2.1.2.4. Tips and Best Practices

Based on the above limitations, adhere to the following guidelines for writing scripts to ensure consistent behavior:

1. **Dependencies:** The values set by the script should only depend on the input parameters.
2. **Idempotency:** If the script is designed to execute multiple times, the model should not change. For example, if the script generates new objects, it must also delete those objects created during the previous execution.

2.1.2.5. Sorting Scripts

When updating the model, out-of-date scripts are executed in the order shown in the Tree View. You can change this order in the following ways:

1. From the context menu of the **Scripts** folder, sort the scripts alphabetically:

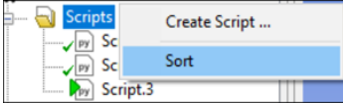

2. Select one or more Scripts in the Tree View, and move them after another Script by doing one of the following:
 - Use the cut-and-paste options from the target Script's context menu (shown below).
 - Use the Cut (**Ctrl+X**) and Paste (**Ctrl+V**) hotkeys.
 - Use the mouse to drag-and-drop the Scripts.
3. From the context menu of an individual Script (as shown below), choose **Reorder Scripts ...** to place it before or after another Script.

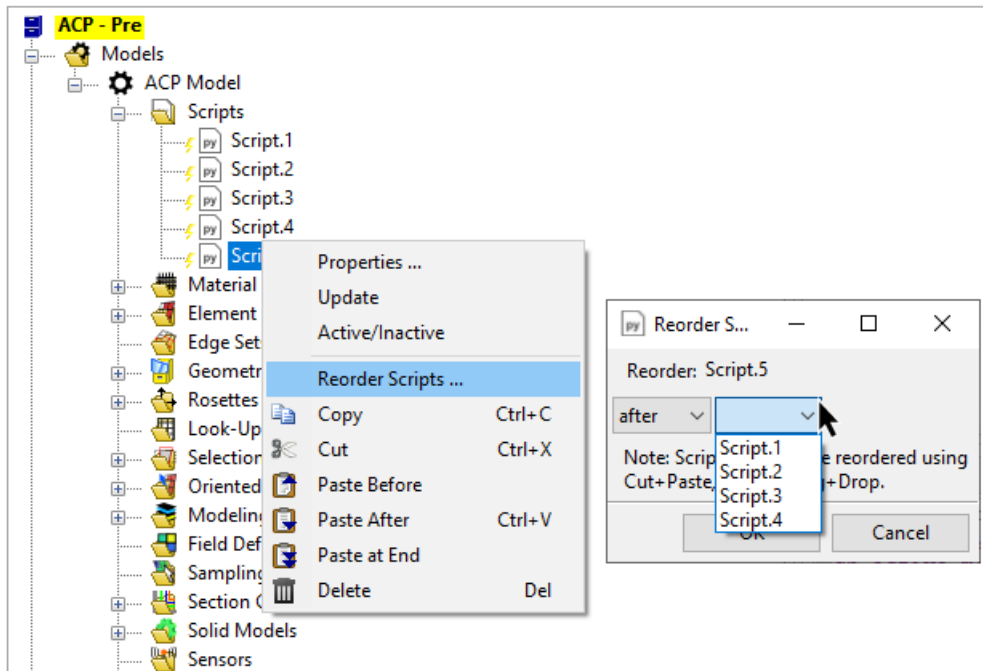

2.1.3. Material Data

ACP differentiates between four material classes: [Materials](#) (p. 75), [Fabrics](#) (p. 84), [Stackups](#) (p. 88) and [Sublaminates](#) (p. 93).

- The [Materials](#) (p. 75) class is the material database in ACP.
- The [Fabric](#) (p. 84) class is where **Materials** can be associated with a ply of a set thicknesses.

- The [Stackup \(p. 88\)](#) class is used to combine fabrics into a non-crimp fabric, such as a [0 45 90] combination.
- The [Sublaminates \(p. 93\)](#) class is used to group fabrics and stackups together for frequently used lay-ups.

A **Stackup** or a **Sublaminates** can only be defined if a fabric and material have been defined previously.

2.1.3.1. Materials

The **Materials** database is only editable within ACP in Stand Alone mode. Otherwise, it draws all material properties from Engineering Data within Workbench. In this case, the material properties can be viewed- but not altered- in ACP.

2.1.3.1.1. Materials Context Menu

The context menu of the **Materials** class has the following options:

- **Create Material** (Stand Alone only): Open a **Material Properties** dialog for creating a new material.
- **Paste** (Stand Alone only): Paste a copied material into the material database.
- **Sort**: Sort the list of materials alphabetically.
- **Export**: Export the material database into a .csv file, ESAComp XML file, or an Ansys Workbench XML file.
- **Import** (Stand Alone only): Import materials from a .csv file or ESAComp XML file.

More information on the import and export of ESAComp XML file can be found in [ESAComp \(p. 258\)](#). **Stackups** and **Sublaminates** can also be exported to an ESAComp XML file format but are converted to laminates in the process.

Figure 2.14: Materials Class Context Menu in Stand Alone Mode

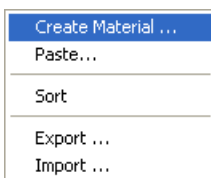

2.1.3.1.2. Temperature Dependent and General Variable Material Properties

Engineering constants, density, fabric fiber angle, as well as stress and strain limits, can be set to depend on scalar field variables, including Temperature, Shear Angle, and Degradation Factor. Other properties can only depend on temperature. The material properties are always shown at the reference point in the Materials object. Variable material data can be edited in Workbench Engineering Data.

In ACP, variable material data are considered in ACP-Post when evaluating failure criteria. Temperature-dependence comes into effect if the solution contains a temperature data block. Shearing of plies is considered if the material is dependent on the **Shear Angle** variable and at

least one ply is draped. All other dependencies require the respective field variable to be defined by means of Look-Up Tables. For more information, see [Variable Material Data in Composite Analyses](#) (p. 303) and [Analysis Using Variable Material Data](#) (p. 320).

Within the Workbench workflow, variable data are passed to and from ACP. In Stand-Alone mode, temperature-dependent data are passed to and from ACP if the import and export is in an Ansys file format, such as .CDB.

General variable material properties are read only from the Workbench Engineering Data (.ENGD) file. Export and import of material data within the Materials object via .CSV or .XML file formats do not support general variable material data.

2.1.3.1.3. Material Properties Dialog

Here is the **Material Properties** dialog.

The screenshot shows the 'Material Properties' dialog box. The 'Name' field contains 'Epoxy Carbon UD (230 GPa) Prepreg' and the 'ID' field contains the same text. Under the 'General' section, the 'rho constant' is set to '1.49e-09' and the 'Ply Type' is set to 'Regular (uni-directional)'. The 'Engineering Constants' section has a note 'This property set is constant' and a grid of input fields for E1 (1.21e+05), E2 (8600), E3 (8600), v12 (0.27), v13 (0.27), v23 (0.4), G12 (4700), G31 (4700), and G23 (3100). Below the grid are two columns of checkboxes: the first column includes 'Thermal Expansion Coefficients' (checked), 'Fabric Fiber Angle' (unchecked), 'Strain Limits' (checked), and 'Stress Limits' (checked); the second column includes 'Puck Constants' (checked), 'Puck for Woven' (unchecked), 'Tsai-Wu Constants' (checked), and 'LaRC Constants' (unchecked). At the bottom are 'OK', 'Apply', and 'Cancel' buttons.

In the **Material Properties** dialog, the following preprocessing data is required:

- **Name:** Name of the material.
- **ρ:** Density of the material.
- **Ply Type:** Defines the material type and controls which failure criteria evaluates the safety of a certain material (see [Failure Criteria vs. Ply Type Table in the Composites Theory Reference](#)). Depending on the extrusion method (e.g. sandwich-wise extrusion) in the Solid Model, it also affects the volume mesh of the solid model .
 - **Adhesive:** Materials of this type are post-processed with specific failure criteria. An adhesive has isotropic mechanical properties.
 - **Honeycomb Core:** Sandwich core material with a honeycomb pattern.
 - **Isotropic:** Isotropic material and post-processed with the von Mises criterion.

- **Isotropic Homogeneous Core:** Sandwich core material, such as foam, with isotropic elasticity. Note that orthotropic strength limits have to be defined for post-processing (failure criteria evaluation).
- **Orthotropic Homogeneous Core:** Sandwich core material, such as balsa, with an orthotropic material characteristic.
- **Regular (uni-directional):** Uni-directional reinforced material.
- **Undefined:** If the material type is not known or not defined, then the ply type becomes undefined. This material type is **not** post-processed.
- **Woven:** Weave material.

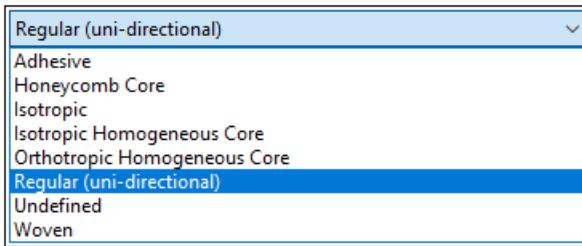

- **Orthotropic Young's Modulus:**
 - **E1:** In-plane, in fiber direction (fiber direction is corresponding to angle 0 for the ply's definition)
 - **E2:** In-plane, orthogonal to fiber direction
 - **E3:** Out of plane direction
- **Orthotropic Poisson's Ratio:**
 - ν_{12} : In-plane
 - ν_{13} : Out of plane, in fiber direction
 - ν_{23} : Out of plane, normal to fiber direction
- **Orthotropic Shear Modulus:**
 - **G12:** In-plane
 - **G13:** Out of plane, in fiber direction
 - **G23:** Out of plane, normal to fiber direction

Further failure properties can be activated. Depending on the **Ply Type** some properties are deactivated automatically.

Note:

Engineering Data can only be modified in preprocessing. Once postprocessing has been initiated the data is frozen.

2.1.3.1.4. Thermal Expansion Coefficients

For thermal stress analyses, the thermal expansion coefficients of the material and the reference temperature must be given:

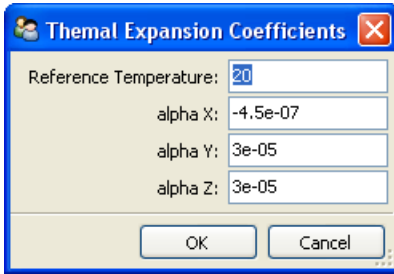

- **Reference Temperature:** Temperature at which strain in the design does not result from thermal expansion or contraction
- **alpha X:** In-plane, in fiber direction (fiber direction is corresponding to angle 0 for the ply's definition)
- **alpha Y:** In-plane, orthogonal to fiber direction
- **alpha Z:** Out of plane direction

2.1.3.1.5. Fabric Fiber Angle

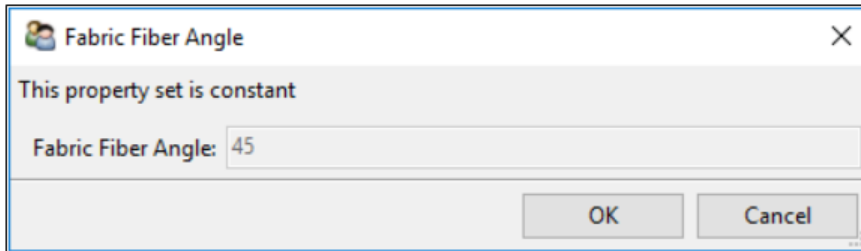

The **Fabric Fiber Angle** represents the angle between the Material 1 Direction and the Draped Fiber Direction. When no draping is specified, the Draped Fiber Direction coincides with the Fiber Direction. By default, the Fabric Fiber Angle is set to zero so that the Material 1 Direction coincides with the (draped) fiber direction.

Figure 2.15: Example of Woven Material with a 45° Fabric Fiber Angle

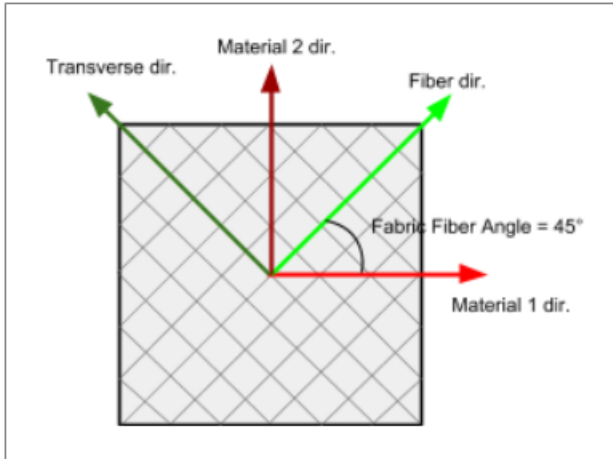

When the Fabric Fiber Angle property is active and nonzero, you need to specify the Material Properties, Thermal Expansion Coefficients, Strain Limits and Stress Limits with respect to the material directions rather than the fiber directions. For instance, E1 and E2 would represent the Young's moduli in the material 1 and 2 directions, respectively. However, the fiber direction is still the nominal modeling direction in ACP. For more information, see the [Shear Dependent Materials in Composite Analysis \(p. 335\)](#) example and the [Material Designer User's Guide](#).

You can highlight the effect of the Fabric Fiber Angle by plotting the draped fiber direction and the material 1 direction of a selected analysis ply (see [Draping \(p. 29\)](#)).

2.1.3.1.6. Strain Limits

The **Strain Limits** are used to calculate the IRF if the **Max Strain** criteria is selected in the failure criteria definition. Compressive strain limits must be negative.

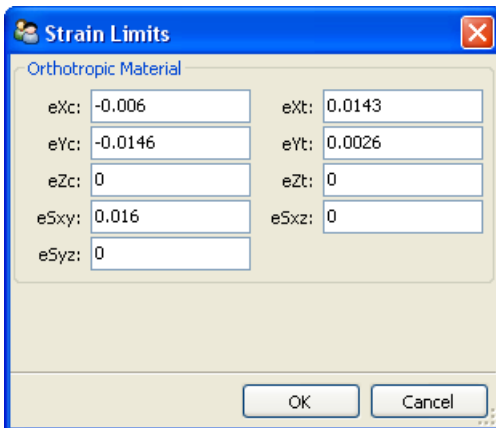

For orthotropic materials, 9 strain limits (5 in-plane and 4 out-of-plane strains) can be entered:

- **eXc**: Normal strain, in-plane, in fiber direction, compression limit
- **eXt**: Normal strain, in-plane, in fiber direction, tension limit
- **eYc**: Normal strain, in-plane, orthogonal to fiber direction, compression limit
- **eYt**: Normal strain, in-plane, orthogonal to fiber direction, tension limit

- **eZc**: Normal strain, out of plane, compression limit
- **eZt**: Normal strain, out of plane, tension limit
- **eSxy**: In-plane shear strain
- **eSxz**: Transverse (interlaminar) shear strain, plane in fiber direction
- **eSyz**: Transverse (interlaminar) shear strain, plane normal to fiber direction

If the material is defined as isotropic, the **von Mises Strain Limit** can be entered:

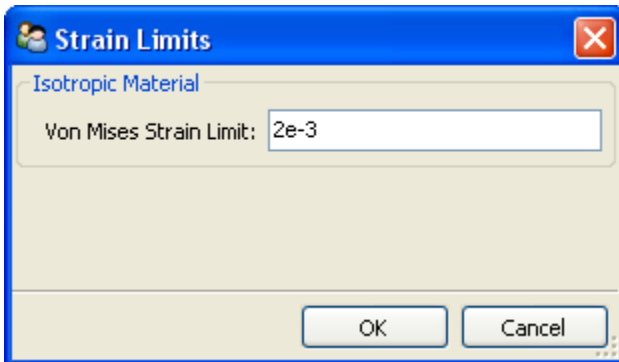

2.1.3.1.7. Stress Limits

All the other **Failure Criteria** definitions are based on values defined in the **Stress Limits** dialog. Compressive stress limits must be negative.

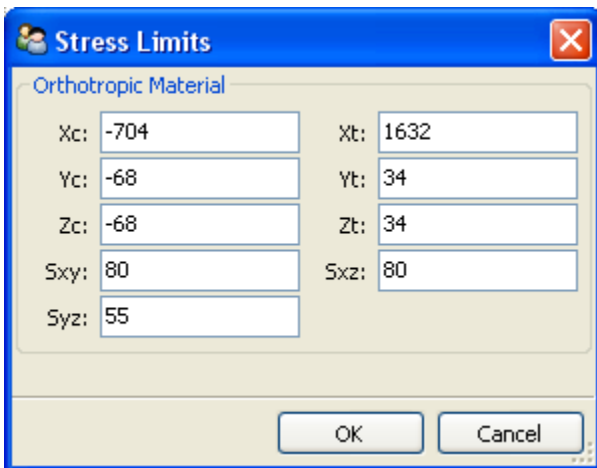

For orthotropic materials, 9 stress limits (5 in-plane and 4 out-of-plane strains) can be entered:

- **Xc**: Normal stress, in-plane, in fiber direction, compression limit
- **Xt**: Normal stress, in-plane, in fiber direction, tension limit
- **Yc**: Normal stress, in-plane, orthogonal to fiber direction, compression limit
- **Yt**: Normal stress, in-plane, orthogonal to fiber direction, tension limit
- **Zc**: Normal stress, out of plane, compression limit

- **Zt**: Normal stress, out of plane, tension limit
- **Sxy**: In-plane stress strain
- **Sxz**: Transverse (interlaminar) shear stress, plane in fiber direction
- **Syz**: Transverse (interlaminar) shear stress, plane normal to fiber direction

If the material is defined as isotropic the **von Mises Stress Limit** can be entered (equivalent to **Tensile Yield Strength** in Engineering Data):

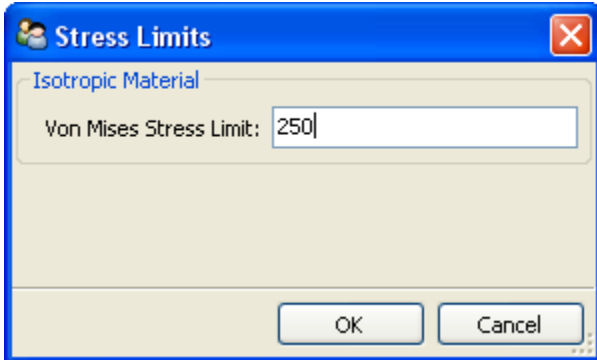

2.1.3.1.8. Puck Constants

The Puck failure criterion requires internal parameters, which depend on the material. The **Material Classification** drop-down menu offers a selection of pre-defined constants and also allows for the definition of custom constants. The menu has the following options:

- **Carbon**: Sets pre-defined Puck constants for carbon fiber materials.
- **Glass**: Sets pre-defined Puck constants for glass fiber materials.
- **Material-specific**: Allows you to set your own Puck constants.
- **Ignore Puck Criterion**: No constants are set.

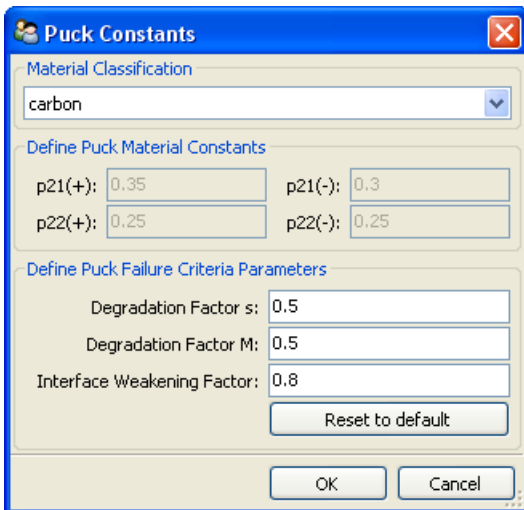

- **p21(+)**: Tensile inclination XZ

- **p21(-)**: Compressive inclination XZ
- **p22(+)**: Tensile inclination YZ
- **p22(-)**: Compressive inclination YZ
- **s** and **M**: Degradation parameters
- **Interface Weakening Factor**: Scales the interlaminar normal strength

2.1.3.1.9. Puck for Woven

ACP's **Puck for Woven** functionality allows you to evaluate the Puck failure criterion for woven materials. You specify two UD plies to represent the woven ply. During the failure evaluation, ACP evaluates the stresses for these plies in the new material directions and computes the Puck failures. The relative ply angles, engineering constants, stress limits, and Puck constants must be defined for both plies.

This approach, proposed by [Puck \(p. 369\)](#), has been validated by experiments. Warp dominated woven fabrics have yielded good results. Puck described that fabrics with similar amounts of reinforcement in the warp and weft direction (50%/50%)– and therefore having higher fiber undulation– need additional material characterization.

An alternative to Puck for Woven is the [Maximum Stress Criterion](#). It does not require additional material properties (or characterization), and it has been successfully applied in different commercial projects.

Note:

This specification does not affect the analysis model and is only considered in the failure analysis for the Puck criterion.

Woven Characterization for Puck Failure Criterion

UD 1 | UD 2

Fiber direction: 0

Transversal-isotropic Material Properties

E1: 0 E2: 0 E3: 0
v12: 0 v13: 0 v23: 0
G12: 0 G13: 0 G23: 0

Stress Limits

Orthotropic Material

Xc: 0 Xt: 0
Yc: 0 Yt: 0
Zc: 0 Zt: 0
Sxy: 0 Sxz: 0
Syz: 0

Puck Constants

Material Classification

ignore Puck criterion

Define Puck Material Constants

p21(+): 0.325 p21(-): 0.275
p22(+): 0.225 p22(-): 0.225

Define Puck Failure Criteria Parameters

Degradation Factor s: 0.5
Degradation Factor M: 0.5
Interface Weakening Factor: 0.8

Reset to default

OK Cancel

2.1.3.1.10. Tsai-Wu Constants

The Tsai-Wu constants are constants used into the interaction coefficient of the quadratic failure criteria for Tsai-Wu formulation. For more details, refer to [Tsai-Wu Failure Criterion in the Composites Theory Reference](#).

Tsai-Wu Constants

XY: 1
XZ: -1
YZ: -1

OK Cancel

In ACP the Tsai-Wu constants correspond to:

- $2 F_{12} = \mathbf{XY}$, default -1

- $2 F_{13} = \mathbf{XZ}$, default -1
- $2 F_{23} = \mathbf{YZ}$, default -1

2.1.3.1.11. LaRC Constants

The LaRC failure criteria requires the following parameters to evaluate the failure in matrix and fiber:

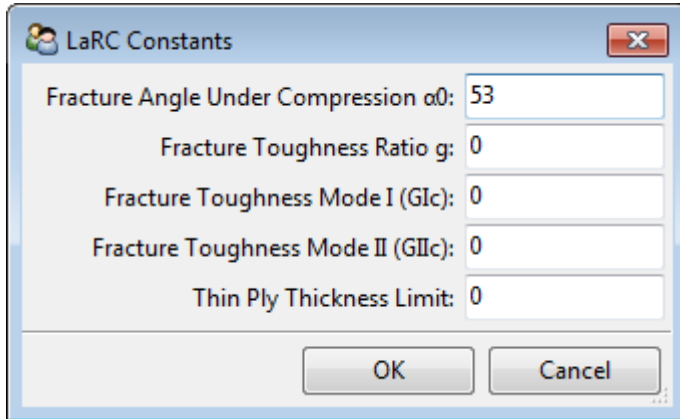

- **Fracture Angle Under Compression:** The value for α_0 used in the LaRC fiber and matrix failure. Default value is 53° .
- **Fracture Toughness Ratio:** The ratio of the mode I to mode II fracture toughness, which is used in the fiber failure criteria.
- **Fracture Toughness Mode I**
- **Fracture Toughness Mode II**
- **Thin Ply Thickness Limit** (set to 0.7 mm in Workbench mode)

For more information, see [LaRC03/LaRC04 Constants in the Composites Theory Reference](#).

2.1.3.2. Fabric

The settings for the **Fabric Properties** dialog are described in the sections below:

2.1.3.2.1. General

Figure 2.16: Fabric Properties - General

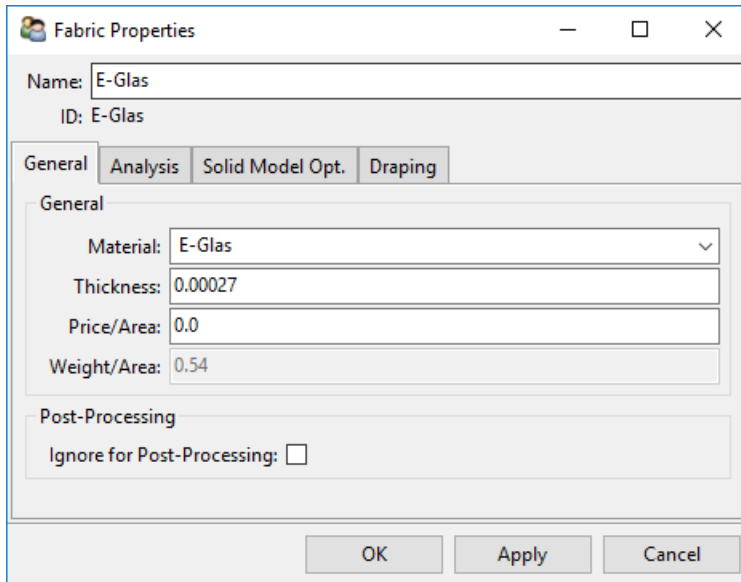

- **Material:** Material of the fabric
- **Thickness:** Ply thickness
- **Price/Area:** The surface price can be given to provide global information. For more information, see [Sensors](#) (p. 181).
- **Weight/Area:** The weight per unit area is calculated based on the thickness and material density.
- **Ignore for Post-Processing:** If active, all the analysis plies with this fabric are not considered in the failure criteria analysis during postprocessing. This does not affect the analysis model.

2.1.3.2.2. Polar Properties

The **Polar Properties** ([Classical Laminate Theory in the Composites Theory Reference](#)) of the fabric can be plotted as graphical information.

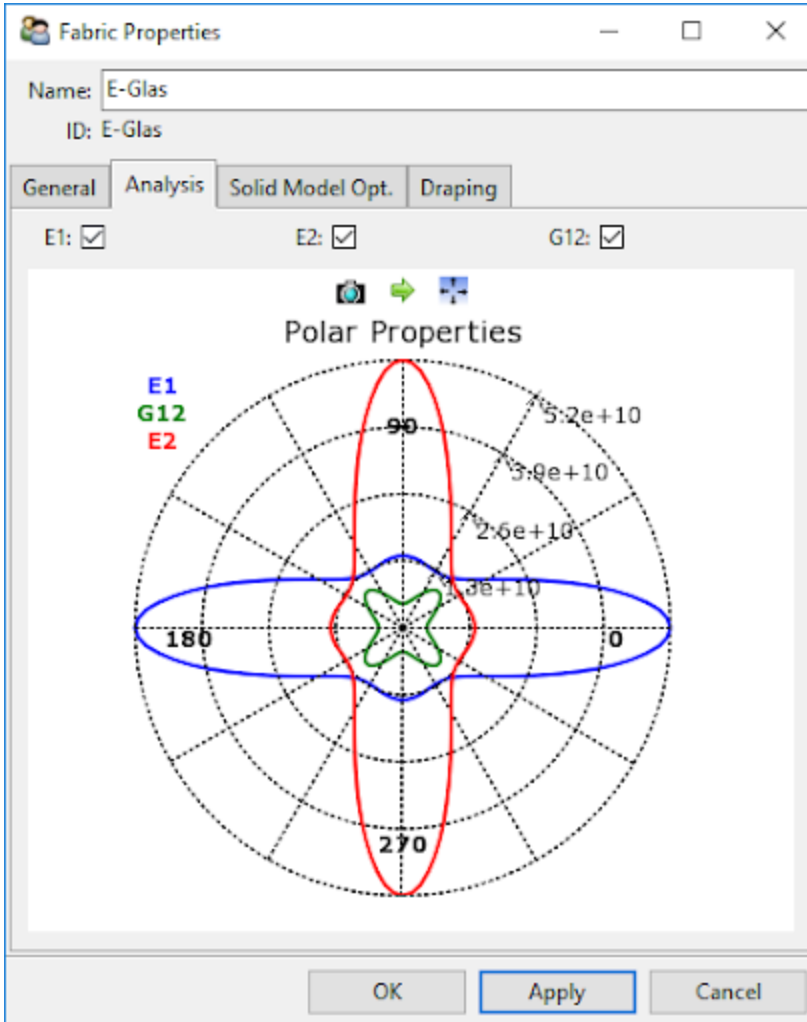
Figure 2.17: Fabric Properties - Analysis

This plot can be exported as a picture (📷) or in a .csv file (📁)

2.1.3.2.3. Fabric Solid Model Options

Solid model options set which material is used for diminished (Drop-Off and Cut-Off) elements during solid model generation. Material handling is determined by the settings in every Fabric/Stackup definition, the global Drop-Off/Cut-Off material handling setting, and the extrusion method in the Solid Model definition. For more information, see [Material Handling for Different Extrusion Methods](#) (p. 207).

Note:

The **Solid Model Options** tab is the same for both Fabrics and Stackups.

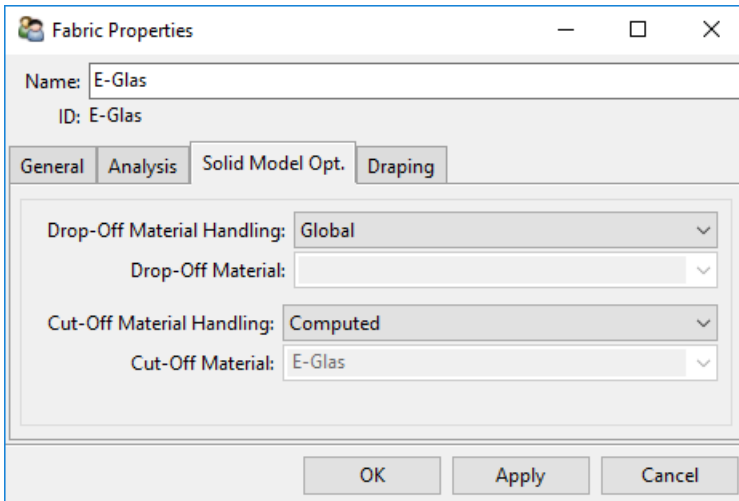
Figure 2.18: Fabric Properties - Solid Model Options

- **Drop-Off Material Handling:**
 - **Global:** The global Drop-Off material in the **Solid Model Properties** is used. (default)
 - **Custom:** Select a material from the **Drop-Off Material** drop-down menu.
- **Drop-Off Material:** The list becomes active when **Drop-Off Material Handling** is set to **Custom**.
- **Cut-Off Material Handling:**
 - **Computed:** The Fabric/Stackup material is used for analysis ply-wise extrusion. Otherwise, the global material is used and a warning is generated that computed materials for Cut-Offs are currently not supported if the element points to more than one Analysis Ply. (default)
 - **Global:** The global Drop-Off material in the **Solid Model Properties** is used.
 - **Custom:** Select a material from the **Cut-Off Material** drop-down menu.
- **Cut-Off Material:** The list becomes active when **Cut-Off Material Handling** is set to **Custom**.

2.1.3.2.4. Draping

The Draping settings are used if draping is activated in the Modeling Ply definition. For more details about the draping calculation, see [Draping Simulation](#).

Note:

The **Draping** tab is the same for both Fabrics and Stackups.

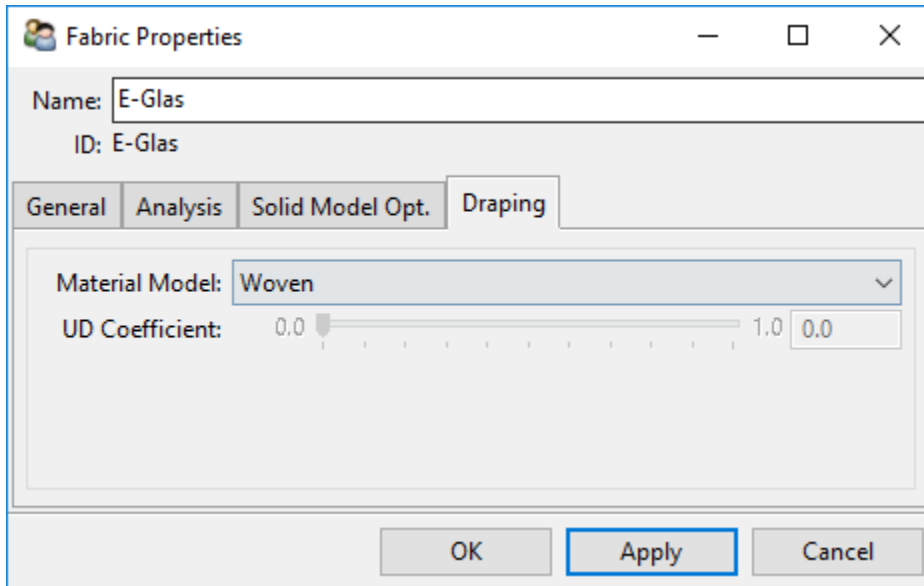
Figure 2.19: Fabric Properties - Draping

- **Material Model:** The material model used in the draping simulation, either **Woven** (default) or **Unidirectional**. Note that the draping material model can be set independently of the Ply Type of the fabric's material.
- **UD Coefficient:** A parameter between 0 and 1 which controls the amount of deformation in the transverse draping direction. This property is active only when **Material Model** is set to **Unidirectional**.

2.1.3.3. Stackup

A stackup is a non-crimp fabric with a defined stacking sequence. From a production point of view, it is considered as one ply, which is applied on the form. For the analysis, all plies forming the stackup are considered. For every ply of the stackup, the fabric and its orientation must be given:

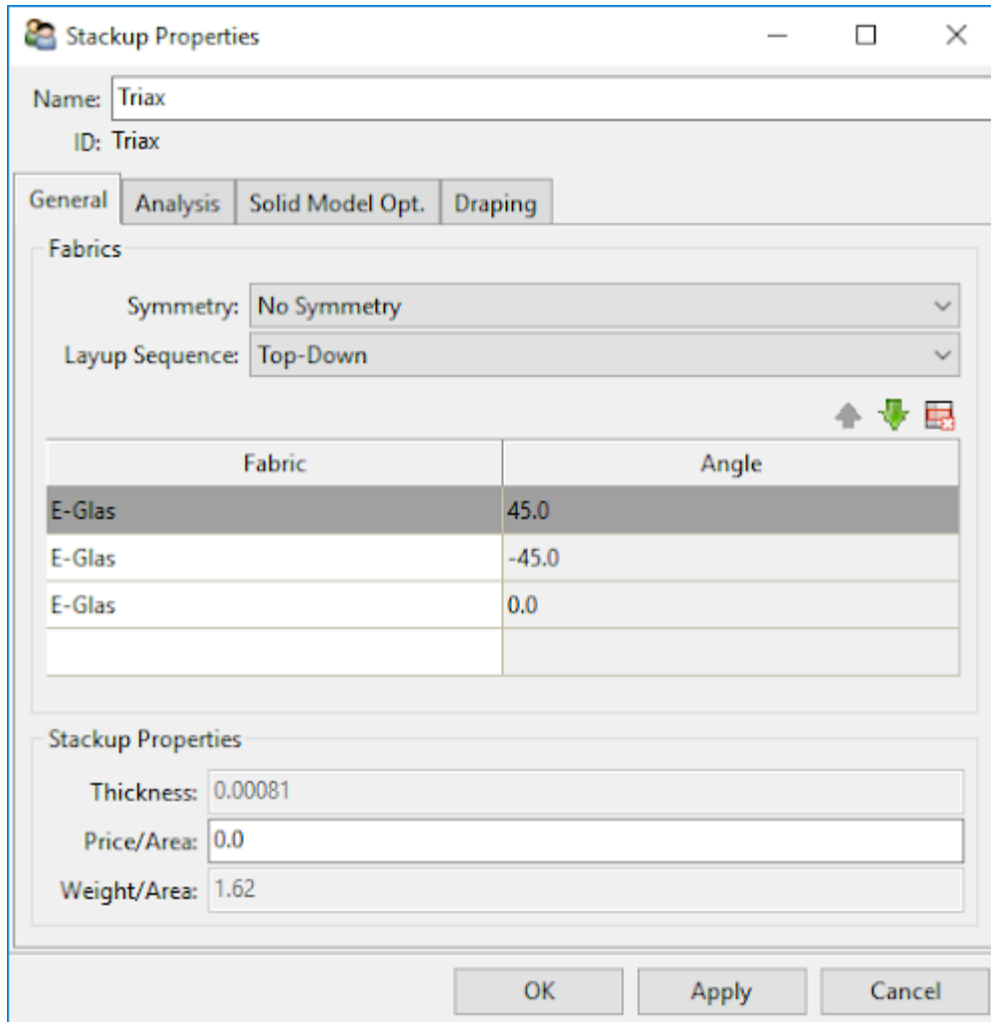
Figure 2.20: Stackup Properties - General

These stackups have different **Price/Area** and solid model options than a laminate of single plies. For this reason, **Price/Area** can be entered again. Stackups can be exported to an ESAComp XML file format and are converted to laminates in the process.

2.1.3.3.1. Top-Down or Bottom-Up Sequence

The definition of the stackup can be given in both directions (**Bottom-Up** and **Top-Down**). In the **Top-Down** sequence, the first defined ply (the first one in the list) is placed first on the mold and is the bottom of the stackup. The other plies are placed over it. During analysis, the sequence can be checked. In the above figure, the ply 45 direction is on top (see [Figure 2.20: Stackup Properties - General](#) (p. 89)).

2.1.3.3.2. Symmetries

For a quicker definition, the stackup can be defined with symmetries.

The **Even Symmetry** option defines the symmetry axis on the top of the sequence, and uses all plies.

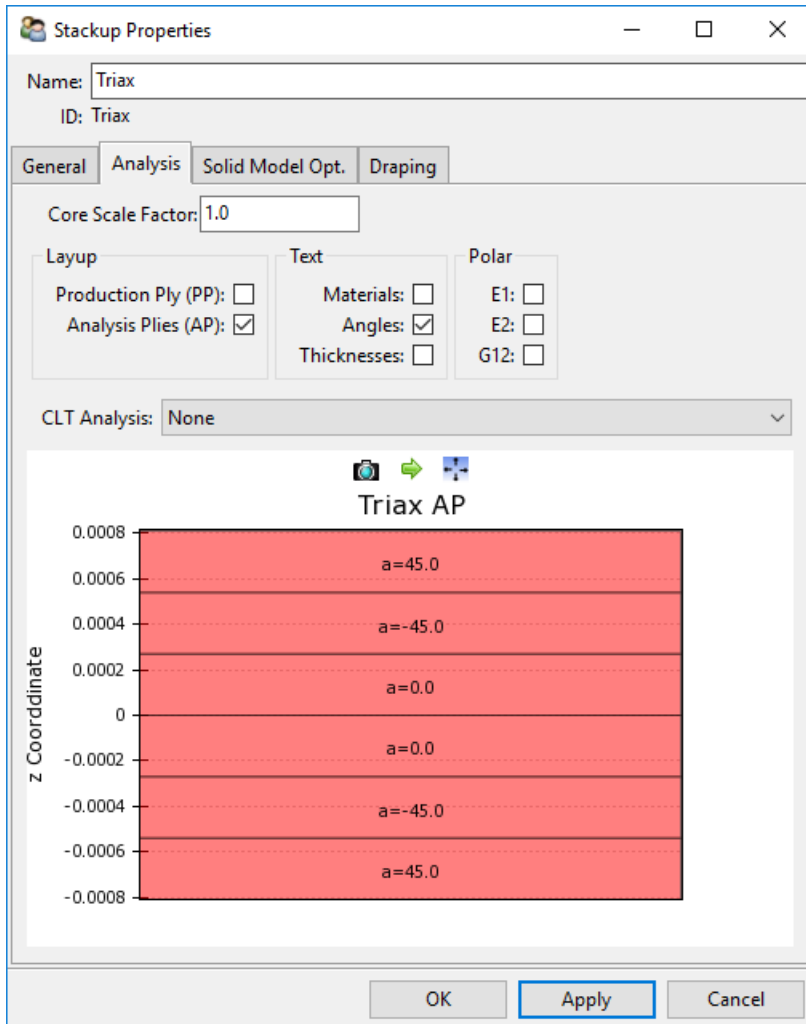
Figure 2.21: Stackup Sequence with Even Symmetry

In the **Odd Symmetry** option, the ply on the top is not used for the symmetry. So the middle of the top ply is the symmetry axis of the final sequence.

Figure 2.22: Stackup Sequence with Odd Symmetry

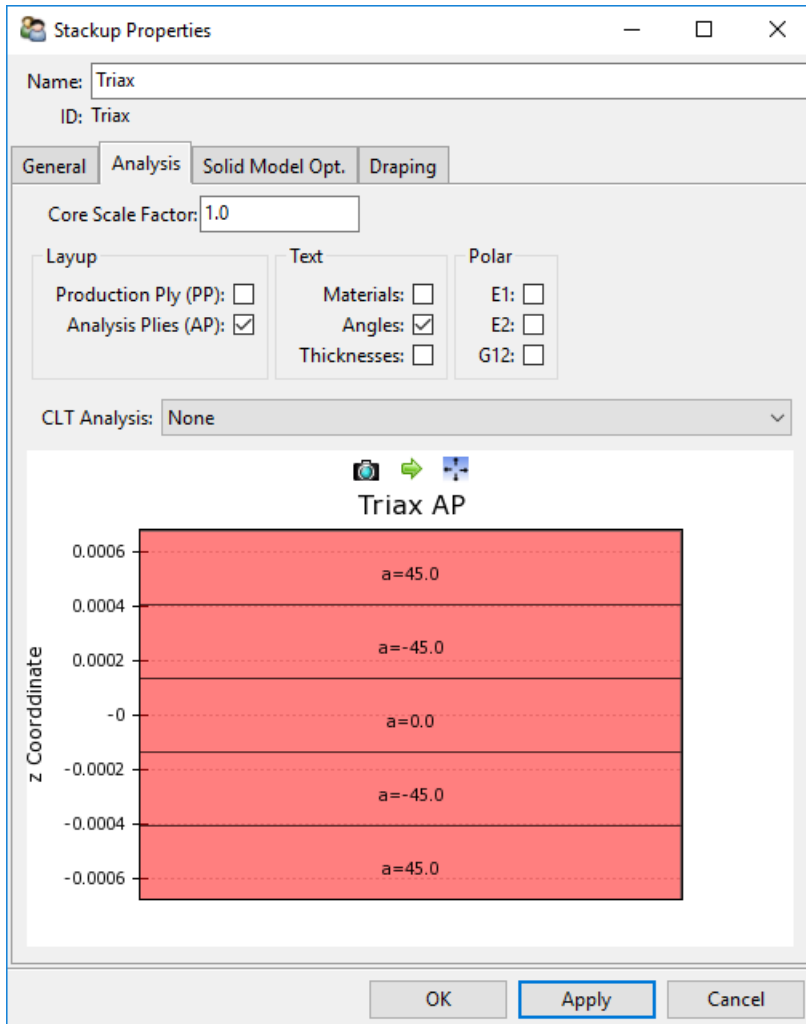

2.1.3.3.3. Analysis

The **Analysis** tab provides evaluation of the laminate properties of the stackup, which can be plotted as graphical information.

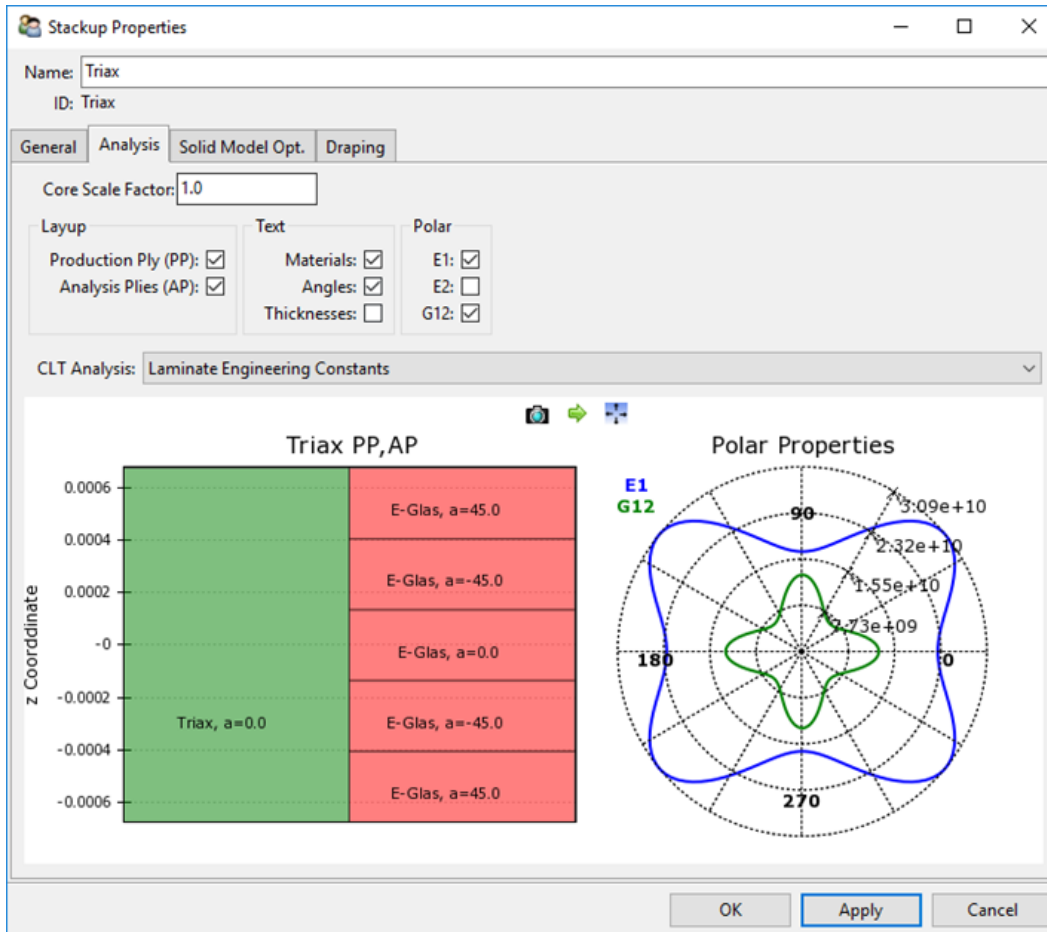
Figure 2.23: Lay-Up Information and Polar Properties

This plot can be exported as a picture (📷) or as a .csv file (📁). It is possible to translate and zoom into the lay-up distribution with the mouse button. To come back to a fit view, click 📏. In addition, laminate properties (stiffness matrix or flexural stiffness), which are based on [Classical Laminate Theory](#) (CLT), can be calculated.

The following results based on [Classical Laminate Theory](#) can be calculated by selecting them from the **CLT Analysis** drop-down:

- **Laminate Stiffness and Compliance Matrices**
- **Normalized Laminate Stiffness and Compliance Matrices**
- **Laminate Engineering Constants**

Figure 2.24: CLT Analysis - Laminate Engineering Constants

Property	Value
Flexural Laminate Shear Stiffness	1.31152e+10
Flexural Laminate Stiffness E1	1.49836e+10
Flexural Laminate Stiffness E2	1.47689e+10
Laminate Shear Stiffness	1.28228e+10
Laminate Stiffness E1	2.26953e+10
Laminate Stiffness E2	1.67163e+10
Out of Plane Shear G23	2.29488e+09
Out of Plane Shear G31	2.2895e+09
Shear Correction Factor k44 (G23)	0.655681
Shear Correction Factor k55 (G31)	0.654142

2.1.3.3.4. Stackup Solid Model Options

The material handling settings for Solid Models are identical for Fabrics and Stacks. For more information, see [Fabric Solid Model Options \(p. 86\)](#).

2.1.3.3.5. Draping Options

The Draping settings are identical for Fabrics and Stacks. For more information, see [Draping \(p. 87\)](#).

2.1.3.4. Sublaminates

A sublaminate is a sequence of plies defined by fabrics and stackups with relative angles. This sublaminate can be used later in the lay-up definition. As with stackups, you can choose the sequence direction and symmetry. Refer to [Symmetries \(p. 89\)](#) for more information. Sublaminates can be exported to an ESAComp XML file format and converted to laminates in the process.

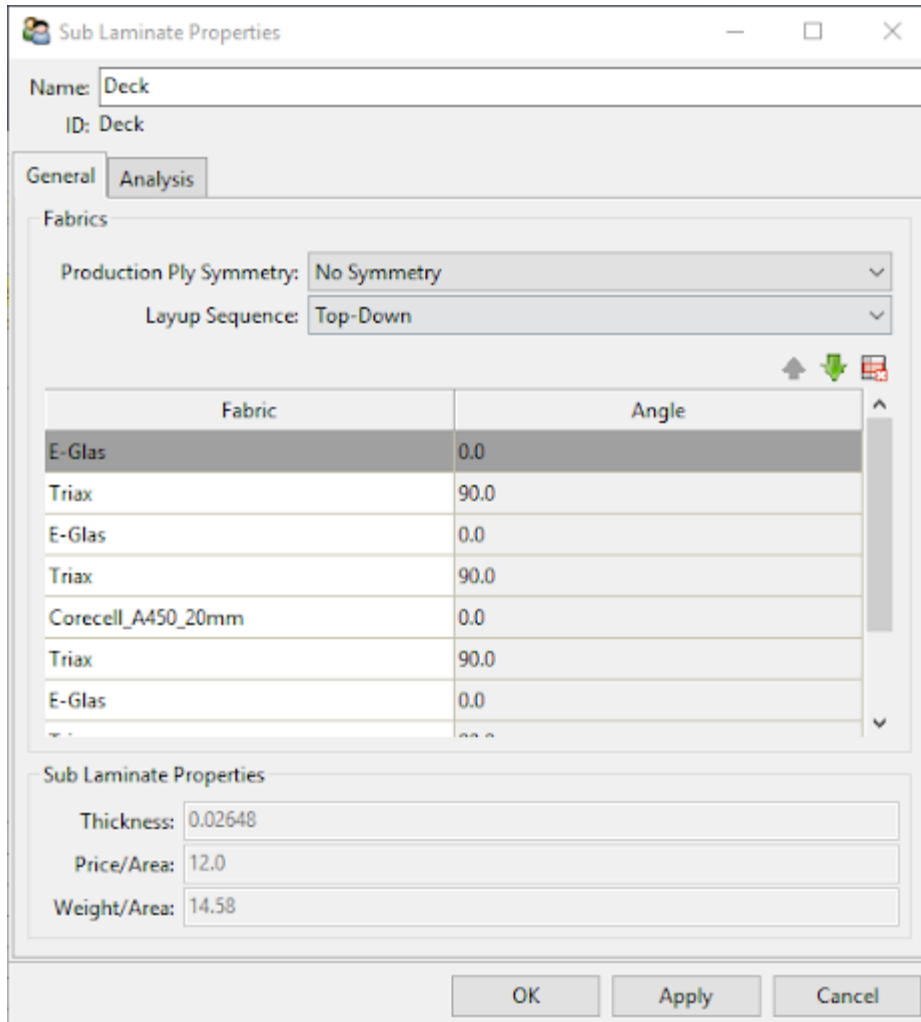
Figure 2.25: Sub Laminate Properties - General Tab

The **Analysis** tab is exactly the same as for a stackup. Refer to [Analysis \(p. 91\)](#) for information on the content of this tab.

Important:

If the sublaminde definition uses stackups and symmetry, the stackup is not reversed in the ply sequence. For example, for a stackup S1 defined as [45,-45,0], and a sub-laminde defined with even symmetry and the stackup ([S1]s), the sub-laminde sequence is [45,-45,0,45,-45,0], not [45,-45,0,0,-45,45].

2.1.4. Element and Edge Sets

Named selections defined in Mechanical or components defined Mechanical APDL can be imported into ACP. These selections are imported with the same names. Faces (element components in Mech-

anical APDL) are imported as [Element Sets \(p. 95\)](#) and edges (node components in Mechanical APDL) as [Edge Sets \(p. 96\)](#).

Important:

After the definition of a new Named Selection in Mechanical, the model must be updated.

2.1.4.1. Element Sets

New Element Sets can be manually defined by selecting individual elements. Element Sets store the element labels and are therefore not associated with the geometry. If the mesh changes, the element numbering changes and the element set must be redefined to avoid erroneous lay-ups.

Figure 2.26: Element Set Selection

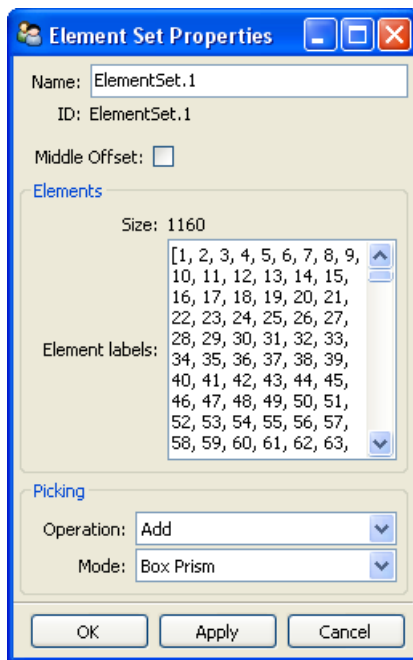

- **Middle Offset:** If the mesh is generated at the mid-plane surface, activate this option such that the section definition is translated to where the middle of the section corresponds to the element. The lay-up definition - in particular the definition of Oriented Selection Sets - is not influenced. Solid Model extrusion and Draping Offset Correction do not support the **Middle Offset** setting. To verify a lay-up with **Middle Offset**, use a [Section Cut \(p. 170\)](#) or [Sampling Point \(p. 168\)](#).
- **Operation:** **Add** or **Remove** elements in the list.
- **Mode:** Define the selection mode by dragging the mouse from one corner to the other.
 - **Box on Surface:** Only visible elements are selected.
 - **Box Prism:** All elements included in the box are selected, depth included.
 - **Point:** Element at the picking location is selected.

2.1.4.1.1. Context Menu

Several options are available in the Element Set context menu:

- **Properties:** Open the Element Set property window.
- **Update:** Update any changes into the database
- **Hide/Show:** Hide or show this Element Set. The elements of the hidden Element Sets are no longer visible in the Scene.
- **Copy:** Copy the selected Element Set to the clipboard.
- **Paste:** Paste an Element Set from the clipboard.
- **Delete:** Delete the selected Element Set
- **Export Boundaries:** Export the boundaries of the Element Set to a STEP or an IGES file
- **Partition:** Create partitioned Element Sets for any Element Set that can be divided in different zones, due to a geometrical separation (for example, three elements share the same edge).

Figure 2.27: Element Set Context Menu



2.1.4.2. Edge Sets

Named Selections of connected edges in Mechanical are transferred to ACP as Edge Sets. New Edge Sets can also be defined manually in ACP-Pre:

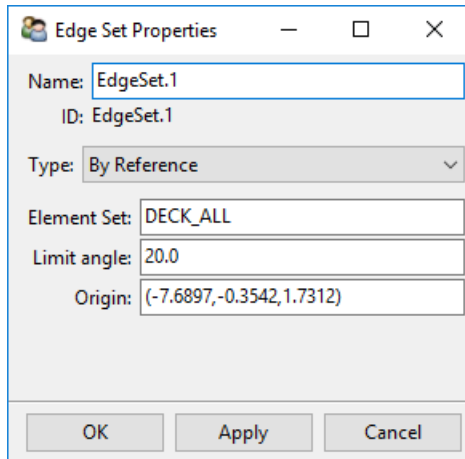
Figure 2.28: Edge Set Definition

- **Edge Set Type:** How the Edge Set is defined:
 - **By Reference:** Defined the Edge Set using an existing Element Set (activates the following options):
 - **Element Set:** The Element Set of which the Edge Set is part.
 - **Limit Angle:** The Edge Set is extended from the origin in both directions until the angle between two elements is bigger than the **Limit Angle**. If the **Limit Angle** is set to a negative value, the Edge Set is the whole boundary of the selected Element Set.
 - **Origin:** Origin to determine the closest boundary.
 - **By Reference:** An existing Element Set is used to define a new Edge Set through one boundary limited by an angle diffusion.
 - **By Nodes:** Manually select the nodes to define the Edge Set.

2.1.5. Geometry

Geometries can be used to build complex lay-ups during preprocessing in ACP. For example, core of variable thickness can be modeled as a ply whose thickness is set by an imported geometry of the core. Cut-Off Rules can be based on geometry, therefore controlling the lay-up by a CAD surface or at a pre-defined offset to a CAD surface. Geometries are particularly helpful in generating solid models where geometry-based Extrusion Guides, Snap-To and Cut-Off operations can create intricate shapes.

For more information on the use of geometries in a lay-up definition, see the following sections:

- [Ply thickness definition \(p. 146\)](#) in Modeling Groups
- [Geometry-based Cut-Off Selection Rule \(p. 121\)](#)
- [Extrusion Guides \(p. 195\)](#), [Snap-To \(p. 200\)](#) and [Cut-Off Geometries \(p. 202\)](#) in Solid Models (p. 185)

CAD geometries are incorporated in an ACP model by creating a link to a **Geometry** in the Workbench Project Schematic or by directly importing an external geometry (IGES or STP format). These CAD

geometries may be surfaces, bodies, or assemblies of parts. The concept of virtual geometries allows you to select and group specific regions or bodies of the imported CAD geometry and use them for subsequent modeling operations. All geometry-based operations are based on virtual geometries. Virtual geometries act as a reference to one or more faces or bodies of one CAD geometry.

Note:

Typically, operations based on CAD geometries are computationally intensive, so it is important to define your geometries efficiently. For example, it is much more efficient to have multiple small geometrical operations rather than a single large one. Small geometries process faster because ACP, prior to running the calculation, filters out all extraneous points and elements. The figure below illustrates three smaller Cut-Off geometries defined instead of one large one. The principle also applies to all other operations based on geometry.

Figure 2.29: Example of three Cut-Off geometries

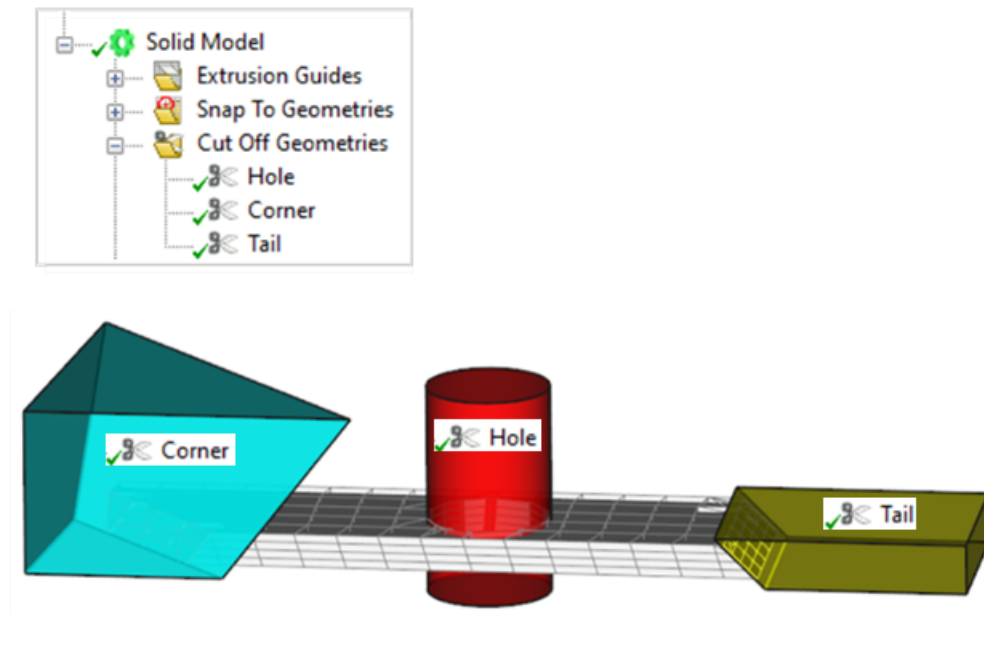
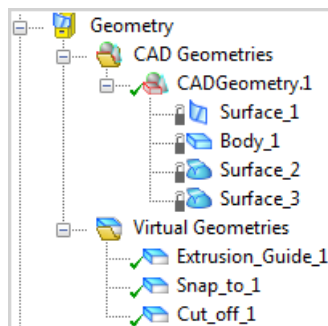

Figure 2.30: CAD Geometry Assembly and Virtual Geometries in the Tree View



2.1.5.1. CAD Geometries

There are two ways to import an external geometry into ACP:

- The first option is directly through ACP, directly importing copies of the CAD file into the `user_files` directory in the Workbench file structure. Any further changes to the original file are not transferred.
- By selecting the **Setup** cell of your ACP system and then selecting the **Load Model Properties** option (**Geometry** category of the **Properties of Schematic**) in Workbench. The advantage of this option is that the CAD geometry can be refreshed inside DesignModeler or Discovery Modeling.

For either case, the geometry remains intact when a project is archived and restored.

The parts included in an imported CAD geometry are displayed once the CAD geometry is up-to-date. If the imported CAD geometry is an assembly of parts, multiple parts are shown in the Tree underneath the CAD geometry. ACP makes the distinction between four different types of parts:

- **Face** (🔵): Single face
- **Surface** (🔵): Single surface body
- **Solid** (🔵): Single volume body
- **Compound** (🔵): Combination of multiple connected surfaces and/or bodies

Performance:

- **Features based on a CAD geometry** can demand a lot of computational resources if you apply them to areas with many elements and/or nodes. You can improve computational performance by splitting the CAD Geometry into smaller parts so you are working with multiple [Virtual Geometries \(p. 101\)](#) as shown below. The reason is that costly computations are only performed for the elements and/or nodes which are inside the bounding box of the selected geometry. Of course, this improves performance only if the intersection between the bounding box of the geometry and shell mesh is small.

In the example below, it is more efficient to work with two [Virtual Geometries \(p. 101\)](#) because the bounding box of each individual shape is much smaller than the shell mesh and so the costly computations are performed only for a few shell elements instead of the entire mesh.

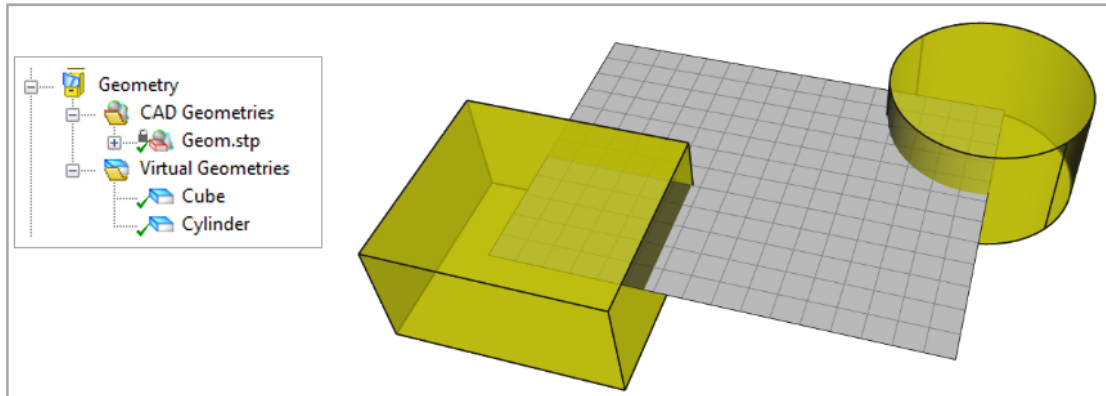
Figure 2.31: Example of Multiple Virtual Geometries

→ **Loading a CAD Geometry** can become slow if the CAD file contains many separate shapes due to a system limitation. The workaround is to import multiple smaller CAD files.

2.1.5.1.1. Direct Import

Geometry import has the following options:

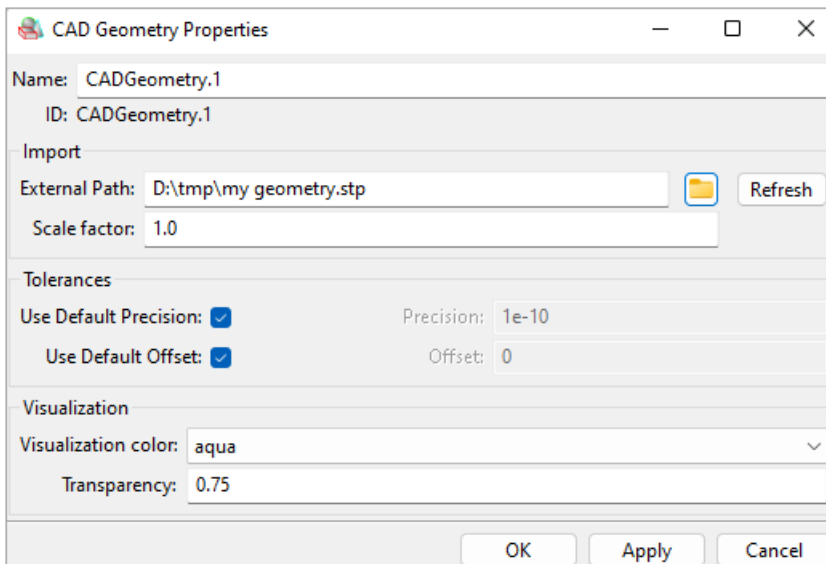
Figure 2.32: Property Dialog CAD Geometry

- **Name:** Name of geometry for use in the database.
- **External Path:** Location of the geometry file to be imported.
- **Refresh:** Reload the file from the external path. The file is automatically copied to the Workbench project folders.
- **Scale Factor:** Scale the geometry in the global coordinate system (useful for change of units).
- **Precision:** Precision of the imported geometry. This value is used to evaluate intersections and other geometrical operations.

- **Offset:** Sets the default capture tolerance value associated with the CAD geometry for operations such as the [Geometrical Selection Rule](#) (p. 125).
- **Use Default Offset:** Boolean which sets the offset to 10% of the average element size.
- **Visualization Color:** Color in which the imported geometry is displayed.
- **Transparency:** Transparency of the imported geometry (value between 0 and 1).

Assemblies should be imported as a single .STP file rather than individual ones containing links.

2.1.5.1.2. Workbench Geometry Link

The geometry component in Workbench can be used to link CAD geometries with ACP-Pre. The linked geometry is scaled automatically if its units do not match those of the project. The required steps for geometry import are:

1. Add a **Geometry** component to the project.
2. In the context menu of the **Geometry** select Import Geometry
3. Link the **Geometry** cell to the ACP (Pre) **Setup** cell

The imported geometry appears under **CAD Geometries** in ACP.

Figure 2.33: Project Schematic with a CAD Geometry Import in ACP

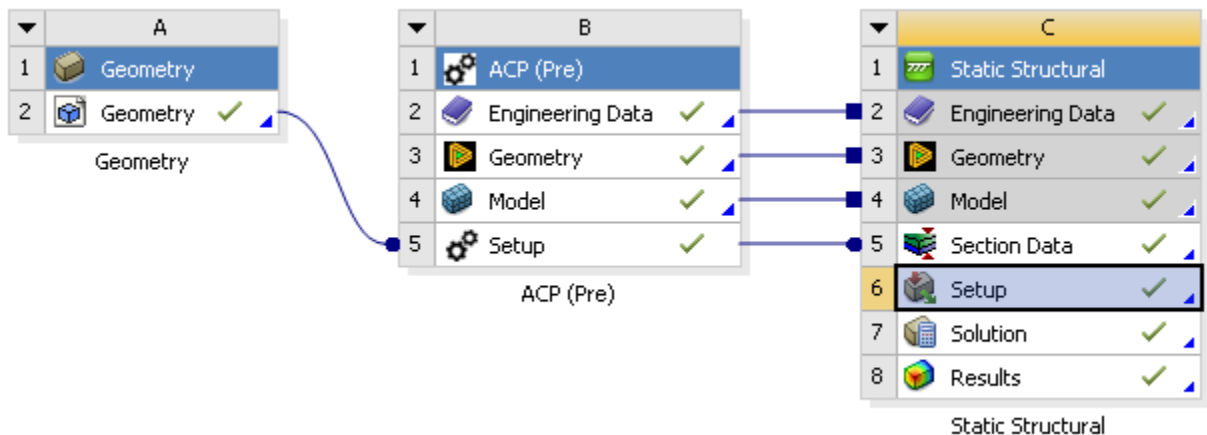

2.1.5.2. Virtual Geometries

Virtual Geometries group together sub-shapes of CAD Geometry parts. The sub-shapes are referenced by linking to the features of CAD Geometry parts. See [CAD Geometries](#) (p. 99) for information on how working with geometries impacts system performance.

There are three ways to define virtual geometries:

- Directly from CAD parts through the CAD part context menu.

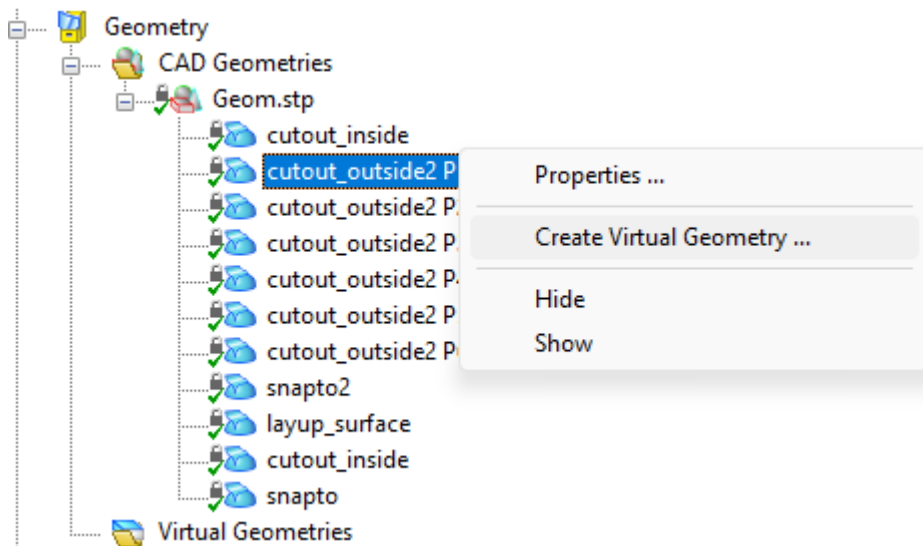
Figure 2.34: Create Virtual Geometry Directly from CAD Geometry Part

- By selecting multiple CAD parts from the Tree when the **Virtual Geometry Properties** dialog is open.

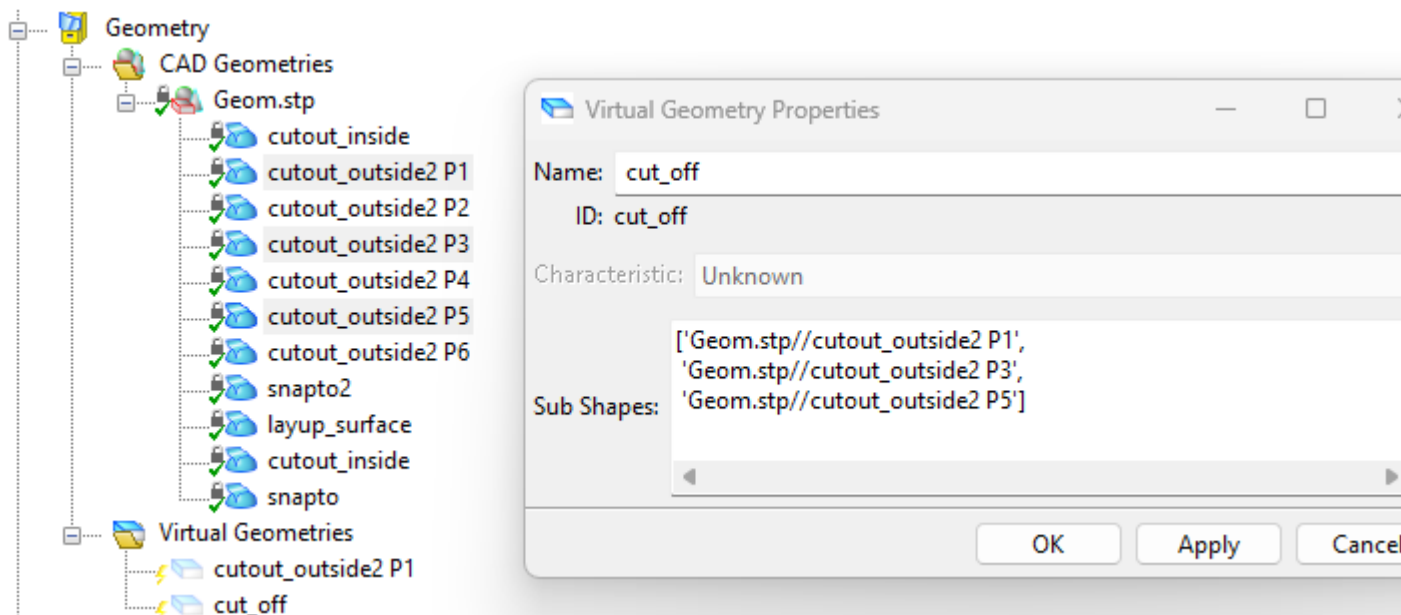
Figure 2.35: Create Virtual Geometry Through CAD Geometry Parts in Tree

- Through face selection in the Scene.

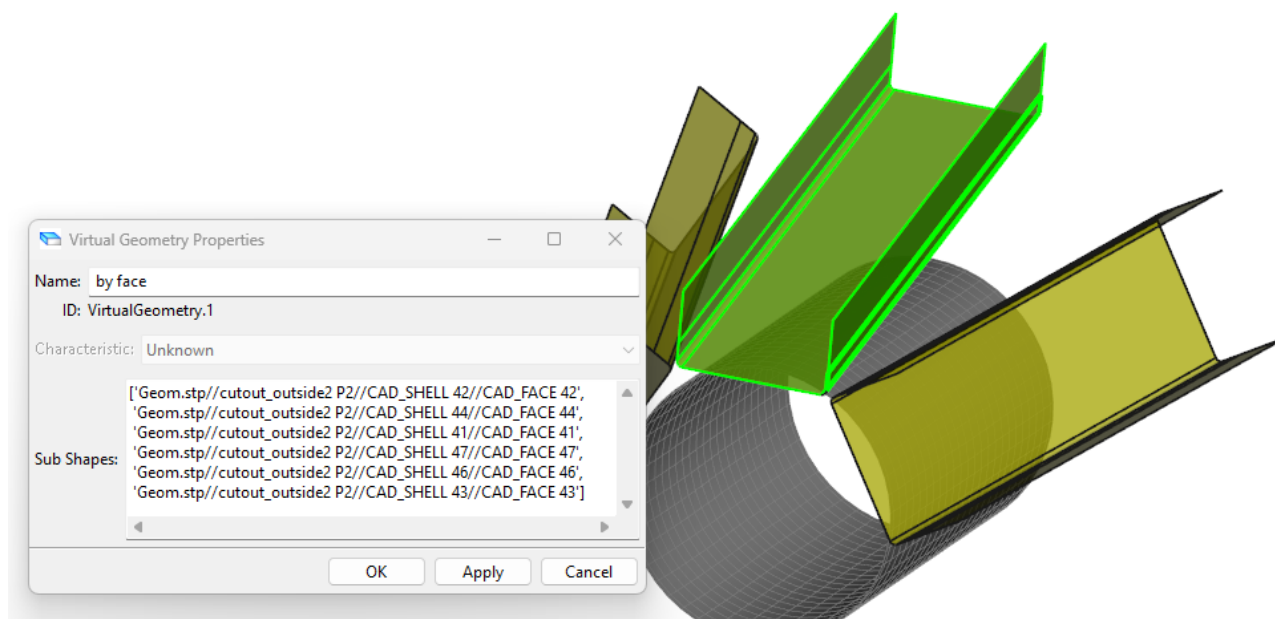
Figure 2.36: Create Virtual Geometry Through Face Selection in the Scene**Note:**

Virtual geometries can only reference parts from one CAD geometry.

2.1.6. Rosettes

Rosettes are coordinate systems used to set the Reference Direction of Oriented Selection Sets. Rosettes define the 0° direction for the composite lay-up. Coordinate systems defined in Mechanical are imported by default and the naming is maintained between Mechanical and ACP. Additional Rosettes can be defined in ACP. There are 5 different types of Rosettes. The origin and directions of Rosettes are given in the global coordinate system. Rosettes are independent of the mesh, even if you select nodes and elements to define their properties.

One or more Rosettes can be used to set the Reference Direction for elements in an Oriented Selected Set (OSS). The **Selection Method** in the OSS definition controls which Rosette determines the Reference Direction for the elements. The Reference Direction for a single element is determined by a projection of the applicable Rosette onto the element. Different Rosette types can be used to define the Reference Direction.

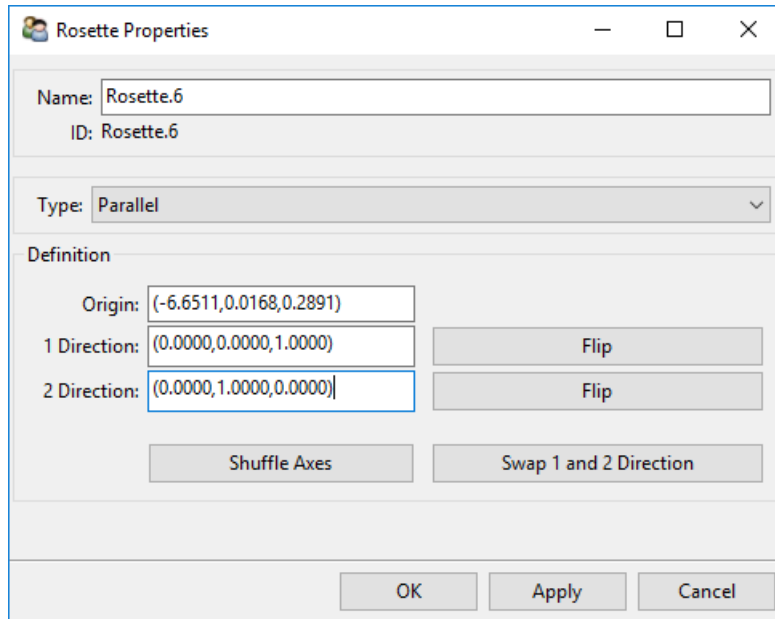
Figure 2.37: Rosette Properties Dialog

- **Flip Buttons:** Reverse the direction
- **Shuffle Axes:** Rotate coordinate system to exchange the X, Y, and Z axis.
- **Swap 1 and 2 Direction:** Exchange direction 1 with 2.

Rosette Types

- **Parallel:** Analogous to a Cartesian coordinate system. The Reference Direction is given by the Rosette's X direction.
- **Radial:** the Reference Direction for a radial Rosette is perpendicular to the Z direction. The Z direction lies orthogonal to **Direction 1** and **Direction 2** in the Rosette properties. The Reference Direction for an individual element is defined by the vector of Rosette origin to element center which is projected onto the element. If the direction vector cannot be projected the alternate **Direction 1** is chosen.

Figure 2.38: Oriented Selection Set with a Radial Rosette.

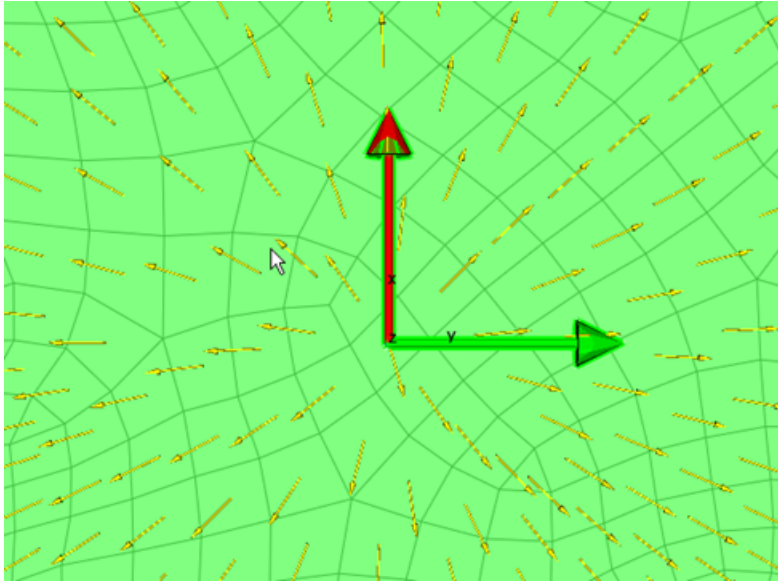

- **Cylindrical:** Based on a cylindrical coordinate system. The Reference Direction runs circumferentially around the Rosette's Z direction according to the right hand rule. The Z direction is defined by the X and Y direction vectors. Flip the Z direction to reverse the Reference Direction.

Figure 2.39: Oriented Selection Set with a Cylindrical Rosette

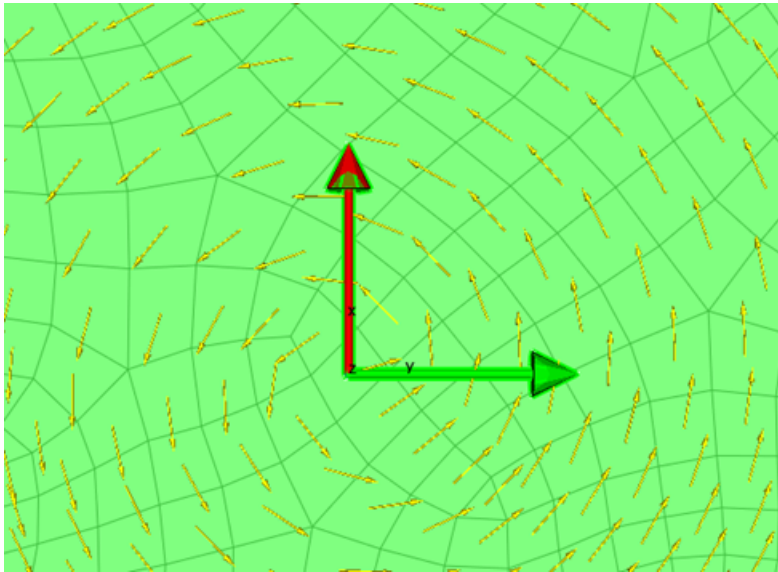

- **Spherical:** Based on a spherical coordinate system. The Reference Direction runs circumferentially around the Z axis of the Rosette.

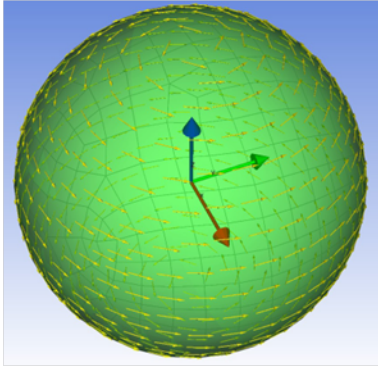
Figure 2.40: Oriented Selection Set with a Spherical Rosette

- **Edge Wise:** Requires the selection of an Edge Set in addition to the usual Rosette definition. The Reference Direction is given by a projection of the Rosette's X direction and the path of the Edge Set. The X direction of the Rosette coordinate system is projected on to the point on the Edge that is closest to the origin of the Rosette. This determines Reference Direction along the Edge Set. The Reference Direction is reversed by switching the coordinates of the Rosette's X direction. An element within an Oriented Selection Set gets its Reference Direction from the direction of the point on the edge that is closest to the element centroid.

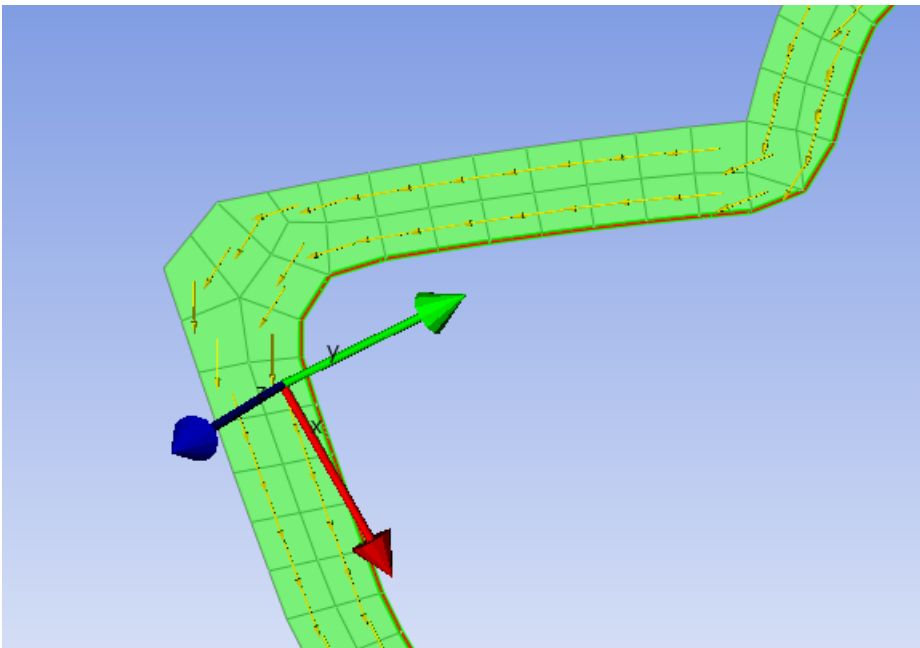
Figure 2.41: Edge-Wise Rosette

2.1.6.1. Rosette Definition

Each Rosette is defined by an origin and two vectors. Enter the origin by clicking on an element or a node, or by typing the coordinates. When selecting an element, the coordinates of the center of the element are used.

If a direction field is selected in the dialog, the selection of an element returns the normal direction of the element. By pushing down the Ctrl key and clicking on a second element, you can select the direction defined by the two element centers.

2.1.7. Look-Up Tables

Several features in ACP can be defined as tabular values. Look-up tables can be used for [thickness definition of plies \(p. 146\)](#), [selection rules \(p. 128\)](#), [draping angles \(p. 142\)](#), and [field definitions \(p. 165\)](#). In such cases, the Look-up Table contains values (scalars) or direction (vectors) at specified points in 3D space or along a single direction.

Look-Up Tables require at least a **Location** column (1 or 3 components, one for each coordinate). **Direction** columns (3 columns) and/or **Scalar** columns can be added. The Look-Up Table can be edited efficiently by exporting and importing an `.xls(x)` file (see [Edit Entities with Excel \(p. 24\)](#)) or a `.csv` file.(see [CSV Format \(p. 258\)](#)).

Note:

Look-up Table rows cannot be directly added or removed in the ACP GUI. The values in existing cells can only be modified.

Populating Look-Up Tables

The easiest way to populate Look-up Tables is with the help of the [Edit Entities with Excel \(p. 24\)](#) on Windows. The set-up with exporting and importing a `.csv` file is similar and ideal for Linux. Data can also be entered into Look-up Tables using [The ACP Python Scripting User Interface \(p. 56\)](#).

There are three approaches to populating a Look-Up table. This can be done with:

- [The Excel Link \(p. 107\)](#)
- [Exporting/Importing `.csv` Files \(p. 109\)](#)
- [A Python Script \(p. 111\)](#)

2.1.7.1. 3D Look-Up Table With The Excel Link

The set-up of a 3D Look-up Table is demonstrated in the figures below:

From the right-click context menu, select [Create a 3D Look-Up Table \(p. ?\)](#) .

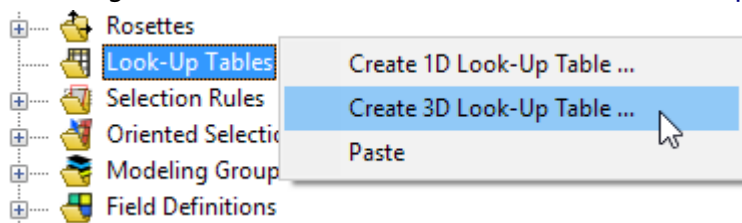

An [empty 3D Look-Up Table \(p. ?\)](#) is created with XYZ-location columns.

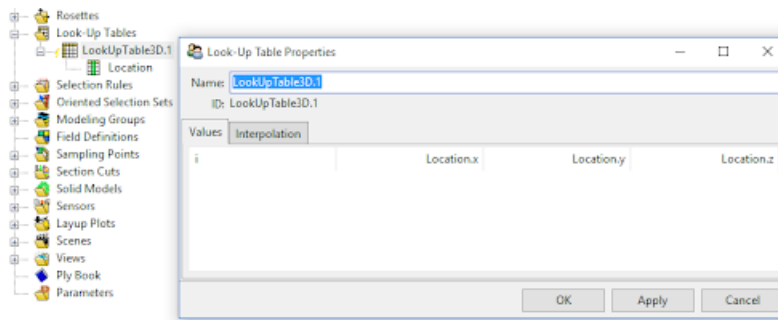

Create Direction Columns (p. ?) from the right-click context menu of the new Look-Up Table.

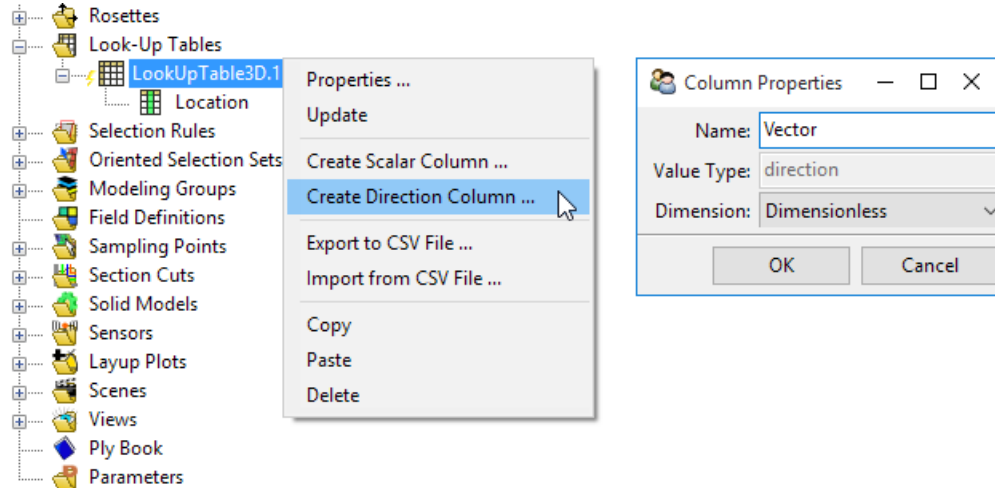

The empty Look-up Table (p. ?) now has three additional columns for three directional components of the vector.

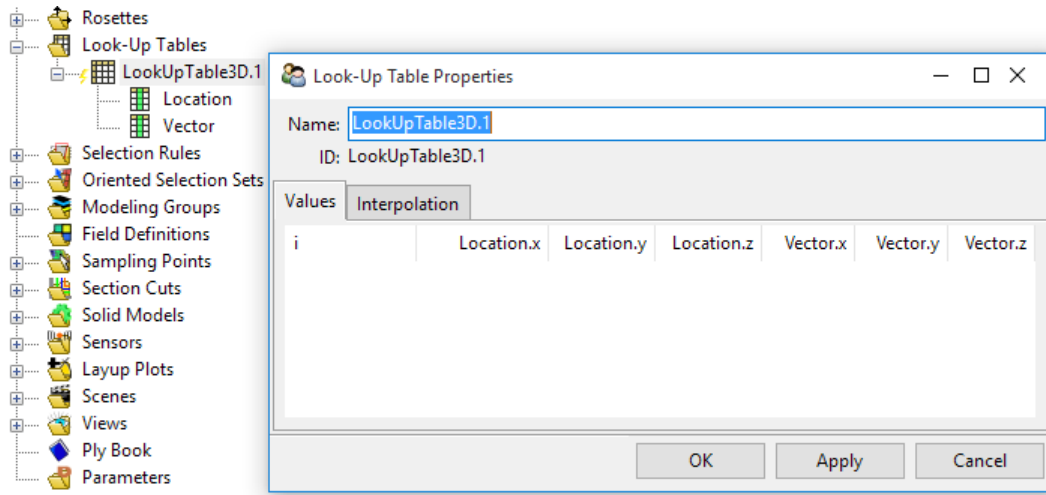

Populate the table in Excel with your values. Ensure the data set is followed by the END DATA and END TABLE rows. An example of a populated Look-Up Table (p. ?) in Excel is shown below.

BEGIN TABLE							
BEGIN DEFINITION							
type	LookUpTable3D						
id	LookUpTable3D.1						
name	LookUpTable3D.1						
use_default_search	TRUE						
search_radius	0						
num_min_neighbors	1						
END DEFINITION							
BEGIN DATA							
column_names	Location.x	Location.y	Location.z	Column.1.x	Column.1.y	Column.1.z	Index [i] (Read Only)
column_types	location	location	location	direction	direction	direction	-----
dimensions	length	length	length	dimensionless	dimensionless	dimensionless	-----
values	0	0	0	1	-1	0	0
	1	0	0	1	1	0	1
	1	1	0	-1	1	0	2
	0	1	0	-1	-1	0	3
END DATA							
END TABLE							

Use the [Excel Link \(p. ?\)](#) to import and export the data from Excel to ACP.

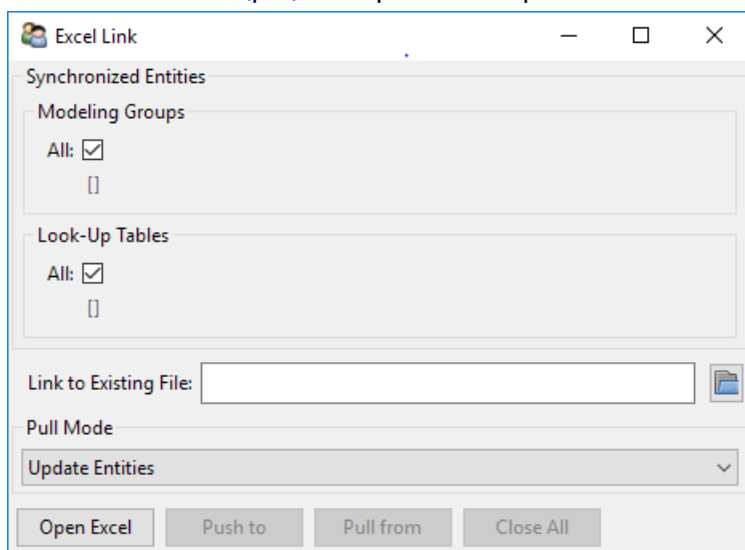

2.1.7.2. 1D Look-Up Table with .csv Files

The Look-up Table definition with a `.csv` file follows the same process as [the Excel Link \(p. 107\)](#): create Look-Up table, add desired columns, export data to Excel, populate the Excel data and re-import. The `.csv` file approach for setting up a 1D look-up table is demonstrated with the figures below.

From the right-click context Look-Up Table menu in the Outline, select [Create 1D Look-Up Table \(p. ?\)](#).

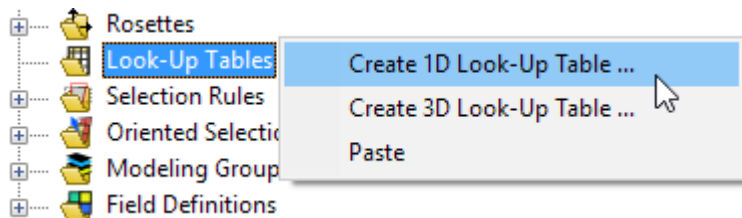

An empty 1D Look-Up table is created with a single column. Specify the origin and direction of the table as shown below.

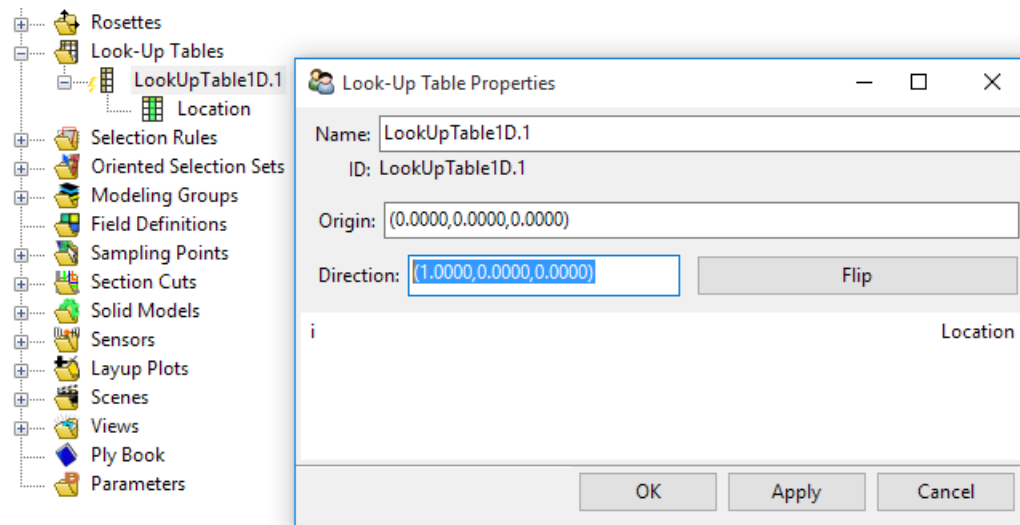

From the right-click context menu of the new Look-Up Table, select **Create Scalar Column** (p. ?)

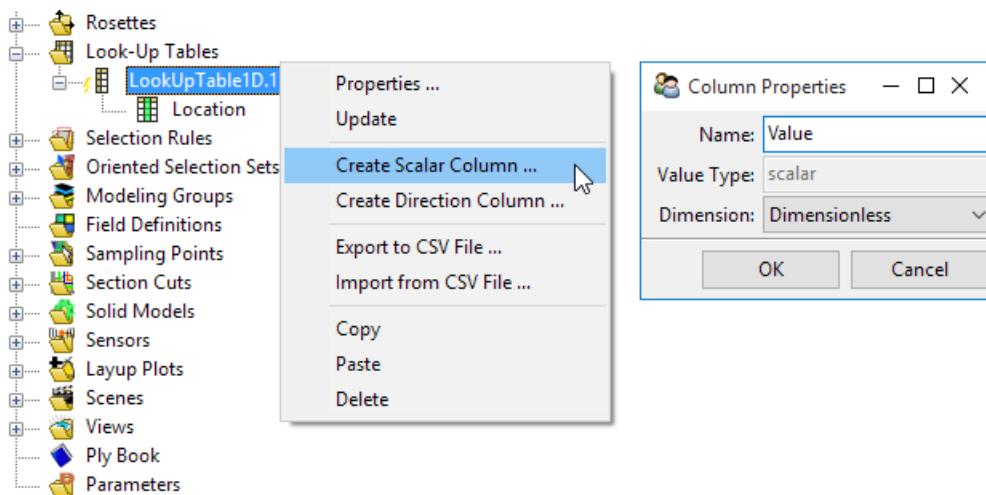

Export the empty Look-Up Table to a .csvfile using the right-click context menu.

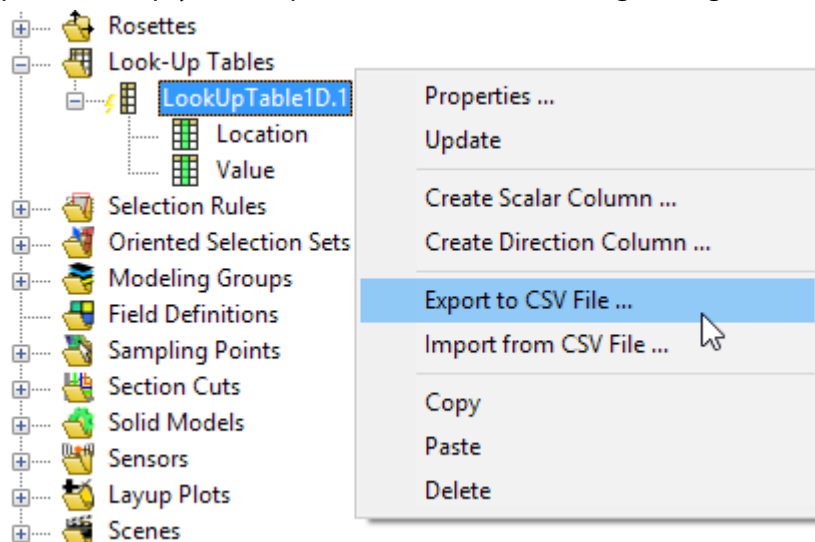

Open the exported .csv file (p. ?) in an editor or spreadsheet program.

```
#
# LookUpTable CSV Interface File
#
# Copyright (c) 2005 - 2018 by ANSYS Switzerland GmbH
# Unauthorized use, distribution, or duplication is prohibited.
#
# Product: ANSYS Composite PrepPost
# Version: 2019 R2
# Written: 2018-12-21 15:19:49
#
origin,direction,column_names,name,num_rows,num_cols,column_types,type,id,dimensions
"(0.0. 0.0. 0.0)". "(0.0. 0.0. 0.0)". ("Location'. 'Value')".LookUpTable1D.1,0,1, ("location',
'scalar')",LookUpTable1D,LookUpTable1D.1, ("length', 'dimensionless')
Location,Value
```

Add the entries and save the CSV file. Note that you may need to verify the delimiter type if your regional settings use a comma as a decimal separator.

Location,Value	column_names	Location	Value
0,0	column_types	location	scalar
1,1	dimensions	length	dimensionless
2,2	values		0 0
3,3			1 1
4,4			2 2
5,5			3 3
			4 4
			5 5

In ACP, re-import the CSV File by selecting **Import from CSV File** (p. ?).

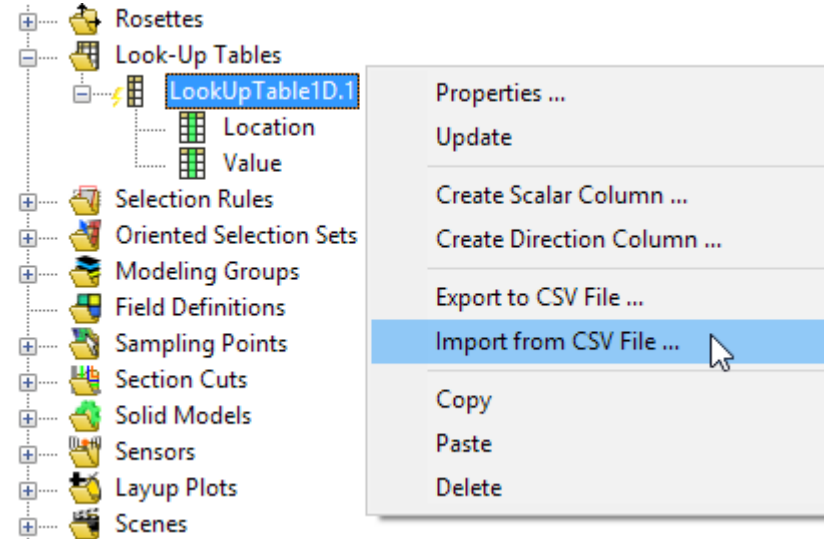

2.1.7.3. Look-Up Table with a Python Script

The set-up of a 1D Look-Up Table with a script:

```
table = db.active_model.create_lookup_table1d(name='LookUpTable1D.1')
table.origin=(0.0, 0.0, 0.0)
table.direction=(1.0, 0.0, 0.0)
table.create_column(name='Value', type='scalar')
table.dimensions=['length', 'dimensionless']
table.columns['Location'].values = [0., 1., 2., 3.]
table.columns['Value'].values = [0., 1., 2., 3.]
```

2.1.7.4. 1-D Look-Up Table

A 1-D Look-Up Table can be used to create a distribution of a scalars or vectors in one direction. Such a distribution can be used in:

- the definition of an [Oriented Selection Set \(p. 132\)](#) Reference Direction.
- the definition of the [draping angle \(p. 279\)](#).
- the definition of the [ply thickness \(p. 146\)](#).

A 1-D Look-Up Table is defined by an origin, a direction vector, and a column of at least one quantity varying along the direction vector. Location points can be defined in an arbitrary order. They are automatically sorted and duplicate location points are permitted for the definition of step functions. The values of the defined quantity are linearly interpolated to the element centers in the mesh. The 1-D Look-Up Table uses a scalar product to project the vector between origin and element center on to the Look-Up Table direction vector and look-up the desired value at that point.

Figure 2.42: Schematic of 1-D Look-Up Table Function

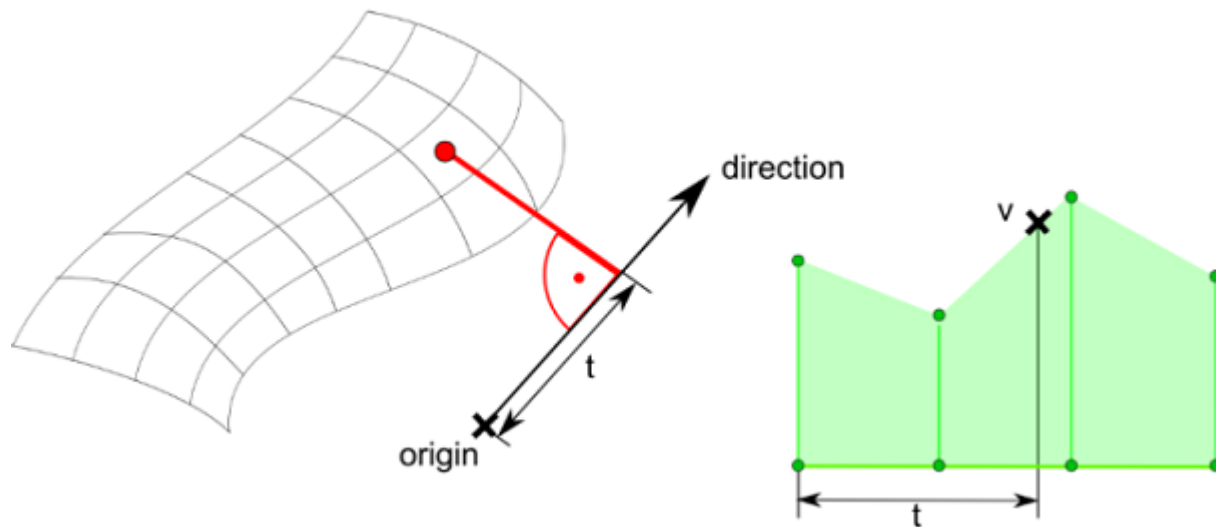

2.1.7.5. 3D Look-Up Table

A 3D Look-Up Table can be used to define field data, such as the variation of fiber directions or variable layer thicknesses. This table can be used for:

- The definition of an [Oriented Selection Set \(p. 132\)](#) Reference Direction.
- The definition of the [draping angle \(p. 279\)](#) (Modeling Ply).
- The definition of the [ply thickness \(p. 146\)](#) (Modeling Ply).

Figure 2.43: Look-Up Table Values

Look-Up Table Properties				
Name: LookUpTable3D				
ID: LookUpTable3D.1				
Values				
Interpolation Algorithm				
i	Location.x	Location.y	Location.z	Degradation
0	-90.000000	60.000000	0.000000	0.500000
1	-80.000000	60.000000	0.000000	0.527778
2	-70.000000	60.000000	0.000000	0.555556
3	-60.000000	60.000000	0.000000	0.583333
4	-50.000000	60.000000	0.000000	0.611111
5	-40.000000	60.000000	0.000000	0.638889
6	-30.000000	60.000000	0.000000	0.666667
7	-20.000000	60.000000	0.000000	0.694444
8	-10.000000	60.000000	0.000000	0.722222

The values in the Look-Up Table are interpolated to the element centers. The **Interpolation Algorithm** tab allows you to choose between different interpolation algorithms and adjust their properties. By default, the interpolation uses the Shepard's method (a 3D inverse distance weighted interpolation) with a reasonable search radius, and the number of interpolation points is 1.

The interpolation algorithm and properties can have a significant effect on the computed values. The selection of the algorithm depends on the distribution of the supporting points and the FE mesh. The example below shows the interpolation with different algorithms for the same field. The spheres are the supporting points, and the color represents the values of the supporting points. The color of the elements represents the interpolated values. Visualize the interpolation on the mesh using the [Look-Up Table Plot](#) (p. 229), which also generated these figures. For more information on interpolation, see [General Interpolation Library](#).

Figure 2.44: Interpolated Values with Weighted Nearest Neighbor, Nearest Neighbor, and Linear Multivariate (From Left to Right)

Figure 2.45: Look-Up Table Interpolation Parameters

The Look-Up Table properties are:

- **Algorithm Type:** Selection of the interpolation algorithm. The supported options are Weighted Nearest Neighbor, Nearest Neighbor, and Linear Multivariate. For more details, see [General Interpolation Library](#).
- Options for **Weighted Nearest Neighbor:**
 - **Use Default Search Radius:** Compute the initial search radius based on the "characteristic distance" of the supported points. Validate this search radius and adjust it if needed.
 - **Search Radius:** Only the element centers within this radius are used in the interpolation.
 - **Min. Number of Interpolation Points:** If there are no element centers (or not enough if > 1) in the radius, the **Search Radius** increases until the pinball includes at least the minimum number of interpolation points (element centers) defined in this value.

Note:

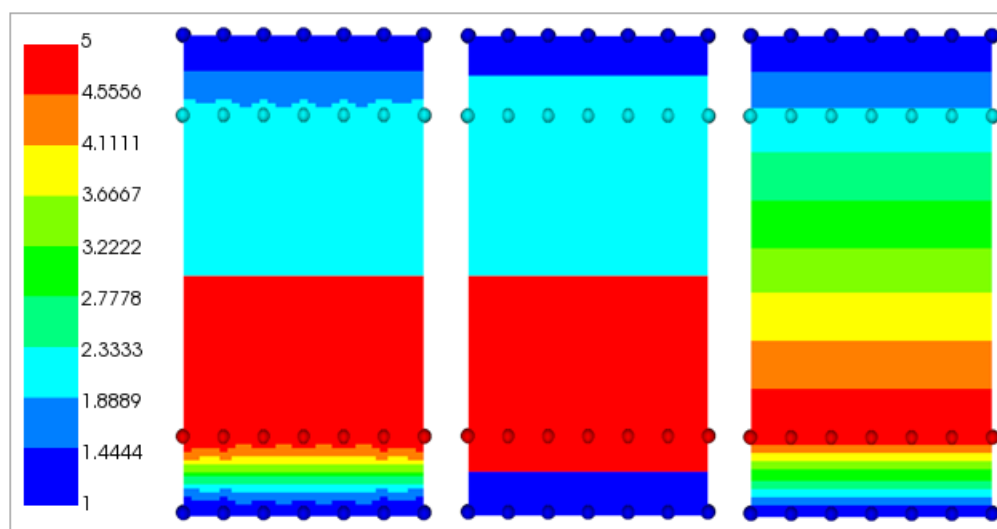
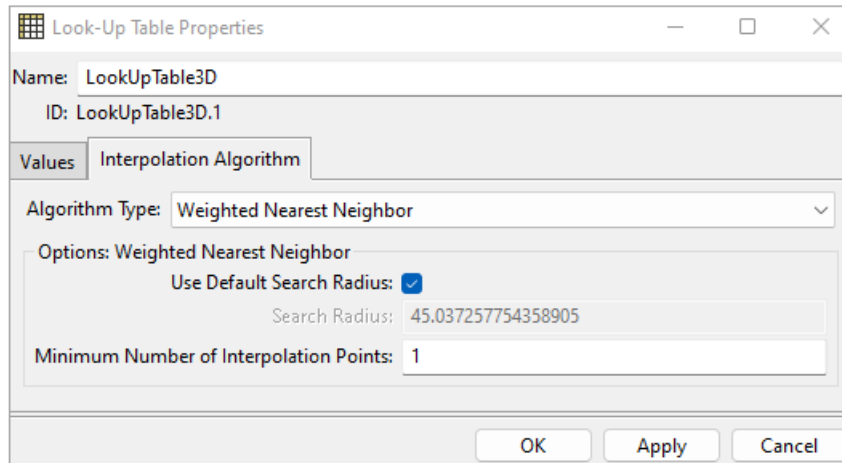
If a 3D Look-Up Table contains points without real numbers (i.e. nan or blank), these values are automatically computed on update by interpolating the valid results.

2.1.7.6. Look-Up Table Column Properties

The dimension of the data columns must be set for unit conversion to work correctly. The column properties can be accessed through the context menu of the column in the Tree View.

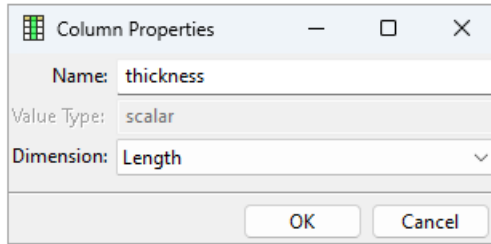
Figure 2.46: Setting the Dimension in the Column Properties Dialog

2.1.8. Selection Rules

Selection Rules enable you to select elements through geometrical operations. These selections can be combined with Oriented Selection Sets (see [OSS Selection Rules \(p. 137\)](#)) or [Modeling Plies \(p. 142\)](#) to define plies of arbitrary shape. The final extension of the ply is the combination of the Selection Rules and the selected Oriented Selection Sets. This feature can be used to define local reinforcements (patches) or staggering. You can select between different selection rule types which are explained in the sections below. It is also possible to combine different rules and to define Boolean operations between rules.

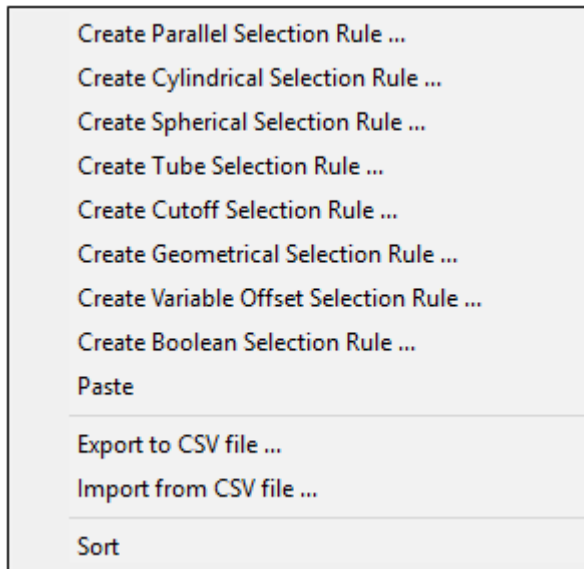
Figure 2.47: Selection Rules Context Menu

The .csv file interface of ACP offers the ability to create or modify selection rules externally, share them with other ACP users working on the same model, or even on a different project. Limitation: The Variable Cut-Off Selection Rule and Boolean Selection Rule are not supported by the CSV interface.

[2.1.8.1. Basic Selection Rules](#)

[2.1.8.2. Tube Selection Rule](#)

[2.1.8.3. Cut-Off Selection Rules](#)

[2.1.8.4. Geometrical Selection Rule](#)

[2.1.8.5. Variable Offset Selection Rule](#)

[2.1.8.6. Boolean Selection Rules](#)

2.1.8.1. Basic Selection Rules

Figure 2.48: Definition of a Parallel Selection Rule

The screenshot shows a dialog box titled "Parallel Selection Rule Properties". It contains the following fields and controls:

- Name:** ParallelRule.1
- ID:** ParallelRule.1
- Parameters:**
 - Use Global Coordinate System:
 - Rosette: [dropdown menu]
 - Origin: (0,0,0)
 - Direction: (1.0000,0.0000,0.0000) with a "Flip" button.
 - Lower Limit: 0.0
 - Upper Limit: 1.0
 - Relative Rule Type:
 - Include Rule Type:
- Buttons: OK, Apply, Cancel

Parallel, **Cylindrical**, and **Spherical** Selection Rules are simple shapes which can be defined by a few parameters:

- **Parallel:** Defined by two parallel planes. The planes are defined by an origin, a normal vector and two distances (offsets of the planes from the origin along the normal vector).
- **Cylindrical:** The cylinder is defined by an origin and the vector of the axial direction and the radius. The cylinder has infinite height.
- **Spherical:** The sphere is defined by the center and the radius.

Figure 2.49: Example of a Parallel Selection Rule

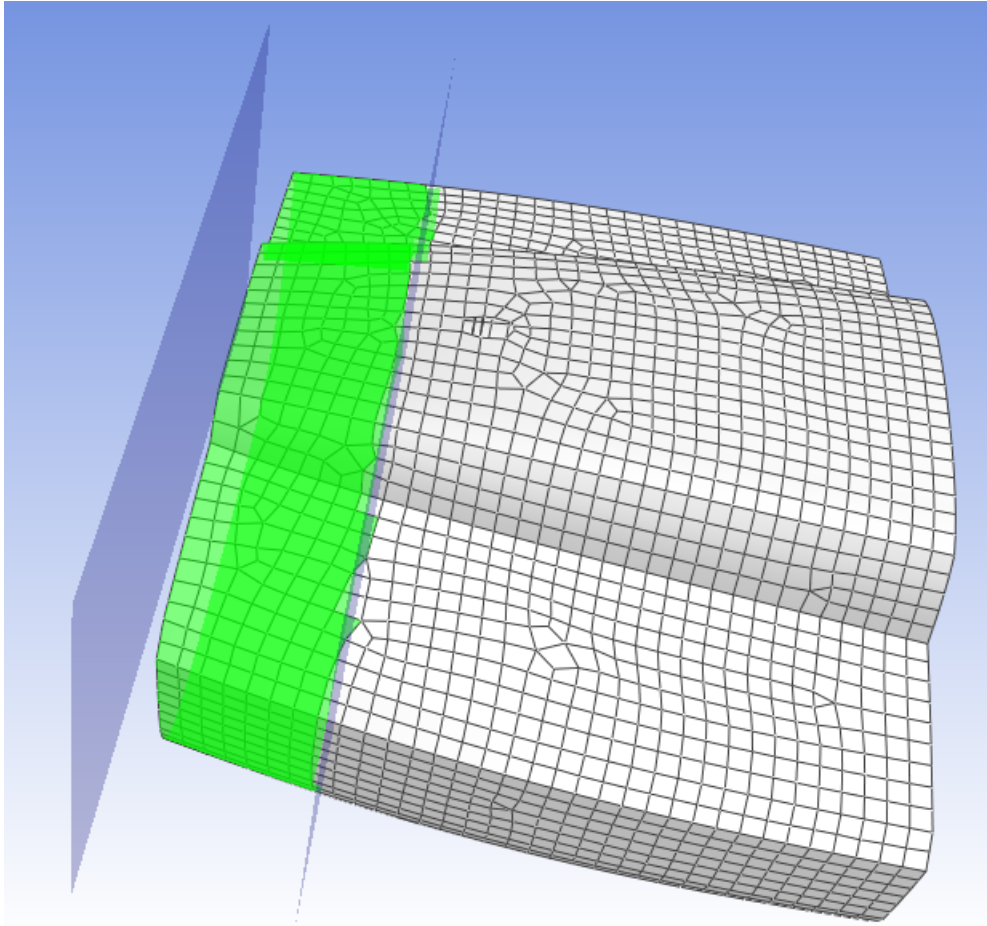

Selection Rule based on Rosettes

Parallel, Cylindrical, and Spherical Selection Rules can be defined in terms of the coordinate relative to a specific Rosette. To choose a Rosette, uncheck "Use global Coordinate System" and select a Rosette from the drop-down menu. If a Rosette is selected, Origin and Direction are in the Rosette's reference frame. Only parallel Rosettes can be used to define Selection Rules.

Relative Selection Rule

It is possible to define a Selection Rule as relative. In this case, the Selection Rule parameters define the ratios of the selection rule relative to the Modeling Ply dimensions. Take care that the Plotted Selection rule is evaluated from the global geometry dimensions and that this plot does not represent the final shape of the Selection Rule which depends on the Modeling Ply. Select the ply and check the highlighted elements which represent the final shape of the ply.

Include Selection Rule

The **Include Selection Rule Type** option can be used to select the elements inside the geometry or outside. By default the option is active (as shown in [Figure 2.49: Example of a Parallel Selection Rule](#) (p. 117)). If the option is inactive, the inverse selection takes effect. Plies with a hole can be created through a **Cylindrical Selection Rule** and disabled **Include Selection Rule Type** option. This option applies to all geometrical rules as well as the **Tube Selection Rule**.

2.1.8.2. Tube Selection Rule

A Tube Selection Rule is a cylinder of variable axial direction with a constant inner and outer radius. The longitudinal direction is defined by an [Edge Set](#) (p. 96), and the radii define the diameters of the inner and outer cylinder. All elements between the inner and outer radius are selected if **Include Rule Type** is enabled (shown below in [Figure 2.51: Tube Selection Rule Properties](#) (p. 119)). Otherwise the inverse selection is used.

Figure 2.50: Example of a tube rule with an outer and inner radius

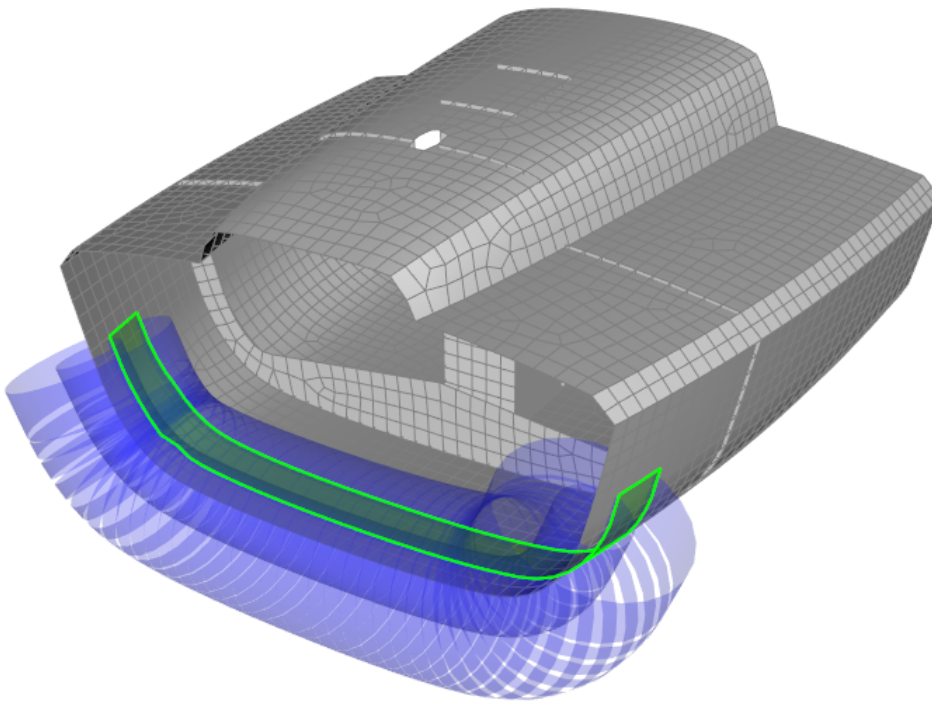

Note: The [Variable Offset Selection Rule](#) (p. 128) allows the definition of a tube with a variable radius.

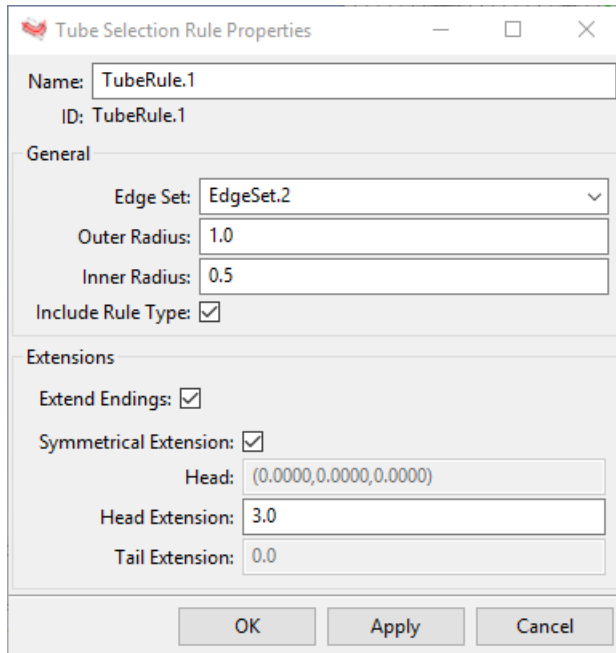
Figure 2.51: Tube Selection Rule Properties

Tube Selection Rule settings are:

- **Edge Set:** Defines the center line (longitudinal direction) of the tube.
- **Outer Radius:** Defines the outer radius of the tube.
- **Inner Radius:** Defines the inner radius of the tube.
- **Include Rule Type:** If enabled (as shown above), elements inside the tube will be selected. If not enabled, elements outside the tube will be selected.
- **Extend Endings:** Enable this option to extend the endings of the tube.
- **Symmetrical Extension:** If enabled, the length of the extensions will be equal on both sides.
- **Head:** The free end which is closer to this point becomes the head of the tube. It is only needed if **Symmetrical Extension** is disabled.
- **Head Extension:** Defines the length of the extension at the head of the tube. If **Symmetrical Extension** is enabled, it defines both sides.
- **Tail Extension:** Defines the length of the extension at the tail of the tube if **Symmetrical Extension** is disabled.

Notes:

- An extension set to zero or a negative automatically disables the feature at the corresponding side.
- When the end of a tube is extended, the extension is oriented in the same direction as the last edge segment.

Figure 2.52: Edge with a long extension at the head of the edge and a short one at the tail

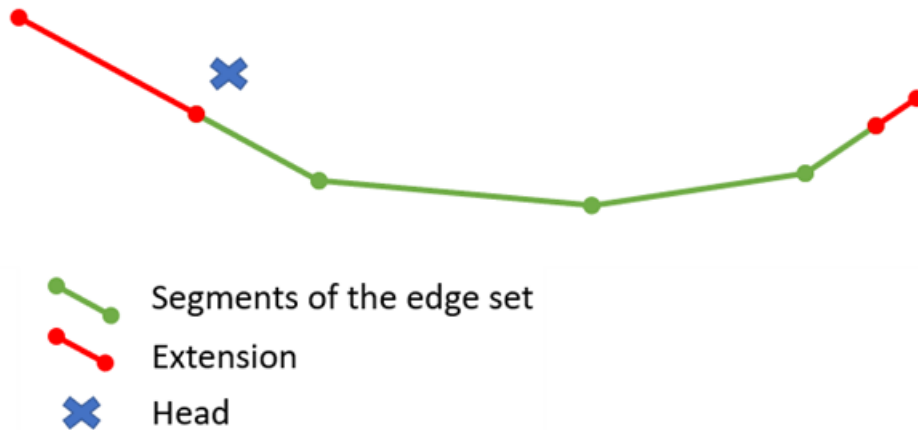

2.1.8.3. Cut-Off Selection Rules

A **Cut-Off Selection Rule** acts as a cutting operation on the composite lay-up. In contrast to other Selection Rules that affect the in-plane directions of the ply, a **Cut-Off Selection Rule** also considers the laminate thickness. A **Cut-Off Selection Rule** can be defined by a geometry or a taper. Using a **Geometry Cut-Off Selection Rule**, the ply is cut at the intersection with a CAD Geometry, taking into account the thickness of the laminate. An example of this is a skew-whiff surface being used to define the tapering near a trailing edge of a blade. A **Taper Cut-Off Selection Rule** cuts plies based on an edge and a taper angle.

Only Analysis Plies are cut off as a result of the selection rule. Modeling and Production Plies are not affected. The **Cut-Off Selection Rule** is similar to a milling operation on built-up structure. In that sense, the full size Modeling and Production Plies are required before the machining operation. The Analysis Plies are the only decisive plies for any structural computation.

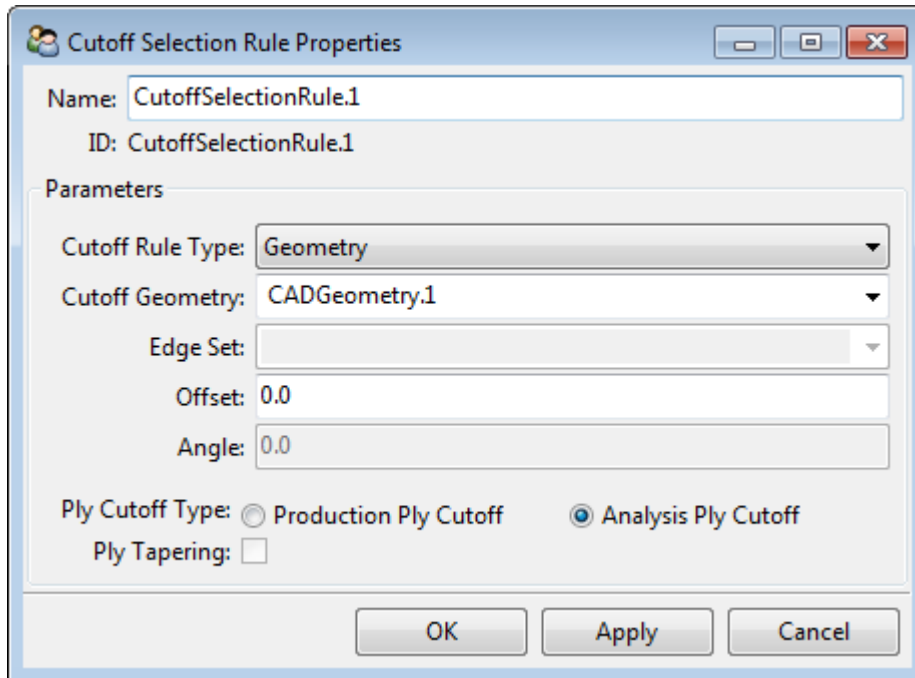
Figure 2.53: Cut-Off Selection Rule Properties

Cut-Off Selection Rule settings are:

- **Name:** Name of the Selection Rule.
- **Cut-Off Geometry:** The CAD geometry defining the Cut-Off.
- **Offset:** CAD / taper surface offset. The intersection of the CAD Geometry/taper edge and the lay-up can be moved by an offset. The direction and orientation of the offset is defined by the normal direction of the Oriented Selection Set.
- **Edge Set:** Selection of an Edge Set (Taper).
- **Angle:** Taper angle (Taper).
- **Ply Cut-Off Type:** Either the complete production ply is cut off or individual analysis plies are cut off. Ply Tapering can only be activated in the latter case.
- [Example Cut-Off \(p. 124\)](#)
- **Ply Tapering:** Control of the Cut-Off resolution.

2.1.8.3.1. Geometry Cut-Off Selection Rule

For each element, ACP determines the position of the ply (including its offset) in relation to the imported surface. There are two possibilities of how the model geometry is cut by a CAD geometry - one cutting operation follows the geometry contour, the other divides the ply into either its maximum thickness or zero thickness. This is controlled by the **Ply Tapering** option in the **Cut-Off Selection Rule Properties** dialog.

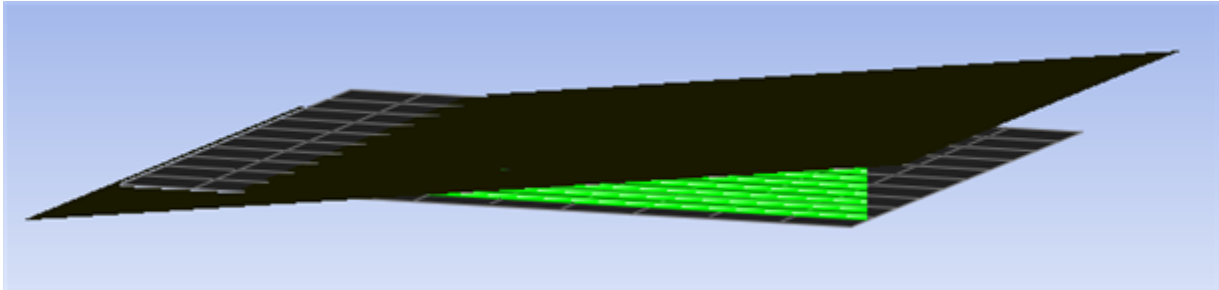
Figure 2.54: Trailing Edge with Cut-Off Plies (Ply Tapering Activated)

In the first method, the ply is cropped if it intersects with the geometry. The ply is cut to match the external geometry.

In the second method, the ply is cut at a discrete point. The ply cannot have a varying thickness - it is either at its maximum thickness or it has been entirely cut off. The ply is cut if the intersection of CAD geometry and ply is less than half of the ply's thickness.

The following figures are taken from [Tutorial 4](#) and are presented to explain the concept further. In the tutorial, a **Geometry Cut-Off Selection Rule** is applied to the core. A section view of the Cut-Off Geometry, applied to two edges, is shown in the figure below. The Cut-Off has a nominal thickness of approximately two thirds of the core thickness and, towards the outside, it has a multi radii edge. The dashed yellow line in the figure denotes the ply's centerline.

Figure 2.55: Section of the Cut-Off Geometry

When **Ply Tapering** is activated, the core is cropped to match the Cut-Off Contour, as shown in the right figure below. If **Ply Tapering** is deactivated, the resulting core thickness is at its full thickness everywhere the intersection of the geometry is above the core centerline. Everywhere else, the core is completely cut off.

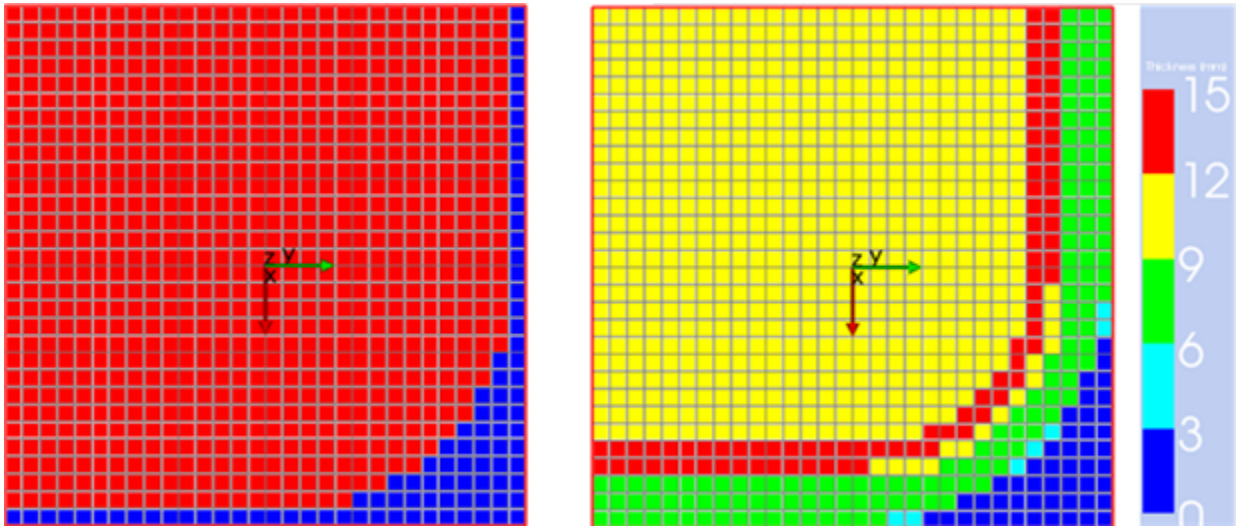
Figure 2.56: Core Thickness Without Ply Tapering (Left) and With Ply Tapering (Right)

2.1.8.3.2. Taper Cut-Off Selection Rule

The second way of using the **Cut-Off Selection Rule** is to define a taper with an Edge Set and a tapering angle. The area close to the edge has to be sufficiently meshed for the taper Cut-Off to work. Similar to the [Geometry Cut-Off](#) (p. 121), the ply is cut off in the taper zone. Only if **Ply Tapering** is selected will there be a gradual taper over thickness. The Taper Cut-Off Selection Rule allows the same definition as the **Taper Edges** feature for modeling plies. For a detailed explanation of taper angle and offset, see [Edge Tapering](#) (p. 269).

By default, ACP analyzes the Cut-Off selection rule at the element centers. Each element is cropped from the ply if the ply thickness at the element center is negative. This binary representation may not be sufficiently accurate in certain cases. If the [Use Nodal Thickness](#) (p. 65) is enabled, the Cut-Off and ply tapering (if enabled) will be refined, which in turn results in a more accurate model. For more information, see [Element- vs. Node-based Thicknesses](#) (p. 68).

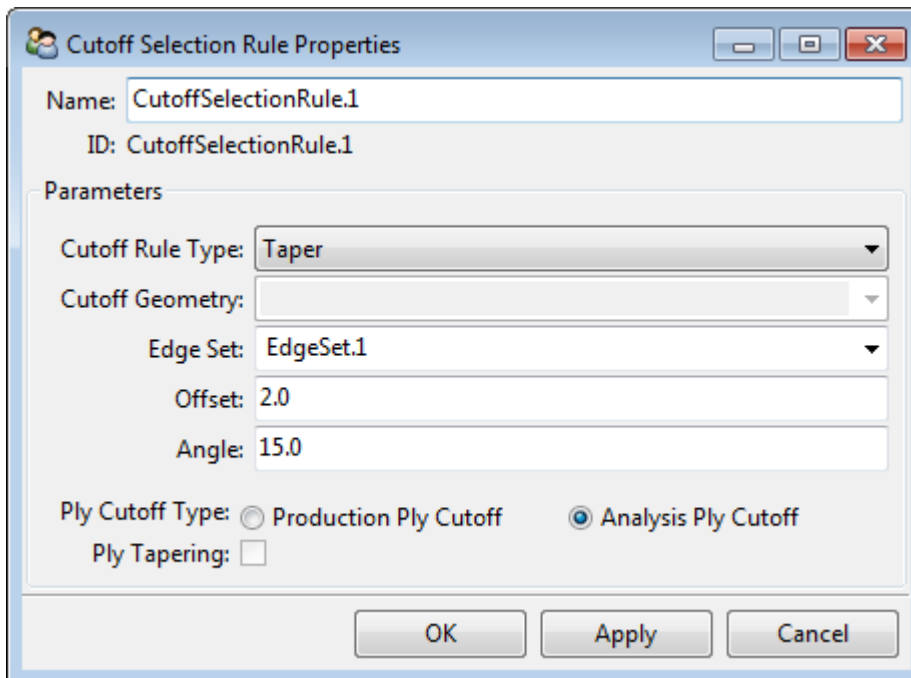
Figure 2.57: Taper Cut-Off Selection Rule Definition

2.1.8.3.3. Example Cut-Off

Consider a Stackup of three Fabrics for this example. In the pictures below, a laminate of one Stackup is shown marked with the green lines. The blue lines highlight the Analysis Plies of the Stackup. The black lines represents the mesh and the red line indicates the final laminate resulting from the **Cut-Off Selection Rule**.

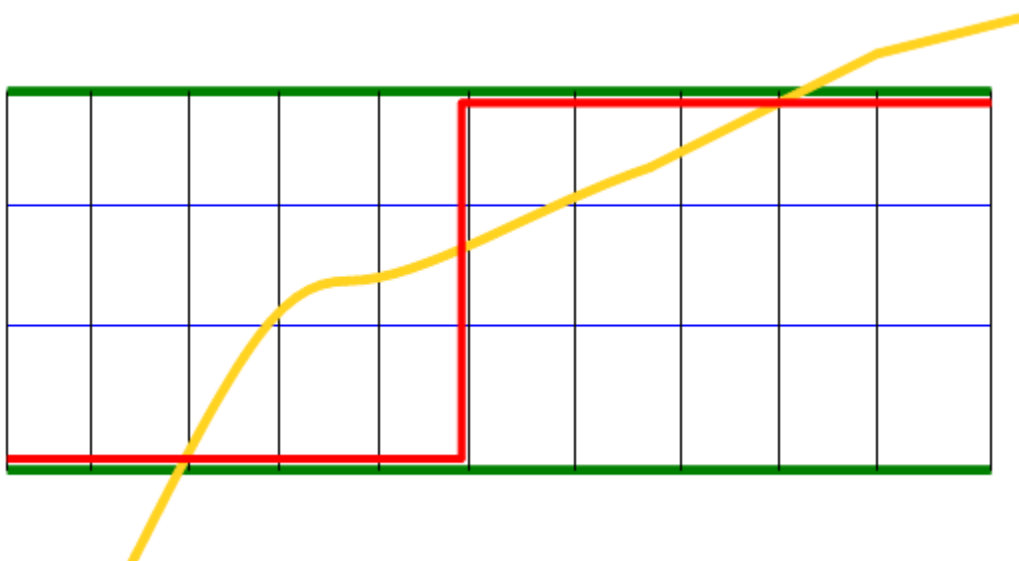
Figure 2.58: Section with The Production Ply Option

The **Cut-Off Selection Rule** with the **Analysis Ply Cut-Off** option will result in a smoother section as each Analysis Ply of the Stackup is cut individually.

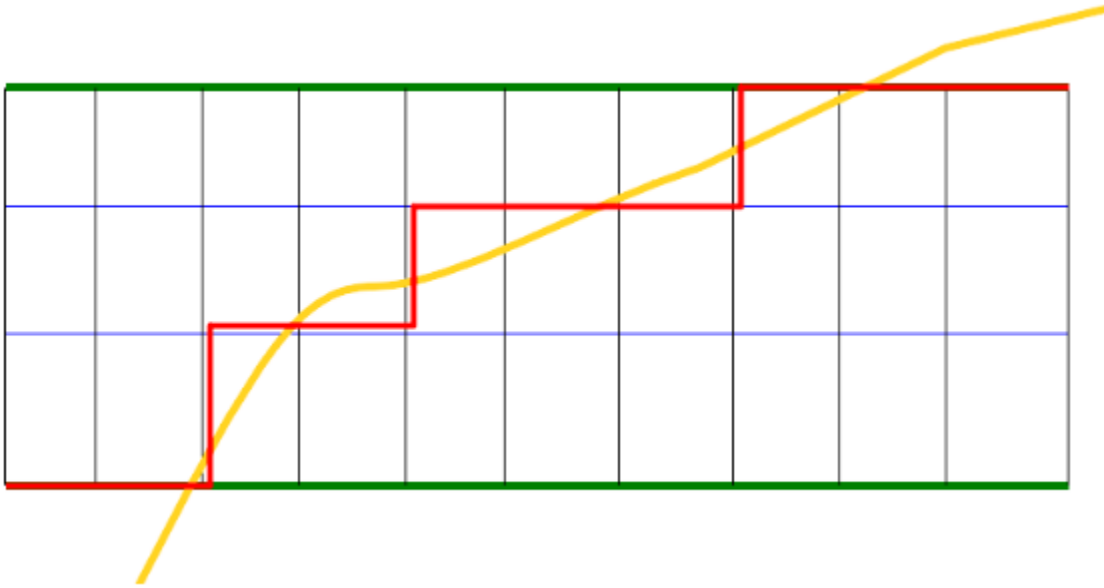
Figure 2.59: Section with the Analysis Ply Option

The **Cut-Off Selection Rule** with **Ply Tapering** will result in an even smoother section. The ratio between the area of the section cut by the CAD Geometry and the uncut section is calculated. The same ratio is applied to the ply thickness for the considered element.

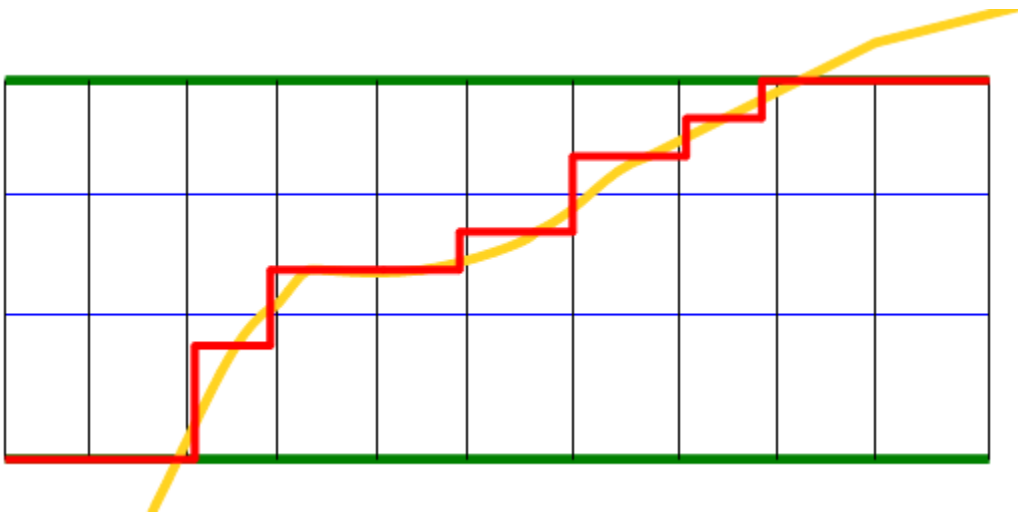
Figure 2.60: Section with the Analysis Ply with Tapering Option

2.1.8.4. Geometrical Selection Rule

The Geometrical Selection Rule allows you to define the extent of a modeling ply or OSS based on a CAD surface or solid geometry. Elements are selected if they lie within the enclosure of a defined volume. The volume is set by the size of the CAD solid geometry or the CAD surface geometry in combination with specified Capture Tolerances. This means that a flat CAD surface geometry can be used to define a ply on a curved mesh surface. [Figure 2.61: Example Geometrical Selection Rule \(p. 126\)](#) shows a selection inside a curved mesh enclosed by a flat surface with relatively high negative and positive capture tolerances. See [CAD Geometries \(p. 99\)](#) for information on how working with geometries impacts system performance.

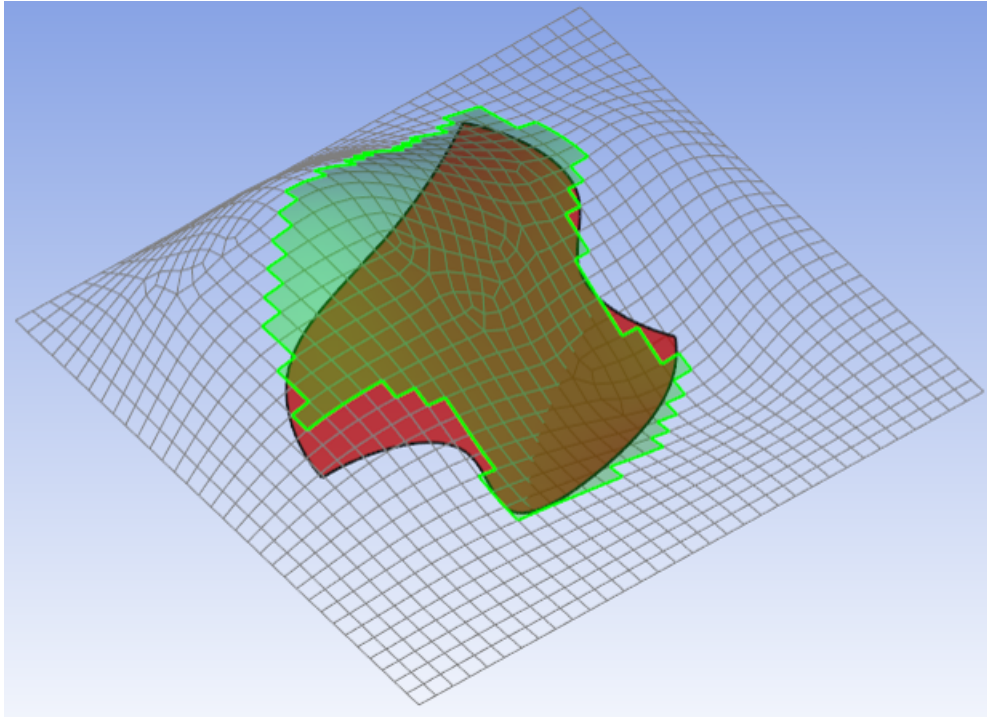
Figure 2.61: Example Geometrical Selection Rule

Geometrical Selection Rules have the following settings:

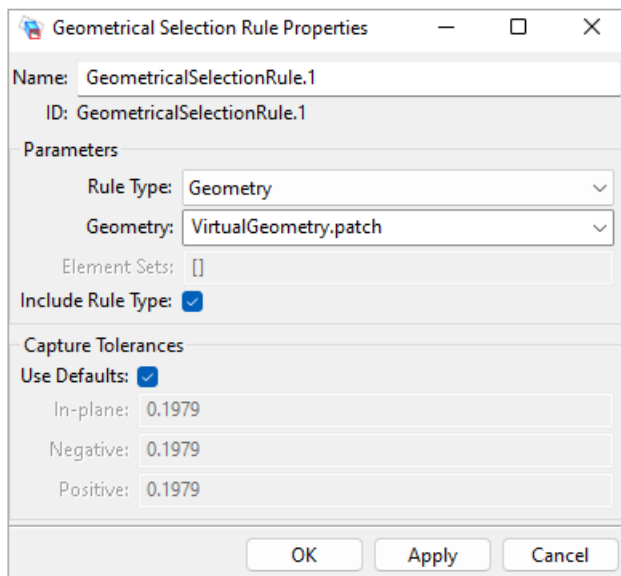
Figure 2.62: Geometrical Selection Rule Properties

- **Rule Type:** Define whether the rule extent is defined by a geometry of Element Sets. The value can be **geometry** or **element_sets**. The default is setting is **geometry**.
- **Geometry:** [Virtual Geometry \(p. 101\)](#) defining the basic selection (only relevant for Rule Type: Geometry).
 - Geometry:

Virtual Geometries (p. 101)

defining the basic selection (only relevant for Rule Type: Geometry).

- **Element Sets:** Preselection of elements in the form of an Element Set where the rule is applied on (only relevant for Rule Type: Element Sets). Multiple Element Sets can be parsed as input by holding the [Ctrl] button while making your selections.
- **Include Rule Type** (p. 117)

Capture tolerances are necessary for non-solid geometries, such as surfaces. They evaluate whether a point is within the geometry by creating an envelope as shown below. The unit values are in length. All three tolerances support negative values.

- **Use Defaults:** Defines if the default value is used. The default value is the Offset property of the [CAD geometry \(p. 99\)](#).
- **In-plane:** Increase the in-plane extension of the geometry by this value. A negative value will shrink the surface.
- **Negative:** Capture tolerance in the reverse direction of the surface normal. A negative value offsets the geometry in the surface normal direction.
- **Positive:** Capture tolerance in the direction of the surface normal. A negative value offsets the geometry in the opposite direction of the surface normal.

The in-plane tolerance can also be adjusted on the Modeling Ply level by template rule parameters. This may be useful when defining ply tapering. For more information, see [Selection Rules \(p. 145\)](#).

Note:

In principle, the in-plane tolerance is used to extend to the boundary of the geometry. It is also used to fill gaps between adjacent surfaces that may cause sampling issues. Therefore, it is recommended to use an **In-plane** tolerance > 0 when the selection is missing some elements inside the capturing geometry.

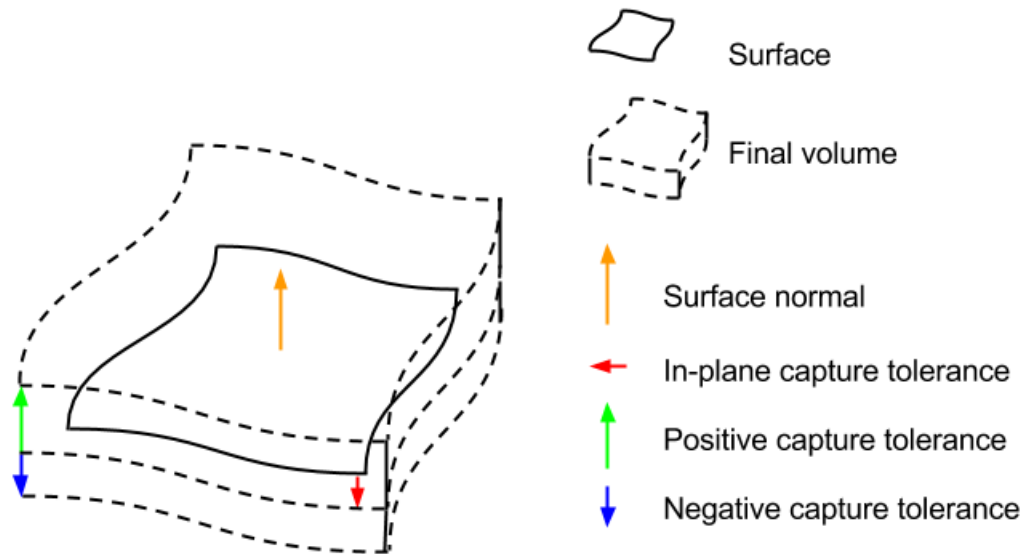
Figure 2.63: Capture Tolerances

2.1.8.5. Variable Offset Selection Rule

The Variable Offset Selection Rule is defined on the basis of an Edge Set and a 1-D Look-Up Table containing a list of offsets at different locations. Elements adjacent to the Edge Set are selected if their centroids lie within the specified offset at the given locations. The offsets are linearly interpolated between locations. In this way, the rule behaves like an advanced Tube Selection Rule where the outer radius can be varied.

There are two different ways in which the Look-Up Table data can be interpreted: the location of each offset can be mapped on to a direction vector (default), or on to the length of the Edge Set.

The rule is not called the variable radii rule is because you can define the offset over a curved surface defined by an Element Set. The offsets are initially evaluated as a radius at each element adjacent to the Edge Set. The Offset Correction then adjusts the offset so that the offset is measured over the curvature of the surface.

The template rule functionality is not available for the Variable Offset Selection Rule; however there is a way to accommodate ply staggering with this rule. In addition to the offsets, varying ply taper angles can also be defined in the form of a 1-D Look-Up Table. Ply Tapering can be used when multiple Modeling Plies share the same Variable Offset Selection Rule. In such cases, the first Modeling Ply will cover the area defined by the offset definition. The subsequent plies will be tapered based on the angle definition. The tapering is applied not on the Edge Set side, but on the offset side, away from the Edge set.

Note:

The angle definition can be used to decrease, fix, or increase the covered areas of the subsequent Modeling Plies.

Complex patch shapes can be realized with the help of this selection rule.

Figure 2.64: Look-Up Table Defines the Offset to Edge Set at a Given Length

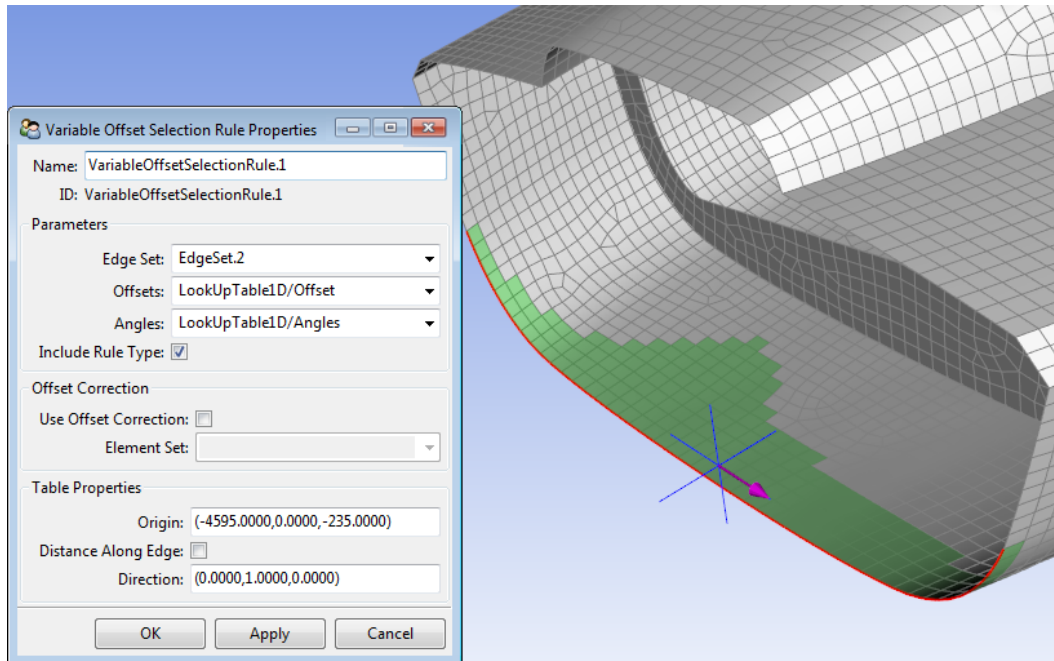

Parameters

- **Edge Set:** The offsets are measured along this Edge Set.
- **Offsets:** 1-D Look-Up Table with a list of offsets at different locations.
- **Angles:** (optional) 1-D Look-Up Table with a list of angles at different locations. Only active when same rule is applied to multiple Modeling Plies. Does not affect the first Modeling Ply. Depending on the local angle, the covered area of the subsequent plies is changed.
 - Angle equals 90 deg: Plies are not changed.
 - Angle less than 90 deg: Ply coverage decreases with number of modeling plies.
 - Angle greater than 90 deg: Ply coverage increases with number of modeling plies.
- **Include Rule Type:** The selection envelope can be inverted with this option.

Offset Correction

Figure 2.65: Offset Correction

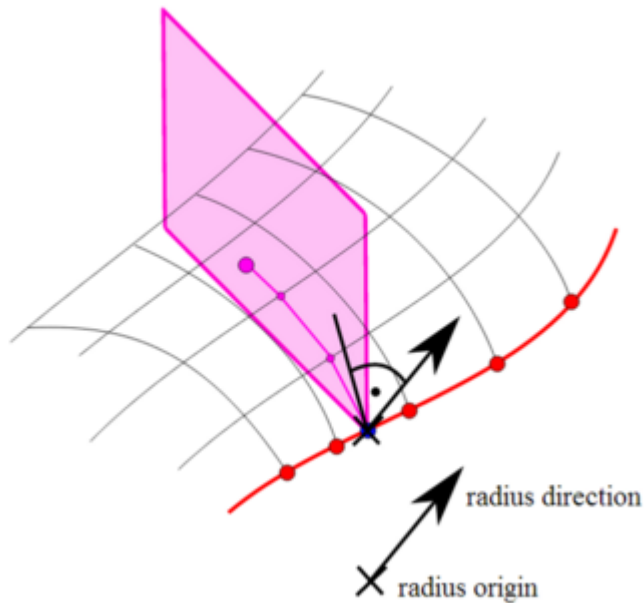

- **Use Offset Correction:** The offset is measured along the surface curvature of the selected Element Set in a segmented arc when this option is active.
- **Element Set:** The offset correction is calculated on the curvature of this Element Set. The selection rule can be applied to other Element Sets also, but retains the offset correction.

Table Properties

Figure 2.66: Offset Mapping Along a Direction Vector

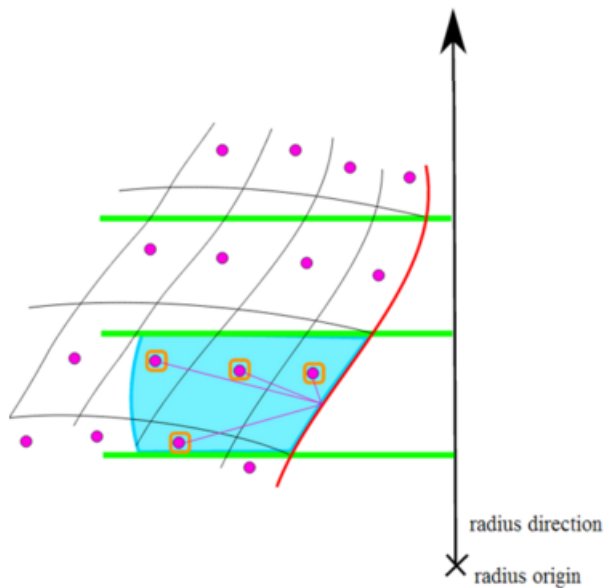

- **Origin:** This replaces the origin in the 1-D Look-Up Table definition.

- **Direction:** This replaces the direction in the 1-D Look-Up Table definition.
- **Distance Along Edge:** When active, the 1-D Look-Up Table data is mapped along the distance of the Edge Set. In this case, the origin is used to determine the start and the end of the Edge Set. The mapping will start at the corner of the edge which is closest to the origin. The zero location in the Look-Up Table coincides with the start of the selection rule.

2.1.8.6. Boolean Selection Rules

The Boolean Selection Rule enables you to combine rules based on Boolean operations. Supported operators are **Intersect**, **Add**, and **Remove**. (See the dialog below in [Figure 2.67: Boolean Selection Rule \(p. 131\)](#).) The order you apply the rules is important because they are processed as sequential filters. Each Boolean operation is applied to the previous intermediate result. Also, because the first rule applies to all shell elements, using the **ADD** operator in the first rule will have no effect.

Template Rules: You can redefine some Selection Rule parameters in the Boolean Selection Rule definition. Set the **Template** (A, below) to True for those selection rules that should be treated as a template rule, and then set the values manually. The same feature can be applied to Modeling Plies. Details are documented in [Modeling Ply - Selection Rules \(p. 145\)](#).

Figure 2.67: Boolean Selection Rule

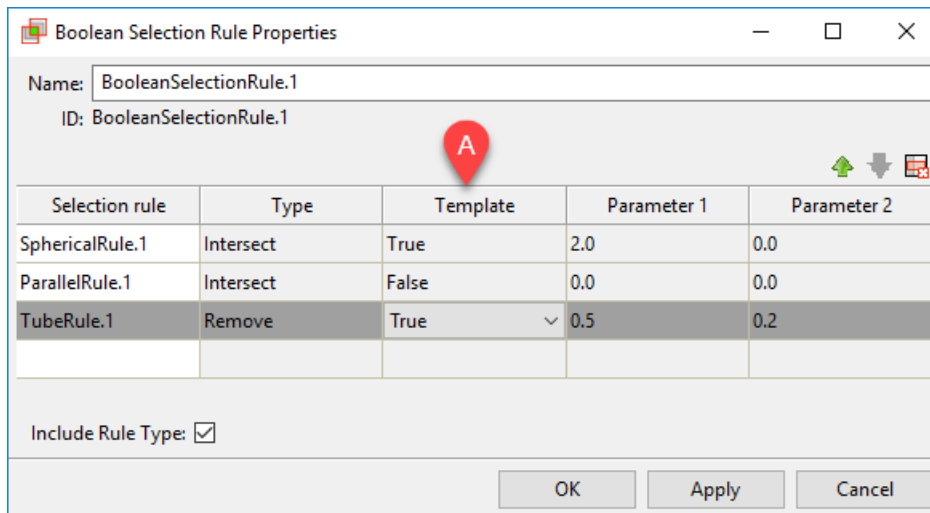
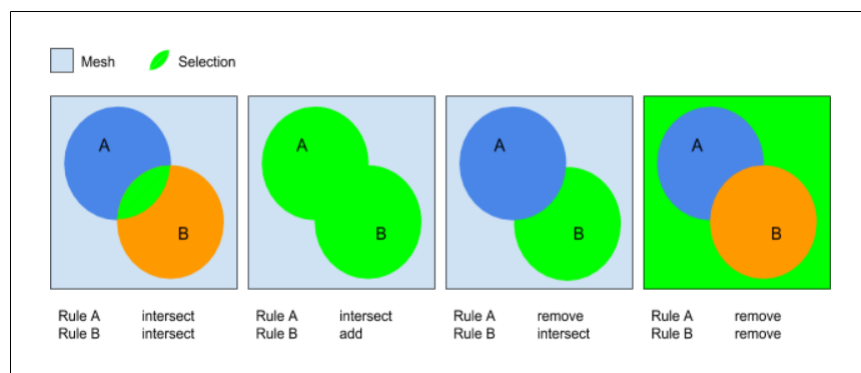

Figure 2.68: Boolean Operation Types



Note the following limitations:

- Cut-Off Selection and other Boolean Rules cannot be used within a Boolean Selection Rule.
- The CSV interface does not support Boolean Selection Rules.

2.1.9. Oriented Selection Sets (OSS)

Oriented Selection Sets (OSS) are a key concept in ACP.

The OSS define the basis for the lay-up definition. Plies are applied on Oriented Selection Sets and not on Element Sets. The OSS give you an independence from your finite element model and its element normals. OSS combine the following important entities for your composite lay-up:

- The **area** that plies are applied to.
- The **orientation**, or side of the shell mesh on which the plies are applied.
- The **reference direction** defining the 0° fiber direction. All ply angles are relative to this direction.

The Selection Rules, defined in the Rules tab, can further control the area of an OSS. You may also use the draping algorithm, in the Draping tab, to define the reference direction on the OSS.

The following figure shows an example of an Orientation Point selected on the mesh and pointing outwards. The section cut indicates that the lay-out is built in the outwards direction.

Figure 2.69: Orientation Point Definition

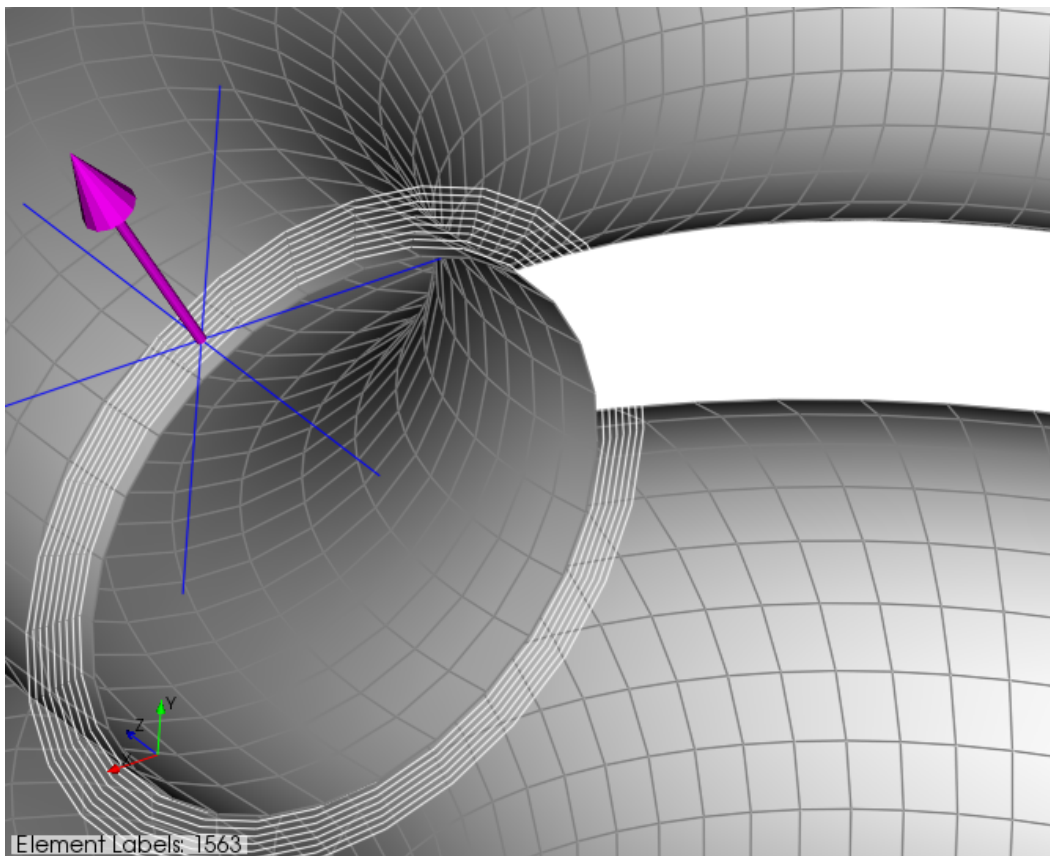
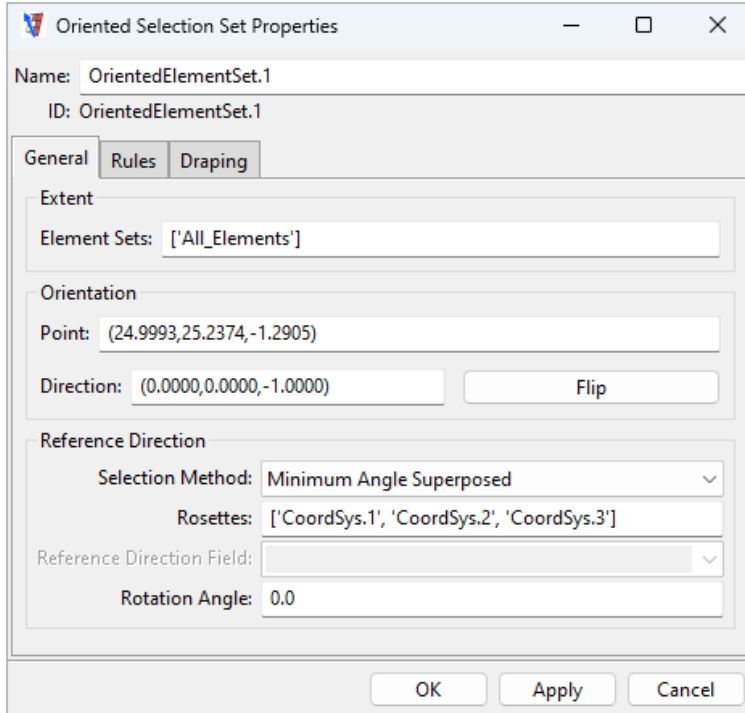

Figure 2.70: Definition

An Oriented Selection Set is defined by:

- **Name:** Name of the OSS.
- **Element Sets:** Underlying elements for the OSS definition
- **Orientation Point:** Offset direction is defined at this point. The point should be inside and close to the reference surface, otherwise the mapping of the offset direction can result in wrong results.
- **Orientation Direction:** Vector defining the offset (normal) direction at the **Orientation Point**.
- **Reference Direction:** Defines the 0° direction of the OSS.
 - **Selection Method:** Defines the mapping algorithm for the Rosettes if more than one Rosette is used. For more information, see [Reference Direction \(p. 134\)](#).
 - **Rosettes:** One or more Rosettes defining the Reference Direction for each element through the selected method.
 - **Reference Direction Field:** Defines the direction column of a 3D Look-Up Table. Only applicable to the tabular values method.
 - **Rotation Angle:** Angle (in degrees) to rotate the Reference Direction around the Orientation Direction. For more information, see [Use Cases for Rotation Angle \(p. 135\)](#).

Use the **Flip** button to reverse the offset direction.

2.1.9.1. Reference Direction

The Reference Direction can be defined by Rosettes or from tabular values. A single Rosette is sufficient for the definition of the Reference Direction. Multiple Rosettes can be selected for one Oriented Selection Set to obtain complex Reference Direction definition. In this case, a **Selection Method** must be used to determine which Rosette is applicable to what part of the Element Set. The **Selection Method** offers several interpolation algorithms listed below:

Ansys Classic
Maximum Angle
Maximum Angle Superposed
Minimum Angle
Minimum Angle Superposed
Minimum Distance
Minimum Distance Superposed
Tabular Values

- **Ansys Classic:** Coordinate system is projected on the elements as defined in Ansys (see [Coordinate Systems](#)).
- **Maximum Angle:** Coordinate system in which the Z direction has the maximum angle with the element orientation defines the Reference Direction of the Oriented Selection Set.
- **Maximum Angle Superposed:** Same as **Maximum Angle** but all the chosen coordinate systems are considered and weighted by the maximum difference angle direction.
- **Minimum Angle:** Coordinate system in which the Z direction has the minimum angle with the element orientation defines the Reference Direction of the Oriented Selection Set. (default)
- **Minimum Angle Superposed:** Same as **Minimum Angle** but all the chosen coordinate systems are considered and weighted by the minimum difference angle direction.
- **Minimum Distance:** Nearest coordinate system of the element defines the Reference Direction of the Oriented Selection Set
- **Minimum Distance Superposed:** Same as **Minimum Distance** but all the chosen coordinate systems are considered and weighted by the distance to the element.
- **Tabular Values:** Interpolated from the values put in a [Look-Up Table](#) (p. 107). The table must include the location values and a direction column.

Note:

If the determination of an element's Reference Direction fails, an alternate computation method is used and a warning is issued. In this case, it is recommended to verify the Reference Directions of the affected Oriented Selection Set.

The bonding laminates of the [T-Joint](#) example are a case where a **Minimum Angle Selection Method** is suitable.

Figure 2.71: Reference Direction of a Bonding Laminate Defined by Two Rosettes and a Minimum Angle Selection Method

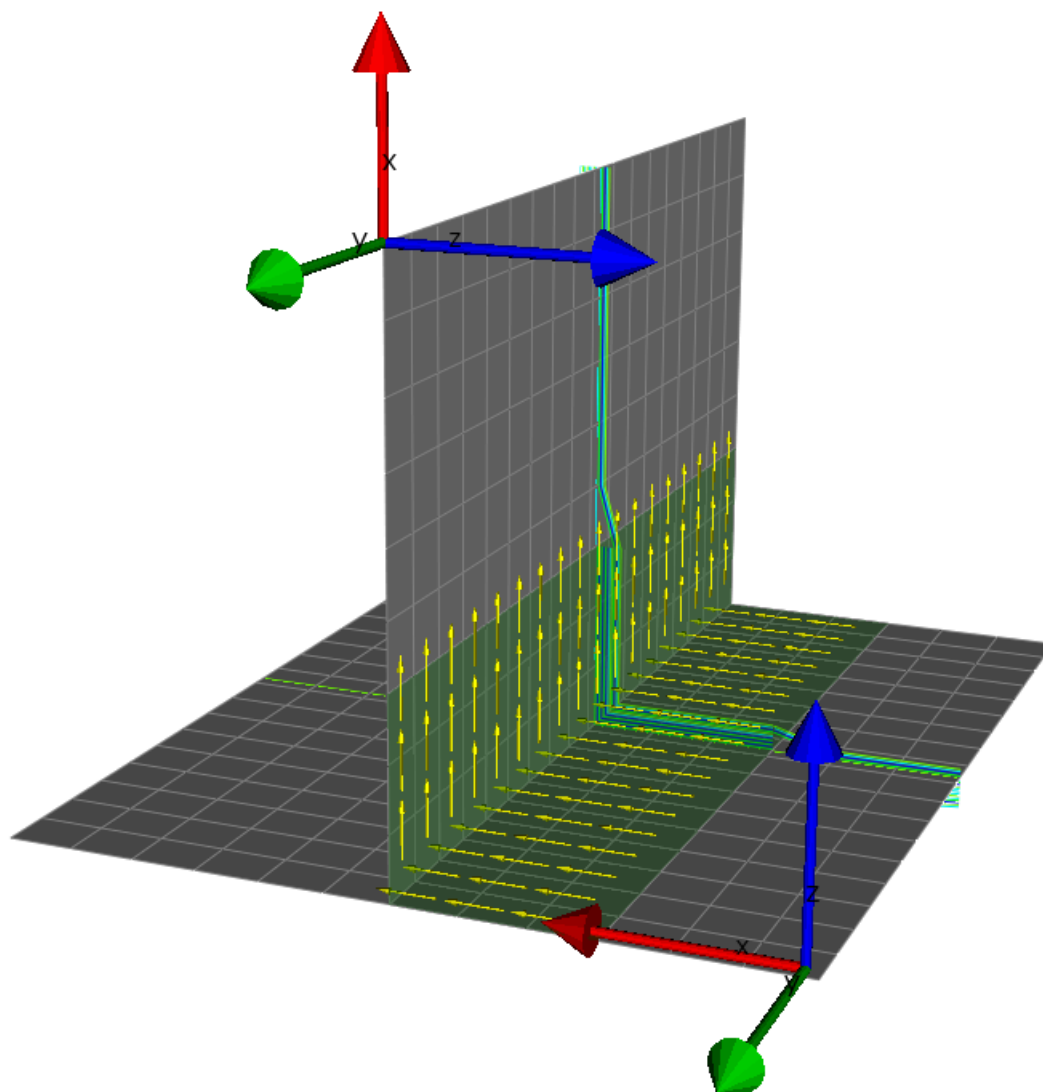

2.1.9.1.1. Use Cases for Rotation Angle

Reference Directions Perpendicular to Edges

Edge-wise Rosettes (p. 103) can define a Reference Direction along an edge as shown in the left model in [Figure 2.72: Reference Directions Along an Edge and Perpendicular to an Edge \(p. 136\)](#). To create a Reference Direction perpendicular to an edge as shown in the right model, you may use the same Rosettes and set the **Rotation Angle** to **90.0** degrees as shown below.

Reference Direction	
Selection Method:	Minimum Distance Superposed
Rosettes:	['Rosette.1', 'Rosette.2']
Reference Direction Field:	
Rotation Angle:	90.0

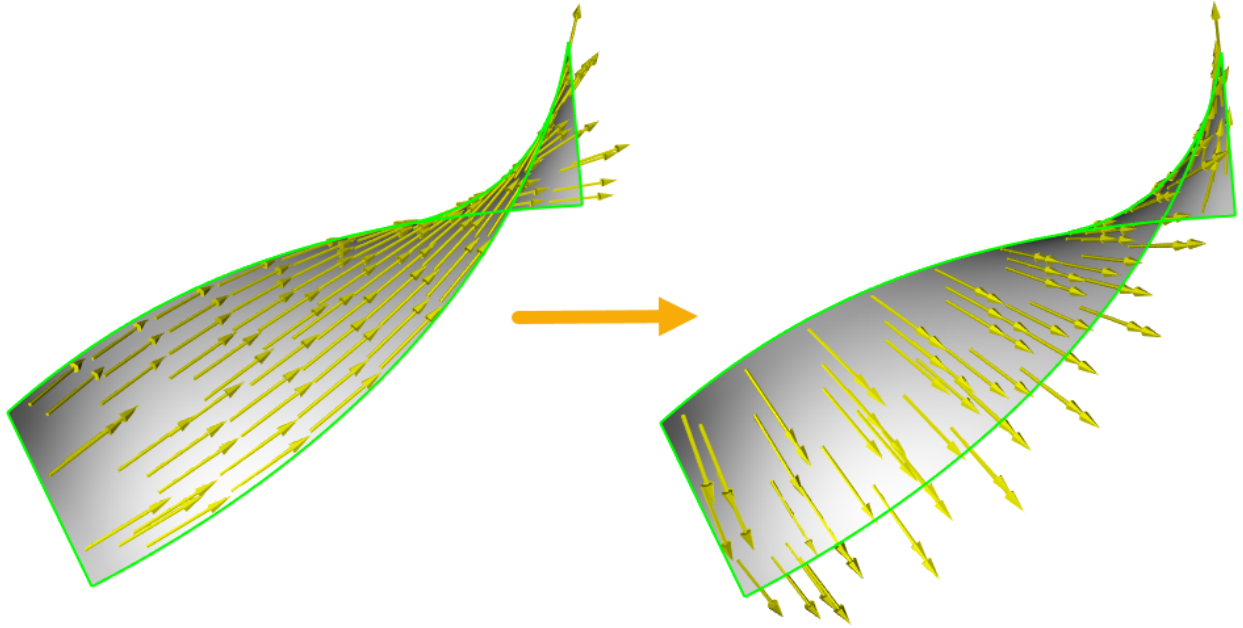
Figure 2.72: Reference Directions Along an Edge and Perpendicular to an Edge

Axial Reference Directions

You may also use Rotation Angle to define a Reference Direction parallel to the axis of an axisymmetric structure as shown in [Figure 2.73: Axial Reference Direction \(p. 137\)](#). In this case, define the initial Reference Direction using a cylindrical Rosette and rotate it by 90 degrees as shown below.

Reference Direction	
Selection Method:	Minimum Angle <input type="text"/>
Rosettes:	['Cylindrical Rosette']
Reference Direction Field:	<input type="text"/>
Rotation Angle:	90.0

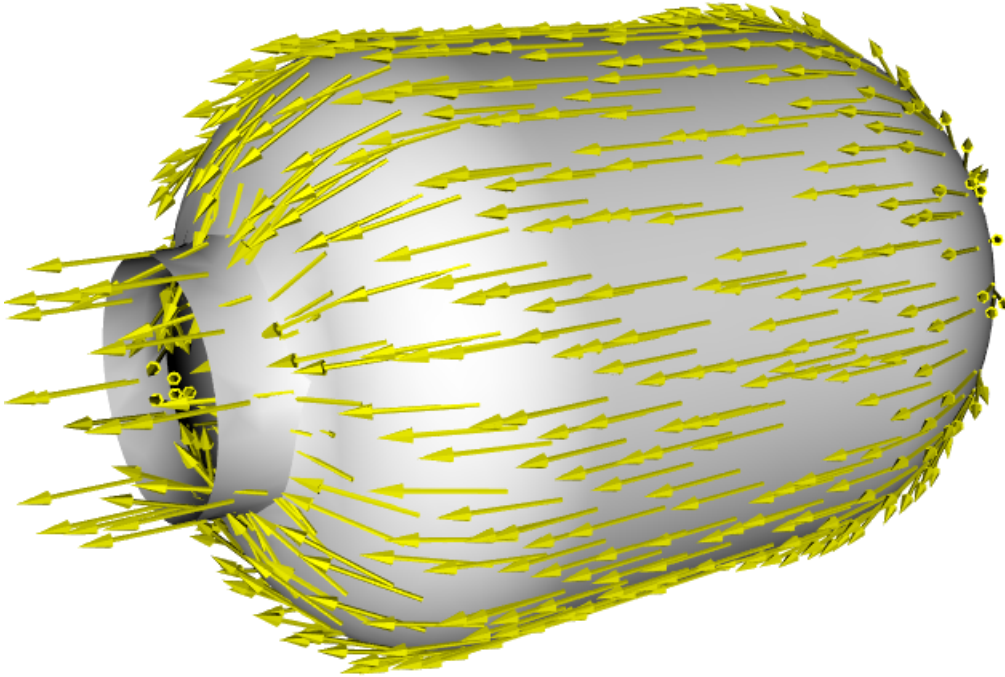
Figure 2.73: Axial Reference Direction

2.1.9.2. Selection Rules

The OSS can be intersected with one or several Selection Rules. The intersection of all selected entities ([Element Sets \(p. 95\)](#) and [Selection Rule \(p. 115\)](#)) defines to new extension of the OSS.

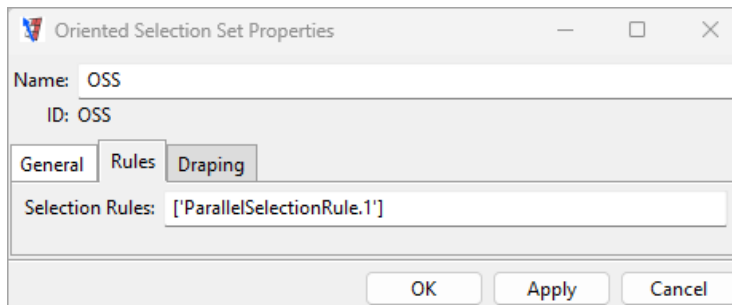
Figure 2.74: Selection Rules

Note:

Although the [Cut-Off Selection Rules \(p. 120\)](#) use the lay-up definition to calculate the cut location, this Selection Rule has no influence in this case.

2.1.9.3. Draping

If the **Draping** option is activated, the reference direction of the Oriented Selection Set is adjusted and all associated modeling plies use this draped reference direction. Note that the model property

Use Draping Offset Correction doesn't have any effect on the OSS draping. For more information about draping, see [Draping \(p. 279\)](#) and [Draping Simulation in the *Composites Theory Reference*](#).

Figure 2.75: Draping

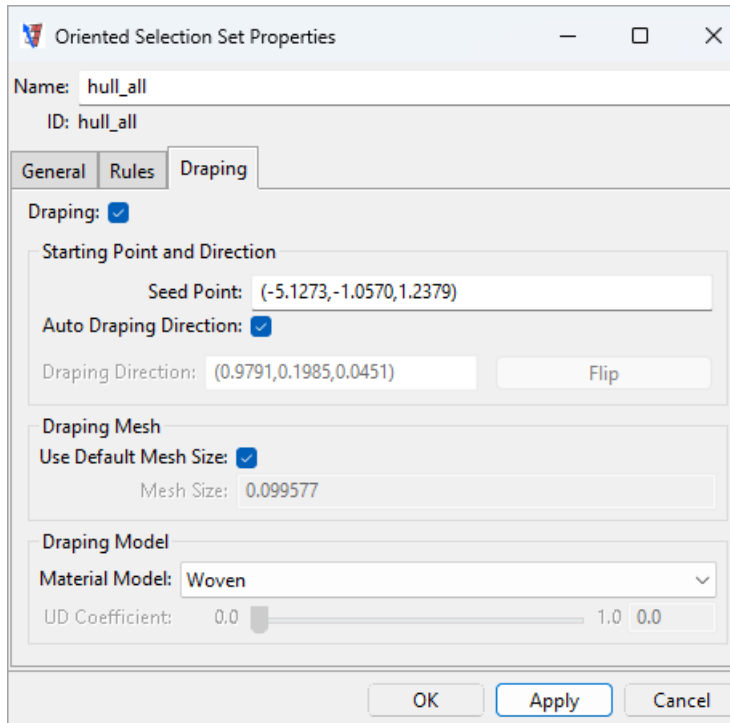

The following parameters control the Internal Draping of the OSS:

- **Seed Point:** Starting point of the draping process.
- **Auto Draping Direction:** Uses the reference direction of the oriented selection set.
- **Draping Direction:** Sets the primary draping direction for the draping scheme. The secondary direction is always orthogonal to the primary.
- **Use Default Mesh Size:** Enable this property to use the default size for the draping mesh. The default size is the average element size of the shell mesh.
- **Mesh Size:** A user-defined mesh size for the draping mesh can be set if **Use Default Mesh Size** is disabled.
- **Material Model:** The material model used in the draping simulation, either *Woven* (default) or *Unidirectional*.
- **UD Coefficient:** A parameter between 0 and 1 that controls the amount of deformation in the transverse draping direction. This property is active only when **Material Model** is set to *Unidirectional*.

For more information on the Draping feature, see [Draping Algorithm](#) and its [Limitations](#).

2.1.10. Modeling Groups

The ply definition can be organized into Modeling Groups. These Groups do not affect the ply-ordering and definition, but they provide a way for you to better organize Composite Definitions and streamline your workflow. For example, you might choose to define one Ply Group for each substructure of a boat project- one for the hull, one for the deck, and one for the bulkhead.

Before working with a Modeling Group, you must specify an Oriented Selection Set and a Material (Fabric, Stackup, or Sublaminated). Within a Modeling Group, plies can be created. The lay-up is defined as it would be in production. The first ply is also first in the stacking sequence. The lay-up can be tailored by specifying the Orientation, Layering, geometrical Selection Rules, Draping Settings, and Edge Tapering for each ply.

A lay-up can also include an Interface Layer for carrying out a fracture analysis of a composite solid model in Mechanical. The interface layer is a separation layer in the stacking sequence, used to analyze the crack growth of existing cracks. The crack topology is defined with an interface layer in ACP while all other fracture settings are specified in Mechanical. The interface layers are exported as [INTER204](#) or [INTER205](#) elements and can be used to set up a Cohesive Zone Model (CZM) or a Virtual Crack Closure Technique (VCCT) analysis. They can also be used to define contact zones between two layers. For more information, see [Interface Delamination and Contact Debonding](#) in the *Mechanical User's Guide*.

Lay-ups can also be defined or changed using the [Excel Link interface](#) (p. 24). Changes can also be made by [importing or exporting the lay-up as a CSV file](#) (p. 258).

2.1.10.1. Modeling Group Structure

The **Modeling Group** node has three sub-levels:

- **Modeling Ply (MP):** The ACP lay-up is defined at this level. The other two levels are built automatically from information defined in this level.
- **Production Ply (PP):** Production Plies are generated derived from the **Modeling Ply** definition (**Material** and **Number of Layers**). A Fabric and Stackup is one **Production Ply**. A Sublaminated typically contains more than one **Production Ply**. In addition the **Number of Layers** option is also propagated to this level.
- **Analysis Ply (AP):** The analysis plies describe the plies used in the section definition for the Ansys solver. A Fabric results in one **Analysis Ply**. A **Production Ply** without an **Analysis Ply** indicates that the resulting **Analysis Ply** contains no elements and is therefore not generated.

In the example below, there are three different MP separated by one interface layer:

- **ModelingPly 1:** Defined with a single Fabric
- **ModelingPly 2:** Defined with a Stackup of two Fabrics
- **ModelingPly 3:** Defined with a Sublaminated containing three production plies (Stackup, Fabric, Stackup), which results in five analysis plies.

The interface layer lies between the second and third modeling plies.

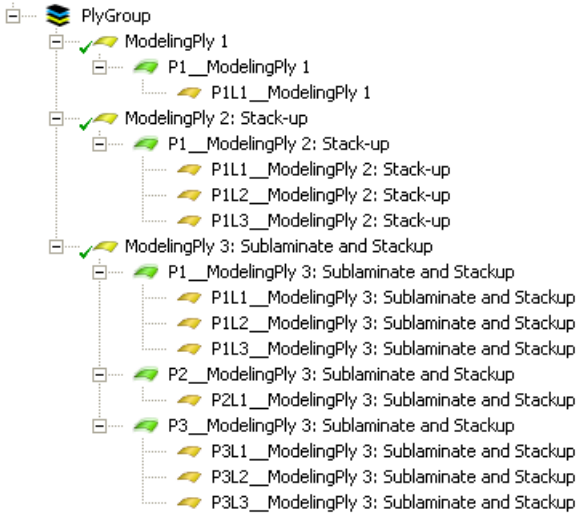
Figure 2.76: Object Tree of a Lay-Up Definition

You can easily navigate through the ply definition with a shortcut. Use the square brackets keys ([and]) to move up and down through the plies.

Modeling Plies can be reordered or moved between Modeling Groups using cut-and-paste or drag-and-drop. See [Reordering Modeling Plies, Interface Layers, and Butt Joint Sequences \(p. 155\)](#) for details.

2.1.10.2. Modeling Group Tree Object Context Menu

The context menu of Modeling Group in the top level of the object Tree contains the following options:

- **Create Modeling Group:** Create a Ply Group with the default name.
- **Create Imported Modeling Group:** Create an Imported Ply Group with the default name.
- **Export to CSV file:** Export all plies with all modeling ply definitions to a .csv file (see [Import from / Export to CSV File \(p. 157\)](#)).
- **Import from CSV file:** Import plies from a .csv file (see [Import from / Export to CSV File \(p. 157\)](#)).

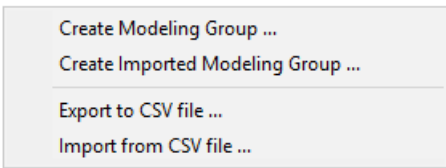
Figure 2.77: Context Menu of Modeling Groups

2.1.10.3. Individual Modeling Group Context Menu

The context menu of an individual Modeling Group has these options:

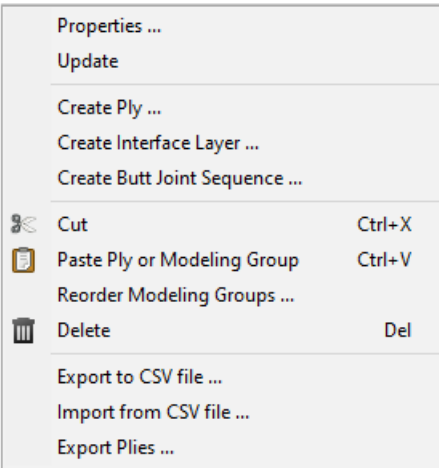

- **Properties:** Display the **Modeling Ply Properties** dialog.
- **Create Ply:** Create and define a new ply.
- **Create Interface Layer:** Create and define an interface layer for fracture analysis.
- **Create Butt Joint Sequence:** Create and define a new butt joint sequence.
- **Update:** Update the model until all Modeling Plies of this group are up-to-date.
- **Paste Ply or Modeling Group:** Paste objects from the clipboard.
 - If any Plies, Interface Layers, or Butt Joint Sequences are on the clipboard, paste them into the selected Modeling Group.
 - Otherwise, paste Modeling Groups from the clipboard after the selected Modeling Group.

See [Reordering Modeling Plies, Interface Layers, and Butt Joint Sequences \(p. 155\)](#) for details on how cut-and-paste affects the Global Ply Number.

- **Reorder Modeling Groups:** Move the selected Modeling Group(s) before or after another group. Note that the order of the Modeling Groups does *not* affect the stacking sequence. The stacking sequence is based on the Global Ply Number and the Orientation of the [Oriented Selection Set \(p. 132\)](#).
- **Delete:** Delete the selected Modeling Group.
- **Export to CSV file:** Export the whole Modeling Group with all modeling ply definitions to a `.csv` file (see [Import from / Export to CSV File \(p. 157\)](#)).
- **Import from CSV file:** Import a Modeling Group from `.csv` file (see [Import from / Export to CSV File \(p. 157\)](#)).
- **Export Plies:** Export the ply offset geometry as a `.STP`, `.IGES`, or `STL` file (see [Export Ply Geometry \(p. 158\)](#)).

2.1.10.4. Modeling Ply Properties

The following properties are needed for a Modeling Ply definition:

Figure 2.78: General Information

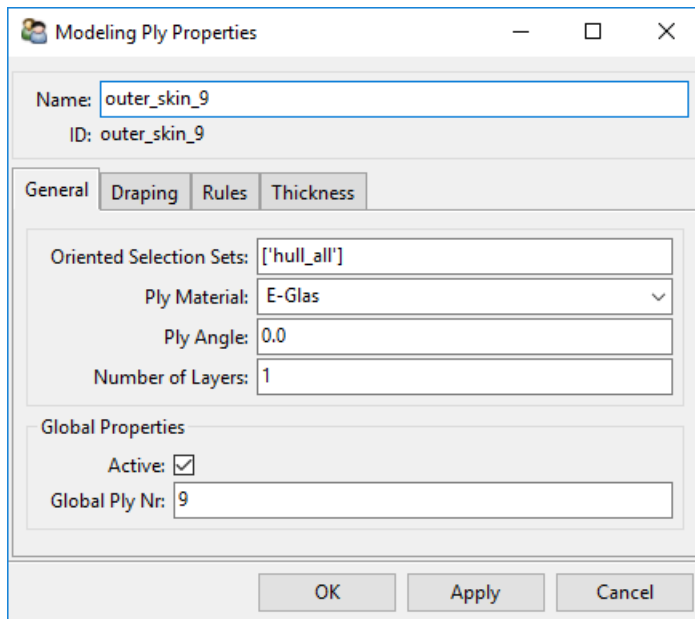

- **Name:** Name of the Modeling Ply.
- **Oriented Selection Sets:** Defines the offset and material direction.
- **Material:** Modeling Ply Material (Fabric, Stackup or Sublamine).
- **Ply Angle:** The design angle between the reference direction and the ply fiber direction.
- **Number of Layers:** Number of times the plies are generated.
- **Active:** Active plies are considered in an analysis, inactive plies are present but not considered.
- **Global Ply Nr:** Defines the global ply order. Per default a new Modeling Ply is added after the last Modeling Ply of the Modeling Group. The order of the Modeling Plies in the Modeling Groups is equal to this value.

2.1.10.4.1. Draping

Consider the draping effects during the production process in the lay-up definition. The draping approach can be specified in the **Draping** tab of the **Modeling Ply Properties** dialog. The following types of draping are available:

- **No Draping** (default)
- **Internal Draping:** The draped fiber directions are determined by the internal ACP draping algorithm.
- **Tabular Values:** Draped fiber directions are interpolated from a Look-Up Table.

The parameters for **Internal Draping** and **Tabular Values** are explained below.

Note:

Draping can also be assigned to an [Oriented Selection Set \(OSS\)](#) (p. 137). In this case, the Reference Direction of the OSS is adjusted. All associated modeling plies use this draped reference direction. This avoids running multiple draping simulations on the same surface. If **Internal Draping** is applied to a modeling ply associated with a draped OSS, then an independent draping simulation is started for the Modeling Ply.

Internal Draping

The following parameters control the **Internal Draping**:

- **Seed Point:** Starting point of the draping process.
- **Draping Direction:** Sets the primary draping direction for the draping scheme. The secondary direction is always orthogonal to the primary.
 - **Auto Draping Direction:** Uses fiber direction of the production ply.
 - **User-Defined Direction:** Uses the defined vector.
- **Default Mesh Size:** Enable this property to use the default size for the draping mesh. The default size is the average element size of the shell mesh.
- **Mesh Size:** A user-defined mesh size for the draping mesh can be set if **Default Mesh Size** is disabled.
- **Thickness Correction:** The thickness of the draped ply is corrected based on the shearing (see [Thickness Correction in the Composites Theory Reference](#)).

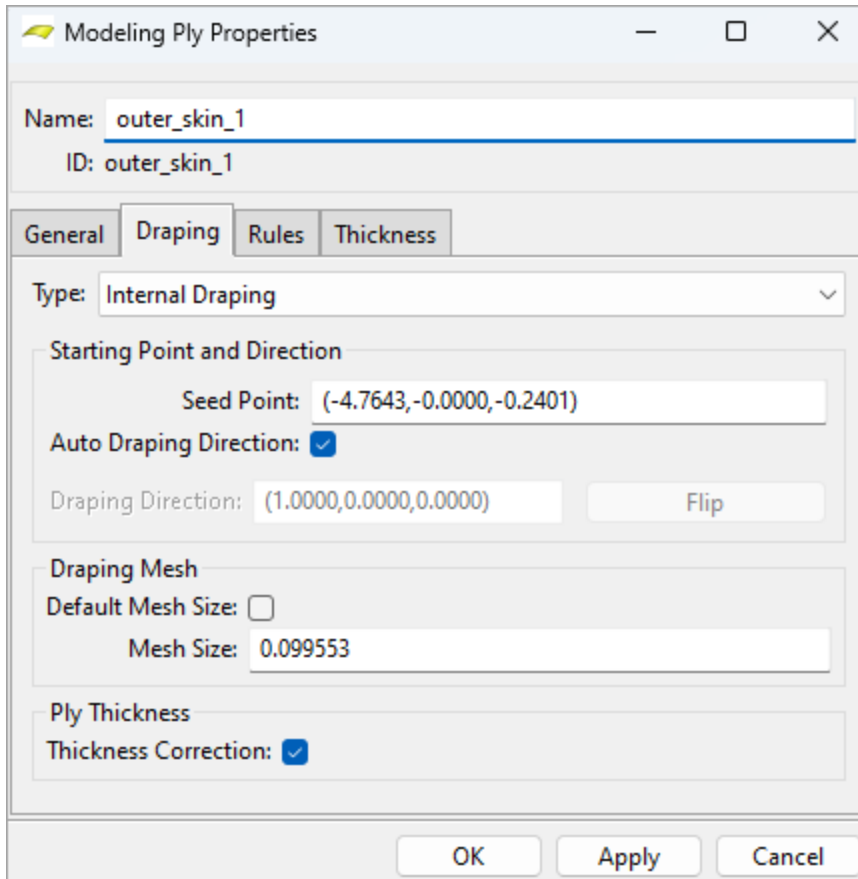
Figure 2.79: Internal Draping Definition

For more information on the Draping feature, see [Draping Algorithm](#) and its [Limitations](#).

Tabular Values

The tabular value draping options lets you choose the draped fiber directions from vectors in a Look-Up Table:

- **Correction Angle 1:** Sets the draped fiber direction.
- **Correction Angle 2:** Sets the draped transverse direction.

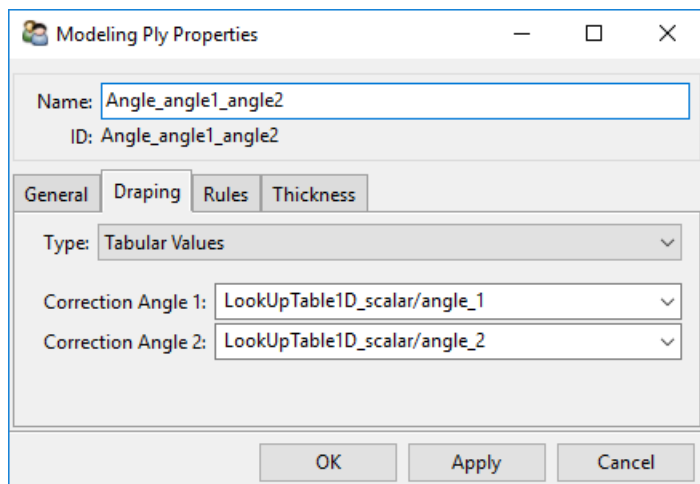
Figure 2.80: Draping with Tabular Values Definition

2.1.10.4.2. Selection Rules

Like in the definition of an Oriented Selection Set, a Modeling Ply can have one or more [Selection Rules](#) (p. 115). The combination of all [Element Sets](#) (p. 95) and active [Selection Rules](#) (p. 115) defines the extension of the Modeling Ply. Each rule has its own Boolean operator (intersect, add, or remove) which allows you to define arbitrary combinations of rules (see [Boolean Operation Types](#) (p. 131)).

Template Rules

In addition, the Selection Rule parameters can be redefined in the Modeling Ply definition. This prevents the same Selection Rule from being defined multiple times and allows staggering to be defined with a single Selection Rule. In the Rules tab, activate Template as True for those selection rules that have to be treated as template rule and set the values.

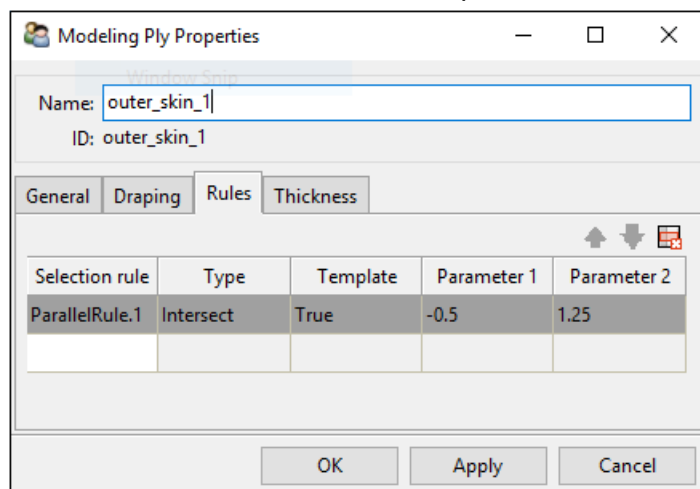

The template parameters for each selection rule type are given in the table below:

Rule Type	Parameter 1	Parameter 2
Parallel Selection Rule	Lower Limit	Upper Limit
Tube Selection Rule	Outer Radius	Inner Radius
Cylindrical Selection Rule	Radius	-
Spherical Selection Rule	Radius	-
Cut-Off Selection Rule	-	-
Geometrical Selection Rule (Geometry)	In-plane capture tolerance	-
Variable Offset Rule	-	-
Boolean Selection Rule	-	-

2.1.10.4.3. Thickness

The thickness of the ply is defined by default by the thickness of the ply material.

Figure 2.81: Thickness Definition

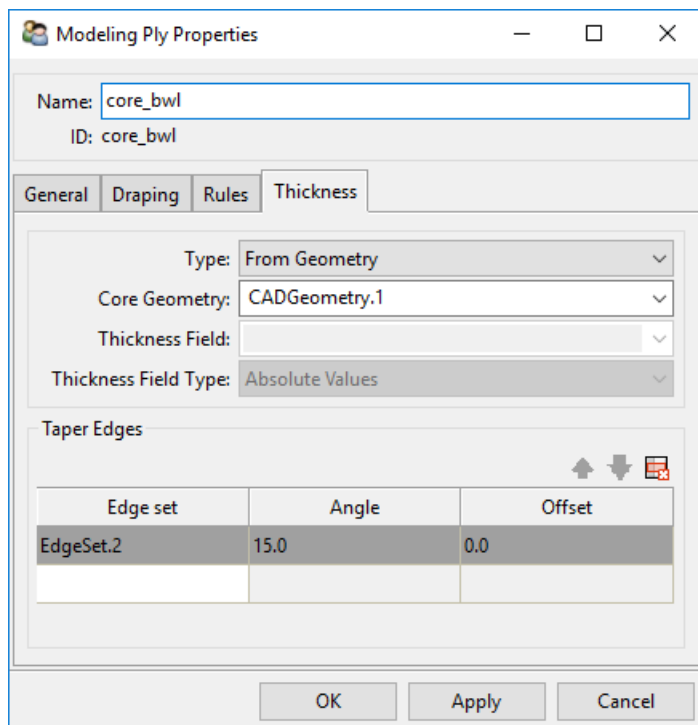

For Fabrics the ply thickness can also be defined by a CAD Geometry or Tabular Values. The thickness options are:

- **Type:** Thickness definition method.

Figure 2.82: Thickness Definition Options

Nominal
From Geometry
From Table

- **Nominal:** The thickness defined in Fabrics is used for the thickness definition.
- **From Geometry:** [CAD Geometry \(p. 97\)](#) calculates the thickness. In the case of a complex core ply, it can be helpful to work with a CAD Geometry defining the thickness distribution of the core. ACP samples through the CAD Geometry for each element and maps the thickness. The thickness is evaluated in the element normal direction.

Figure 2.83: Core Geometry

Figure 2.84: Resulting Section Cut

- **From Table:** A data field evaluates the thickness. ACP inter- or extrapolates the thicknesses for each element. One data point contains the global coordinates and the thickness values. The values in the table can be used as absolute or relative thickness. See [Look-Up Tables \(p. 107\)](#) for more information on how to define this table.
- **Core Geometry:** Thickness of the CAD geometry is mapped to the mesh.
- **Thickness Field:** Thickness is determined by mapping a value field to the mesh.
- **Thickness Field Type:**
 - **Absolute Values:** Values in the Look-Up Table define the thickness.
 - **Relative Scaling Values:** Values in the Look-Up Table are scaling factors.
- **Taper Edges:** adds an edge tapering to the selected Edge Set.

Core plies are commonly tapered along the boundary. The **Taper Edges** option allows you to define a taper angle and a taper offset for each edge. The figure below shows a 15 degree tapering along the edge on the left. The thickness is 0 at the selected edge and grows with the specified angle. The **Taper Edges** option is intended for applying a taper angle to a single ply, for example, a core material. When applied to multiple Modeling Plies the thickness distributions of all plies are superposed. For more information, see [Edge Tapering \(p. 269\)](#) and [Tapering of Multiple Plies \(p. 272\)](#).

Figure 2.85: Edge Tapering**Figure 2.86: Taper Edge Example**

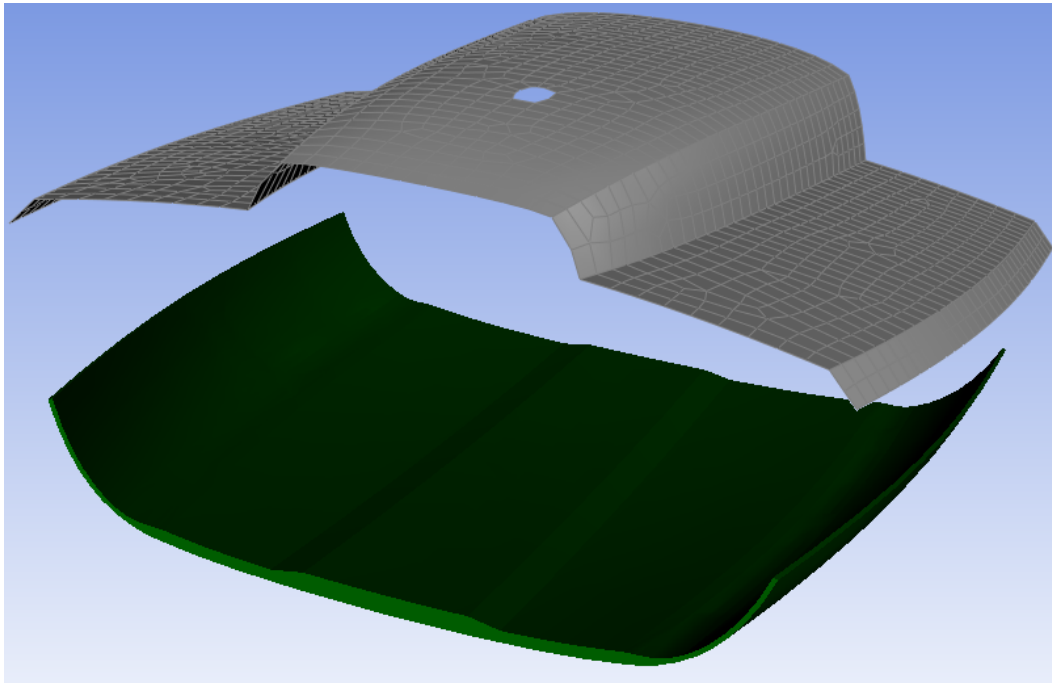
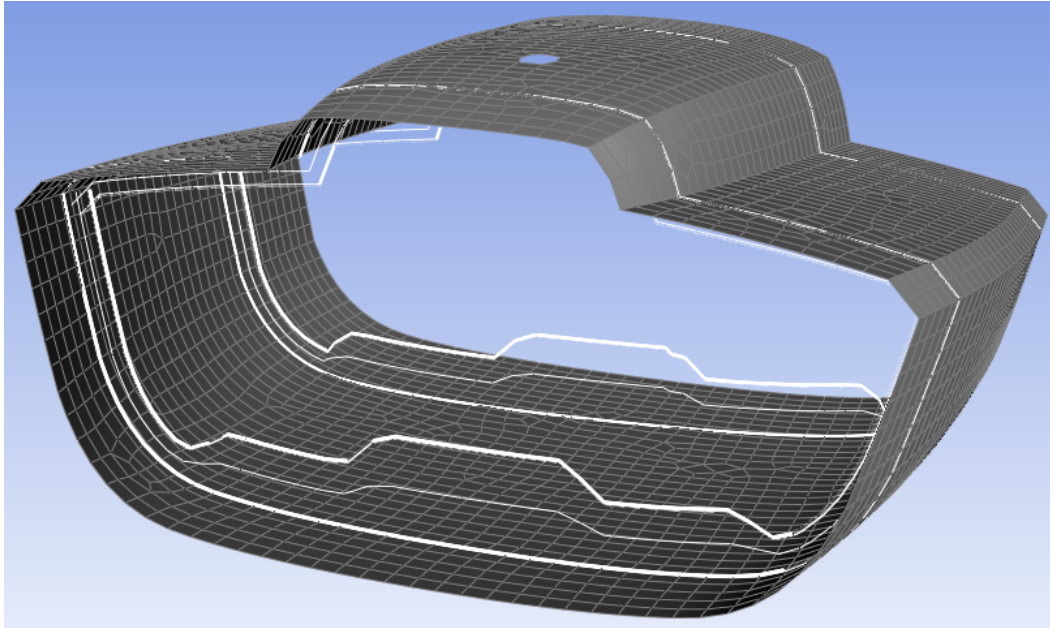
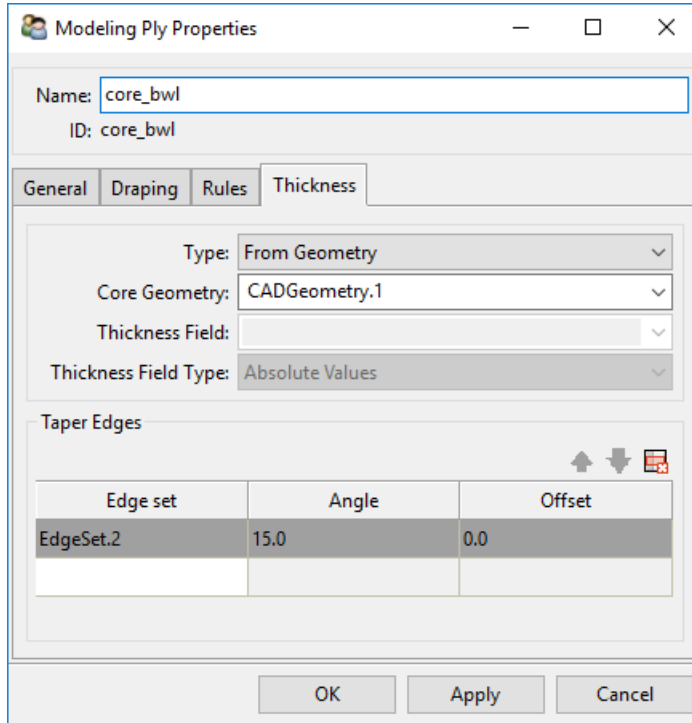
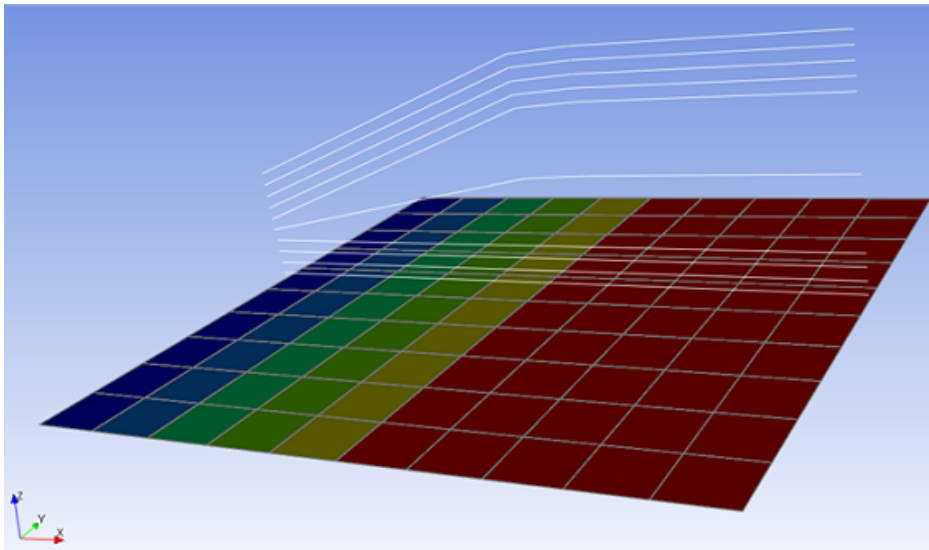
By default, ACP analyzes ply tapering at the element centers. Each element is cropped from the ply if the ply thickness at the element center is negative. This binary representation may not be sufficiently accurate in certain cases. If the [Use Nodal Thickness \(p. 65\)](#) is enabled, the ply tapering will be refined, which results in a more accurate model. For more information, see [Element- vs. Node-based Thicknesses \(p. 68\)](#).

2.1.10.4.4. Modeling Ply Context Menu

The context menu for Modeling Ply has the following options:

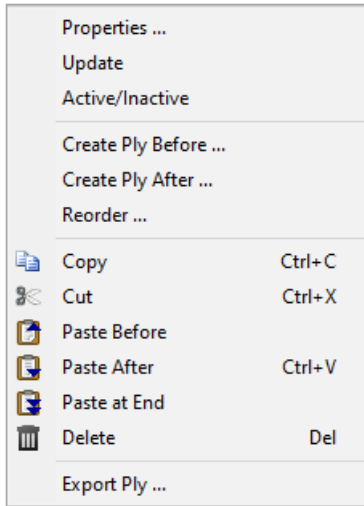
Figure 2.87: Right-Click Modeling Ply Menu

- **Properties:** Display the **Modeling Ply Properties** dialog.
- **Update:** Updates the selected Modeling Ply.
- **Active/Inactive:** Activate or deactivate the selected Modeling Ply. Inactive plies are defined in the database but not considered in the analysis.
- **Create Ply Before:** Create a new ply before the selected one.
- **Create Ply After:** Create a new ply after the selected one.
- **Reorder:** Move the selected Modeling Ply (or plies if several are selected) before or after another defined ply.

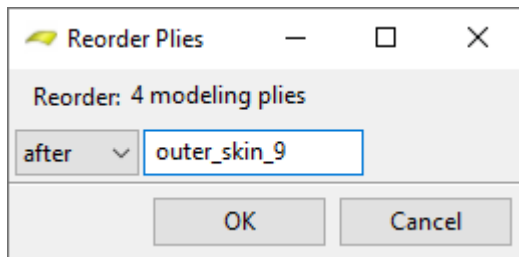

- **Copy:** Copy the selected Modeling Plies to the clipboard.
- **Paste at End:** Paste Modeling Plies from the clipboard to the end of the selected Modeling Group.
- **Paste Before:** Paste Modeling Plies from the clipboard before the selected ply.
- **Paste After:** Paste Modeling Plies from the clipboard after the selected ply.
- **Delete:** Delete the selected Modeling Plies.
- [Export Ply \(p. 158\)](#)

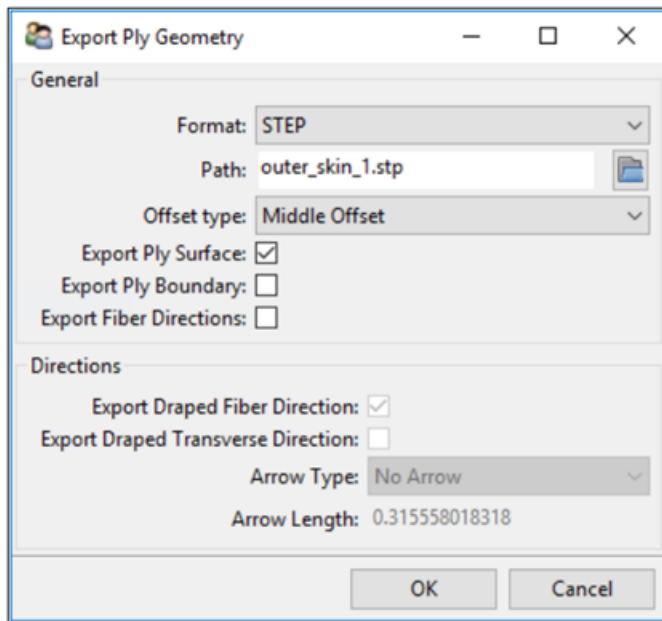

2.1.10.5. Interface Layer Properties

Introduction

A lay-up can also include an Interface Layer for carrying out a fracture analysis of a composite solid model in the Mechanical application. The interface layer is a separation layer in the stacking sequence. It can be used to analyze the growth of existing cracks. The crack topology is defined with an interface layer in ACP while all other fracture settings are specified in Engineering Data (material models) or Mechanical application.

Note:

Interface Layers are only taken into consideration in solid model generation and further processes. All shell-based analyses ignore any Interface Layers.

Mechanical APDL Solver

The interface layers are exported as [INTER204](#) or [INTER205](#) elements and can easily be used to set up a Cohesive Zone Model (CZM) or a Virtual Crack Closure Technique (VCCT) analysis. They can also be used to define contact zones between two layers. For more information, see [Interface Delamination and Contact Debonding](#) in the *Mechanical User's Guide*.

LS-DYNA Solver

Supported since Release 2025 R1.

Interface Layers are converted into zero volume LS-DYNAA cohesive elements (ELFORM=19) with a material model *MAT_COHESIVE_MIXED_MODE. In the **Engineering Data**, it is defined by material model **Bilinear for Interface Delamination**.

While contact debonding between plies is not supported yet, debonding between bodies is supported. The setup can be done directly in the Mechanical application (Interface Layer is not needed).

Bonded contacts are converted into LS-DYNA tiebreak contacts with a fracture model based on *MAT_COHESIVE_MIXED_MODE. In the **Engineering Data**, the supported cohesive zone material model is **Fracture-Energies based Debonding**.

For more information, see [LS-DYNA User's Guide](#).

LS-DYNA Solver Limitation: The Open Area feature of the ACP Interface Layers is not supported.

Definition

The Interface Layer is defined by two sets of surfaces:

- The first set is the total surface of the open interface. This is the surface along which a crack can propagate. It is defined by an Oriented Selection Set in **Interface Layer Properties** dialog under the **General** tab.

Figure 2.88: Interface Layer Properties - General

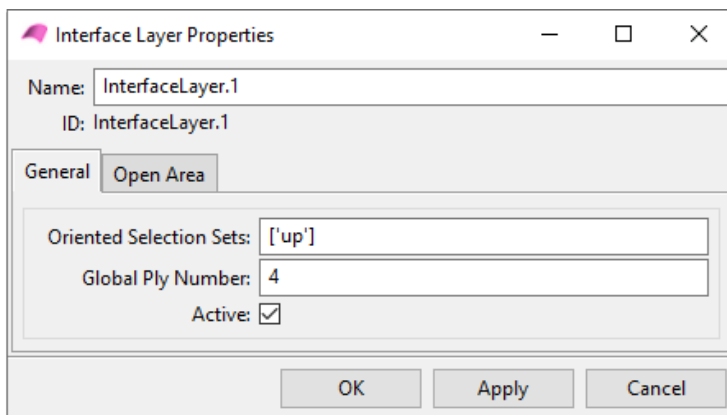

- The second set is the surface of the open interface. It is defined by an Oriented Selection Set in **Interface Layer Properties** dialog under the **Open Area** tab.

Figure 2.89: Interface Layer Properties - Open Area

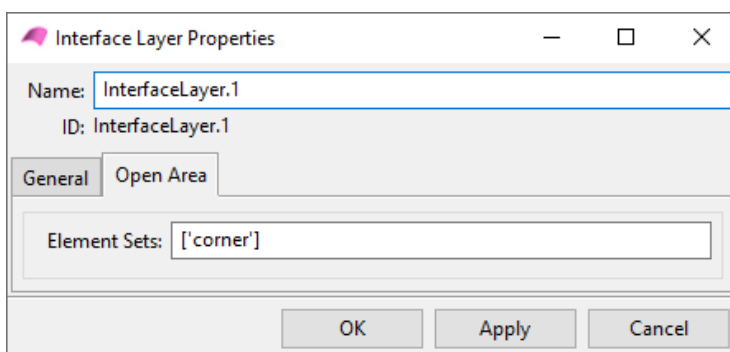

The Interface Layer can be activated or deactivated with a check box. You can also change the global number of an Interface Layer (**Global Ply Number**).

2.1.10.6. Butt Joint Sequence

The Butt Joint Sequence allows you to define butt joints between Modeling Plies. A butt joint consists of sequences (primary and secondary plies) which specify the lay-up on both sides of a butt joint. The Butt Joint Sequence object automatically detects where the selected plies join and generates butt joints instead of drop-offs.

Figure 2.90: Drop-Off Elements and a Butt Joint Between Two Cores

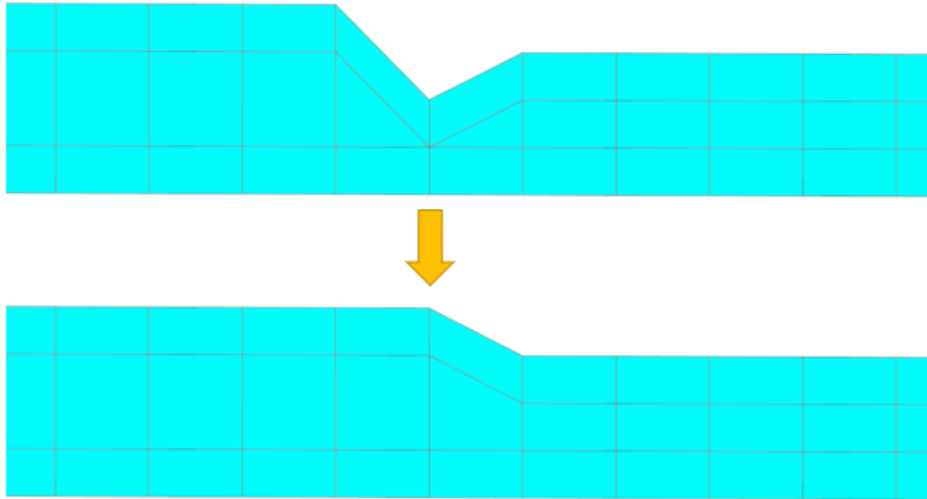

The **Butt Joint Sequence Properties** window contains the following options:

Butt Joint Sequence Properties
— □ ×

Name:

ID: ButtJointSequence

General

Active:

Global Ply Number:

Primary Plies

Sequence	Level
core	1
alu	2

Secondary Plies

Secondary Plies:

Currently only the Section Cut accounts for Butt Joint Sequences.

- **Active:** Active plies are considered in an analysis. Inactive plies are present but not considered.

- **Global Ply Number:** Defines the global ply order. By default, a new Sequence is added after the last one in the Modeling Group. The order of the Plies in the Modeling Groups is equal to this value.
- **Primary Plies:** Sequences which pass their thickness onto the other plies of a Butt Joint Sequence. A Primary Ply can be a Modeling Ply or a Modeling Group. The **Level** column specifies which sequence defines the thickness at a butt joint. The sequence with the lower level is dominant where the other sequence inherits the thickness. Potential differences in the thickness between the sequences are graduated over one element within the sequence with the higher level (the transition zone in the following image). No butt-joint is created between plies with equal level.

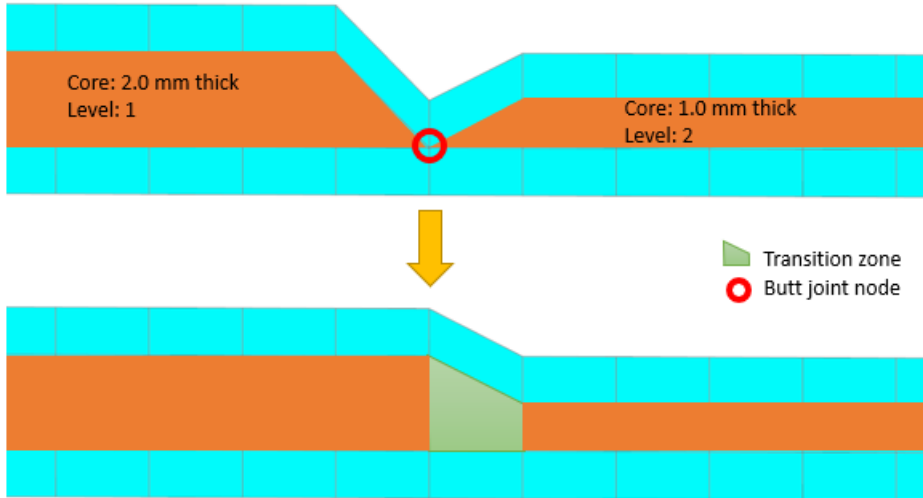

- **Secondary Plies:** Secondary plies inherit the thickness from Primary Plies, but do not pass it further. So, drop-offs are generated where two secondary plies join.

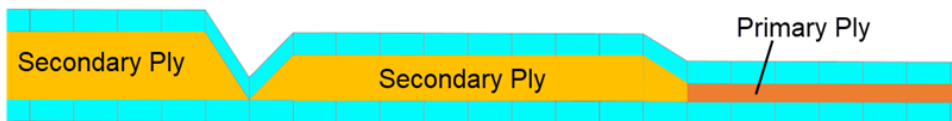

In most cases, you can define a Butt Joint Sequence without the use of secondary plies. An example where secondary plies may be necessary would be a butt joint on a cylinder where you need drop-offs:

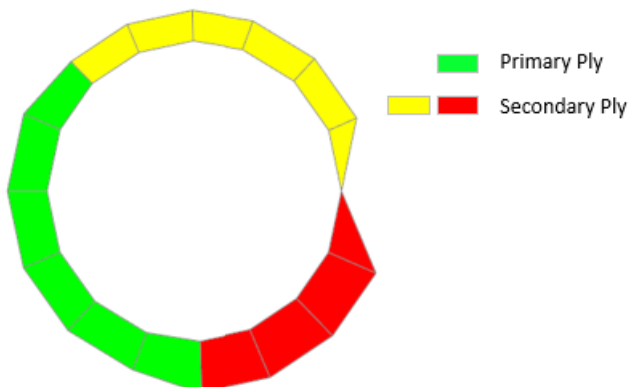

2.1.10.6.1. Butt Joint Sequence Notes and Limitations

The following is a list of notes limitations of the Butt Joint Sequence:

- A Modeling Ply can only be used in one Butt Joint Sequence
- Butt Joint Sequences do not affect shell models. They are only considered in [Section Cuts \(p. 170\)](#)
- [Solid model extrusion \(p. 183\)](#) does not consider butt joints
- A Butt Joint Sequence can only be linked to Modeling Plies with a lower Global Ply Number.
- The butt joint can not be updated if a ply sequenced between the first and last ply of the butt joint covers the node where the plies join, shown in the following diagram:



- [Modeling groups \(p. 139\)](#) may be easier to work with if a butt joint consists of a large number of plies

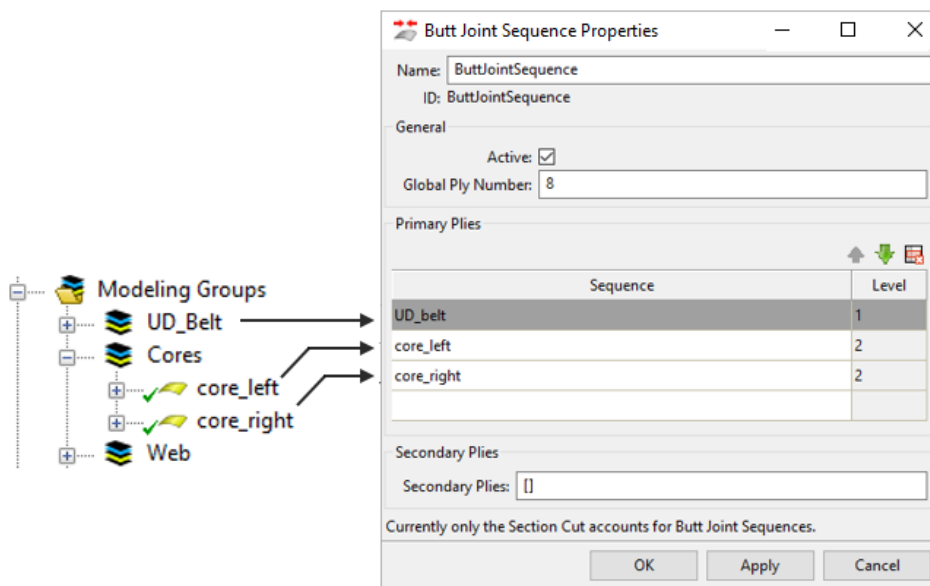

2.1.10.7. Reordering Modeling Plies, Interface Layers, and Butt Joint Sequences

Modeling Plies, Interface Layers and Butt Joint Sequences can be reordered using cut-and-paste (**Ctrl+X**, **Ctrl+V**) or drag-and-drop. This affects the Global Ply Number as follows:

- If you paste or drop objects onto another Modeling Ply, Interface Layer, or Butt Joint Sequence, they are inserted after the selected target. Global Ply Numbers after the target are automatically updated, so the list remains sequential. Conflicting Global Ply Numbers of other plies are also renumbered automatically.
- If the objects are pasted or dropped onto a Modeling Group, they retain their original Global Ply Number.

2.1.10.8. Production Ply

The context menu of the Production Ply has the following options:

Figure 2.91: Production Ply Context Menu

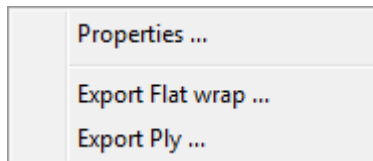

- **Properties:** Display the **Production Ply Properties** dialog. These properties cannot be edited, but can be viewed or printed for informational purposes.

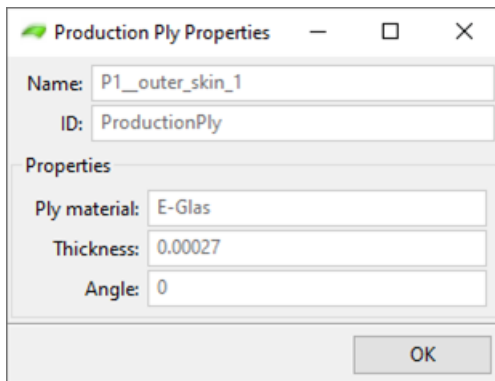

- **Export Flat Wrap:** Export the flat wrap as a .DXF, .IGES, or .STP file for production or design. The draping option must be activated to obtain a flat wrap. Refer to [Draping \(p. 279\)](#) for more information on draping and flat wrap.
- [Export Ply \(p. 158\)](#)

2.1.10.9. Analysis Ply

The context menu of the Analysis Ply has the following options:

Figure 2.92: Analysis Ply Context Menu

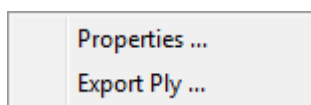

- **Properties:** Display the **Analysis Ply Properties** dialog. These properties cannot be edited, but can be viewed or printed for informational purposes.

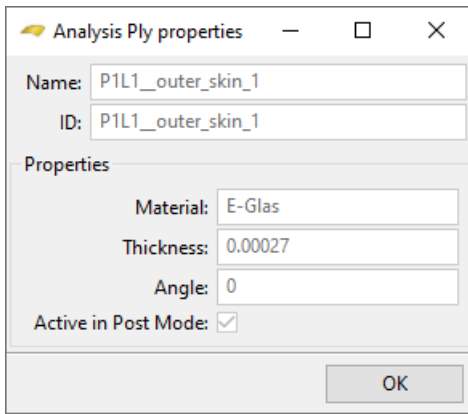

- [Export Ply \(p. 158\)](#)

2.1.10.10. Import from / Export to CSV File

The CSV interface allows you to create a comma separated value file to be edited in a spreadsheet program such as Excel or OpenOffice. This can be efficient if you wish to edit the parameters of many plies.

For additional information on the format, see [CSV Format \(p. 258\)](#).

2.1.10.10.1. Export

All the information are exported to a `.csv` file. This file can be used to give the lay-up information back to a CAD System or can be modified and imported.

2.1.10.10.2. Import

The modified `.csv` file can be imported. There are three different import options to handle the update of the lay-up:

- **Update Lay-up:** During the import operation, definitions are updated, additional plies are generated and deleted according to the `.csv` file.
- **Update Properties Only:** During the import operation, definitions are updated with properties given.
- **Recreate Lay-up:** During the import operation, existing lay-up is deleted and generated from scratch.

Figure 2.93: CSV Import with Update Options

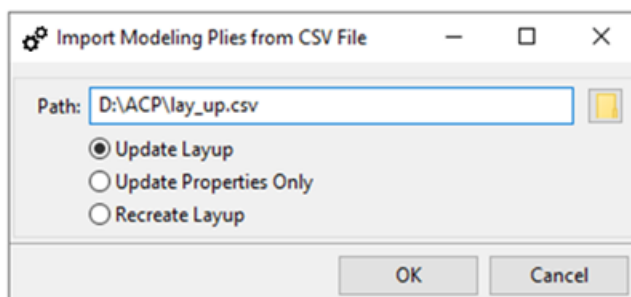

2.1.10.11. Export Ply Geometry

You can export the ply geometry and fiber directions to a CAD file format. Using this feature, you can check geometry clashes in CAD assemblies. Other uses may include using the data for CNC programming or for the projection of orientation vectors of the fibers onto tooling surfaces. It is possible to export the surfaces or boundaries with an offset. This gives you full control over surfaces to be exported.

The Export Ply Geometry feature has the following settings:

- **Format:** The geometry file format (STEP, IGES or STL). The STL format only supports the ply surfaces. Directions and boundaries can only be exported in the STEP or IGES format.
- **Path:** Specify the file name and file path.
- **Ply Level** (only available for Export Ply Geometry at Modeling Group level):
 - **Modeling Ply Wise:** Every Modeling Ply is exported.
 - **Production Ply Wise:** Every Production Ply is exported.
 - **Analysis Ply Wise:** Every Analysis Ply is exported.
- **Offset Type:**
 - **No Offset:** Ply geometry is exported with no offset to the reference surface (Oriented Selection Set).
 - **Bottom Offset:** Bottom surface of the ply relative to the direction of the reference surface is exported.
 - **Middle Offset:** Middle surface of the ply is exported. (default)
 - **Top Offset:** Top surface of the ply relative to the direction of the reference surface is exported.
- **Export Ply Surface:** Ply surface is exported as a shell surface.
- **Export Ply Contour:** Outlining contour of the ply surface is exported as perimeter lines.
- **Export Fiber Directions:** Fiber orientations are exported as orientation vectors.
 - **Export Draped Fiber Direction:** Include the draped fiber direction (the fiber direction is included if draping is not enabled).
 - **Export Draped Transverse Direction:** Include the draped transverse direction (the transverse direction is included if draping is not enabled).
 - **Arrow Type:** Choose between **No Arrow** (line without an arrowhead), **Standard Arrow** and **Half Arrow**.
 - **Arrow Length:** Specify the arrow length.

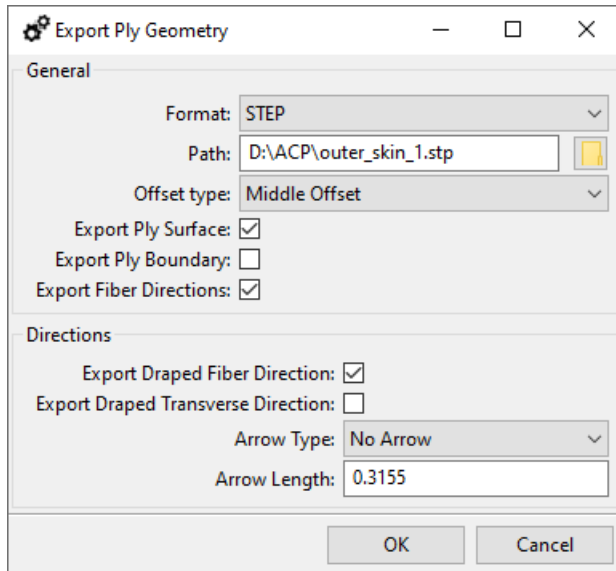
Figure 2.94: Export Ply Geometry Window

2.1.11. Imported Modeling Group

Imported Modeling Groups organize plies which are independent of the shell reference surface. Imported Modeling Groups and the attached Imported Plies do not contribute to the standard lay-up that is defined by the Modeling Plies applied to a shell reference surface. The table below, [Table 2.1: Key Differences Between a Modeling Ply and Imported Modeling Ply \(p. 160\)](#), lists the major differences when compared to a [Standard Modeling Ply \(p. 142\)](#).

The structure of the Imported Modeling Group follows the pattern of the standard Modeling Group and is described in the section above, [Modeling Group Structure \(p. 139\)](#). The equivalent to Modeling Ply, Production Ply and Analysis Ply are Imported Modeling Ply, Imported Production Ply and Imported Analysis Ply, respectively.

An example workflow is available in [Chapter 4: 3D Ply Workflow - Imported Plies \(p. 342\)](#).

2.1.11.1. Tree Object Context Menu

The context menu of the Imported Modeling Group contains the following options:

- **Properties:** Show the dialog window.
- **Update:** Update the model until all Imported Modeling Plies of this group are up to date.
- **Create Imported Ply:** Add a new Imported Modeling Ply.
- **Paste:** Create a new Imported Modeling Ply by copying the object on the clipboard.
- **Delete:** Remove all attached Imported Modeling Plies. Then remove the group object itself.

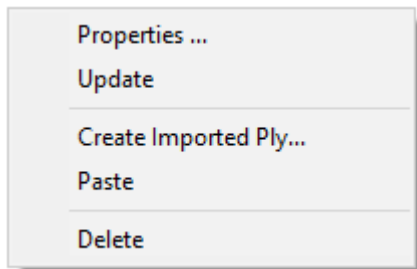

2.1.11.2. Imported Modeling Ply

An Imported Modeling Ply represents a single ply with a 3D surface mesh which is independent of the reference surface. This allows you to model thick and/or complex 3D laminates in ACP based on separate ply geometries. The Imported Modeling Ply can be used in combination with an Imported Solid Model (lay-up mapping). The section [3D Ply Workflow - Imported Plies \(p. 342\)](#) in chapter four provides a sample workflow and instructions on how to work with Imported Plies.

The table below lists the key differences between a standard Modeling Ply and an Imported Modeling Ply:

Table 2.1: Key Differences Between a Modeling Ply and Imported Modeling Ply

	Modeling Ply	Imported Modeling Ply
Mesh and Extension	Scoped to the shell reference surface	Holds its own imported mesh (surface) that is independent of the reference surface
Orientation	The lay-up orientation is defined by Oriented Selection Sets	The orientation is defined by the element normals of the imported mesh and the offset type (bottom, middle, or top)
Reference Direction	The reference directions of the ply are defined by Oriented Selection Sets	Supports the same features as an Oriented Selection Set, but the definition is part of the Imported Modeling Ply object
Material	Supports Fabrics, Stackups and Sub-Laminates	Supports Fabrics only
Shell Model / Analysis	Contributes to the shell lay-up	Is ignored in any shell analysis
Solid Model Extrusion	Considered in the standard Solid Model feature	The standard solid model extrusion ignores imported plies
Imported Solid Model / Lay-Up Mapping	Considered in the lay-up mapping of the Imported Solid Model if the scope is set to Element Sets	Considered in the lay-up mapping of the Imported Solid Model if the scope is set to Use Imported Plies

The context menu of an Imported Modeling Ply contains these actions:

- **Properties:** Display the ply properties dialog.
- **Update:** Update the model until this ply is up-to-date.

- **Active/Inactive:** Choose whether an Imported Ply is active or suppressed in all subsequent analyses.
- **Copy:** Copy into the clipboard.
- **Paste:** Create a new Imported Modeling Ply by copying the object in the clipboard.
- **Delete:** Delete the selected ply.

2.1.11.2.1. Imported Modeling Ply Properties

Standard features in ACP are used to define the thickness distribution, reference and fiber directions. An Imported Modeling Ply contains the properties listed below. Since the meaning is often identical if compared with an Oriented Selection Set or Modeling Ply, it is classified with the same wording.

General Properties

Refer to the figure below, **General Properties Options**.

- **Offset:** Determines if the surface mesh defines the bottom, mid or top surface of the ply.
- **Mesh Input:** Indicates whether the mesh was imported from a HDF5 Composite CAE or from a CAD geometry. This is automatically set by the application based on the input source and is therefore read-only.
- **CAD Surface:** If the Mesh Input is From Geometry, then the selected Virtual Geometry defines the surface of the ply.
- **Selection Method:** Defines the mapping algorithm for the Rosettes if more than one Rosette is used. For more information, see Reference Direction in the section above, [Oriented Selection Sets \(p. 132\)](#).
- **Rosettes:** Select which method one or more [Rosettes \(p. 103\)](#) will define the Reference Direction for each element.
- **Reference Direction Field:** Defines the direction column of a 3D Look-Up Table. Only applicable to the tabular values method.
- **Rotation Angle:** Angle (in degrees) to rotate the Reference Direction around the Orientation Direction. For more information, see [Use Cases for Rotation Angle \(p. 135\)](#).
- **Ply Material:** Select the Fabric that defines the material of the ply and nominal thickness.
- **Ply Angle:** Set the design angle between the reference direction and the ply fiber direction.

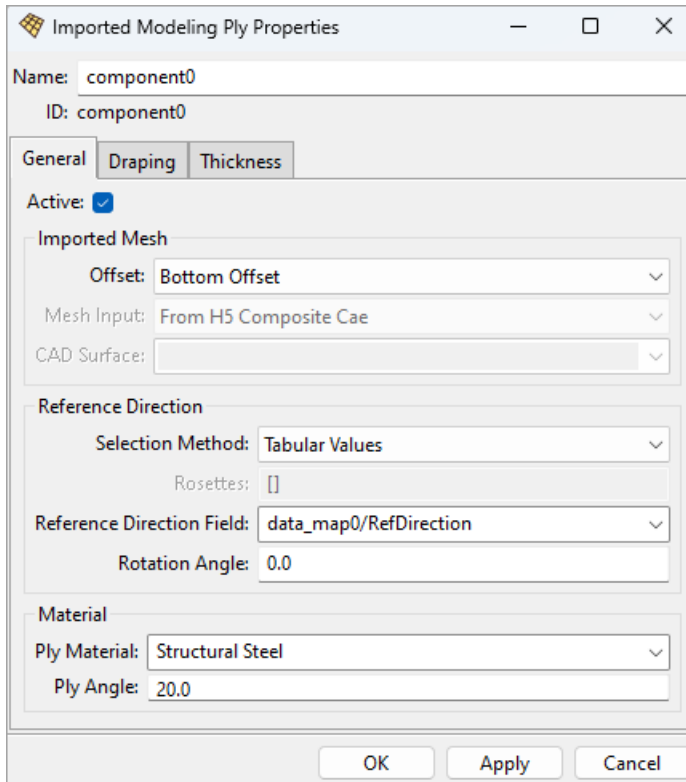
Figure 2.95: General Properties Options

Draping Properties

Refer to the figure below, **Draping Properties Options**.

- **Type:** Specifies the type of draping
 - **No draping:** Constant thickness defined by the Fabric
 - **Tabular values:** Variable thickness by mapping a LookUp Table field
- **Correction Angle 1:** Sets the draped fiber direction
- **Correction Angle 2:** Sets the draped transverse direction

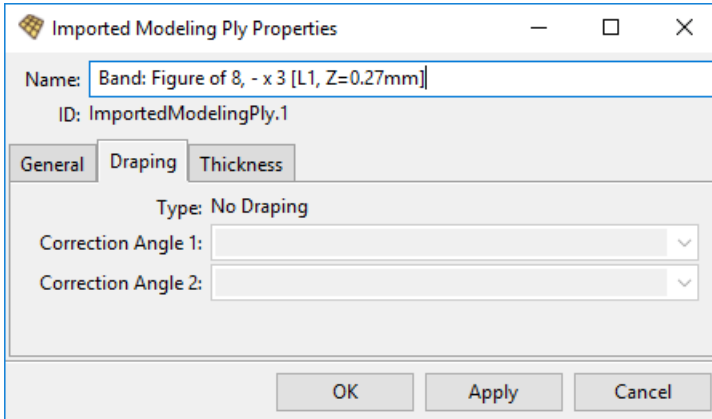
Figure 2.96: Draping Properties Options

Thickness Properties

Refer to the figure below, **Thickness Properties Options**.

- **Type:** Thickness definition method
 - **Nominal:** The thickness defined in Fabrics is used for the thickness definition.
 - **From Table:** A data field evaluates the thickness. ACP interpolates or extrapolates the thicknesses for each element.
- **Thickness Field:** Thickness is determined by mapping the selected LookUp Table Column to the mesh.
- **Thickness Field Type:**
 - **Absolute Values:** Values in the Look-Up Table define the thickness.
 - **Relative Scaling Values:** Values in the Look-Up Table are scaling factors.

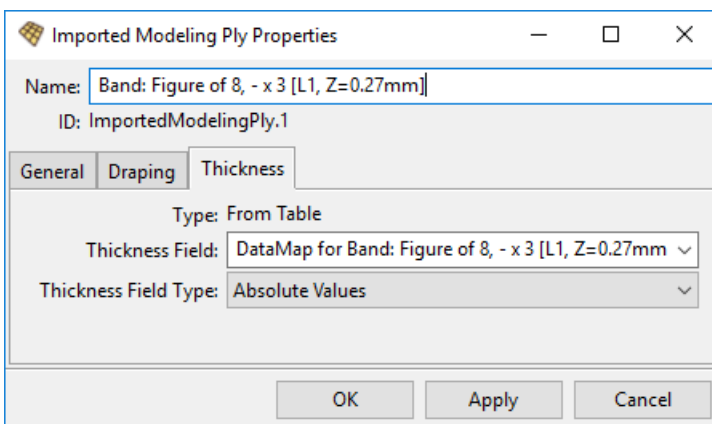
Figure 2.97: Thickness Properties Options

Limitations

- StackUps and Sublaminates are not supported as ply material.

- The ACP model always needs a reference surface, even if it is not relevant in the lay-up mapping (Imported Solid Model) workflow in combination with Imported Plies.
- The CAD geometry must be a surface. Solid geometries are not supported.
- **Export Composite Definitions to ACP File ...** does not support Imported Ply objects
- The Excel Interface cannot be used in combination with Imported Plies.
- The features **Sensor** and **Ply Book** do not take Imported Plies into account.
- The variable material workflow is not supported. That includes the field definitions and material plots.
- The **HDF5 Composite CAE Export** does not support Imported Plies.

2.1.11.3. Imported Production Ply

An Imported Production Ply is the output of an Imported Modeling Ply update. The context menu contains the following option:

Properties: Display the Imported Production Ply Properties dialog. These properties cannot be edited but can be viewed or printed for informational purposes.

Figure 2.98: Imported Production Ply Dialog

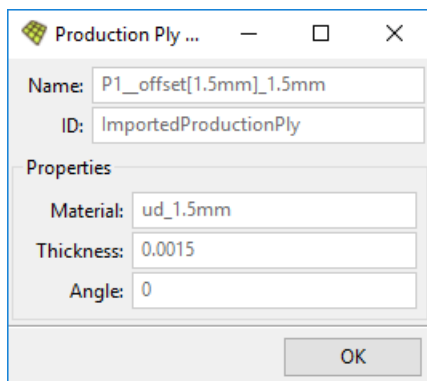

2.1.11.4. Imported Analysis Ply

An Imported Analysis Ply is the result of an Imported Modeling Ply update. The context menu contains the following option:

Properties: Display the Imported Analysis Ply Properties dialog. These properties cannot be edited, but can be viewed or printed for informational purposes.

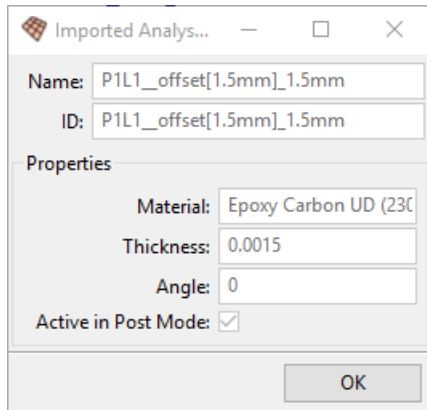
Figure 2.99: Imported Analysis Ply

2.1.12. Field Definitions

During the [Variable Material Data \(p. 303\)](#) workflow, you can define the variation of the scalar variables controlling the local state of the material properties over the finite element model using Field Definition objects. You can scope Field Definition objects to Element Sets, Oriented Selection Sets, and Modeling Plies.

If your field definition is based on Elements Sets or Oriented Selection Sets, all of the layers within your scoping are affected. When scoping to Modeling Plies, only the associated Analysis Plies are affected. Therefore, it is possible implement both a “layer-wise” as well as a “element-wise” application of field definitions in your finite element model. Parts of the finite element model not covered by Field Definition Objects assume default values of the field variables.

In order to understand the effect of a Field Definition Object, contour plots of the field variables are available [Field Definition Plot \(p. 231\)](#) topic of the [Lay-Up Plots \(p. 222\)](#) section.

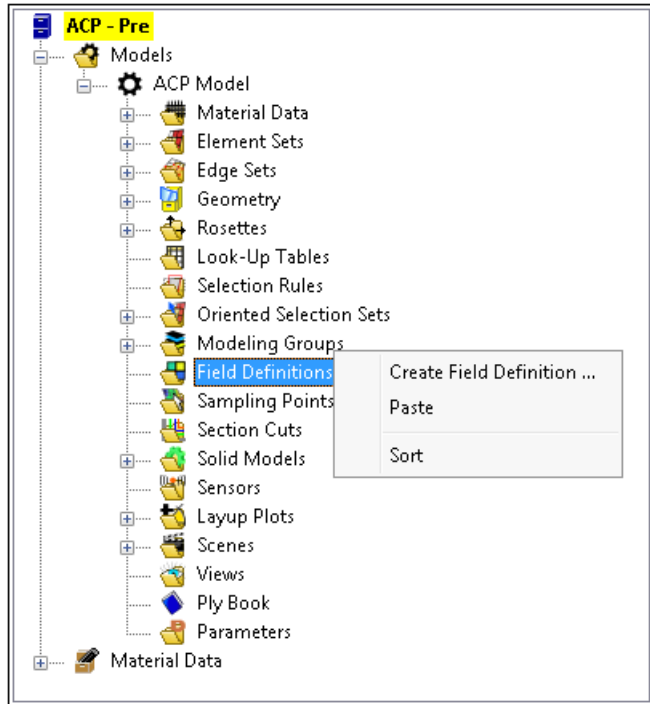
Figure 2.100: Field Definitions Context Menu

As illustrated below, once you create a **Field Definition** object, you use the context menu to define its features. Menu options include:

- **Properties:** Display the properties window of the selected Field Definition.
- **Update:** Update the selected Field Definition.
- **Active/Inactive:** Toggle field definition object active or inactive
- **Copy:** Copy the selected Field Definition to the clipboard.
- **Paste:** Paste a table Field Definition from the clipboard.
- **Delete:** Delete the selected Field Definition.

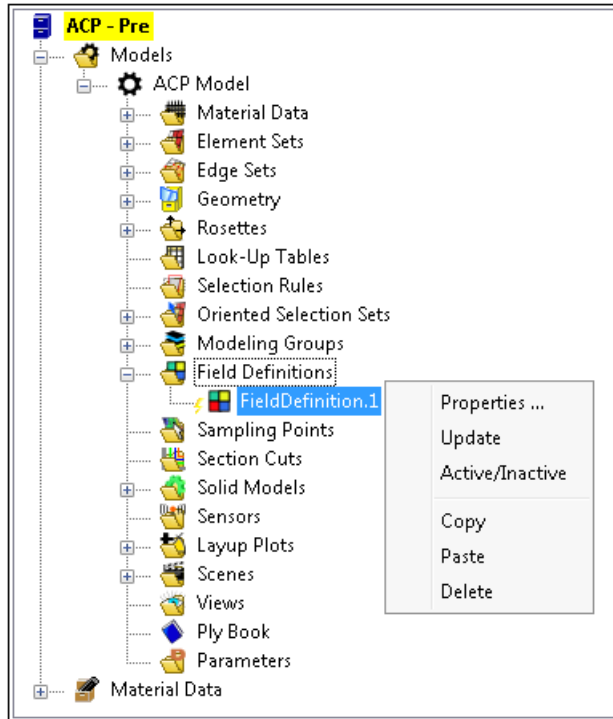
Figure 2.101: Field Definition Context Menu

Field Definition Object Properties

Field Definition objects can be used for element-wise and layer-wise specification of the variation of a scalar variable controlling Variable Material Data on subparts of your finite element model. You can scope layer-wise specifications to specific Modeling Plies. The properties dialog is illustrated below. Properties include:

- **Name:** Name of the Field Definition. This field is initially populated with a default name.
- **Active:** This selection indicates that the application processes the Field Definitions during your analysis. Inactive definitions are ignored.
- **Field Variable Name:** This drop-down menu provides a list of available [Field Variables](#) as defined in the Engineering Data Workspace. Note that the Temperature and Shear Angle field variables are not available for Field Definitions. Temperature is defined externally to ACP, and the Shear Angle is defined via draping calculations.
- **Scope Entities:** Entry field to define the applicable element-wise field definitions. You can use a combination of Element Sets and Oriented Selection Sets in order to scope the definition to subparts of your model. For layer-wise field definitions, you can use a combination of Modeling Plies to scope the definition to subparts of your model; the Field Definition will only be applied to Analysis Plies attached to the Modeling Plies.
- **Look-Up Table Column:** Select the scalar Look-Up Table column from which the state of the field variable is interpolated from.
- **Include Shell Offset:** Specify whether or not to include the shell offset of each analysis ply for the interpolation process. The default is to interpolate the state of the field variables at the

shell element centroid. For solid elements, the actual position of each analysis ply is automatically considered and this behavior cannot be changed.

Figure 2.102: Field Definition Object Properties

Element-Wise Field Definition

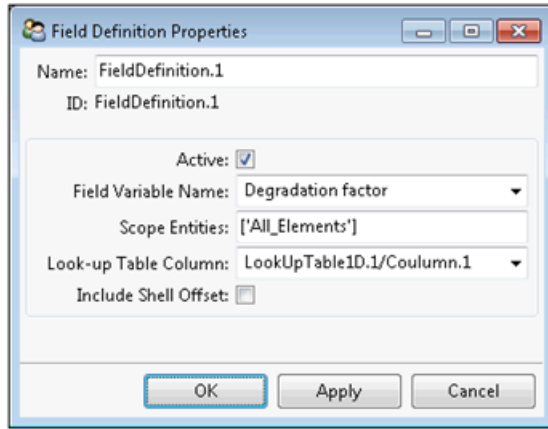

Layer-Wise Field Definition

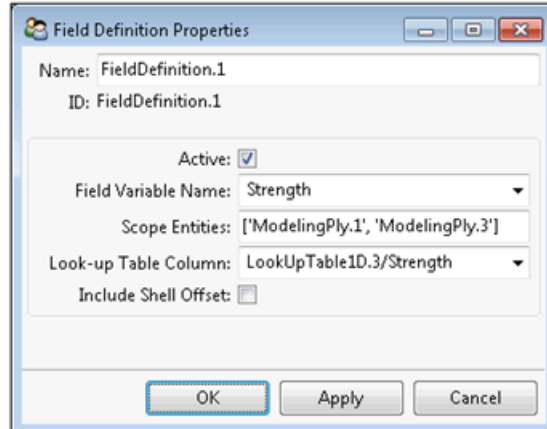

2.1.13. Sampling Points

The Sampling Point functionality provides lay-up, through-the-thickness, and laminate elastic property information.

ACP samples through the element near the given coordinates. After the update, all plies (Modeling Ply, Production Ply, and Analysis Ply) are listed for review. In the **General** tab of the **Sampling Point Properties** dialog the sampling point and direction can be defined.

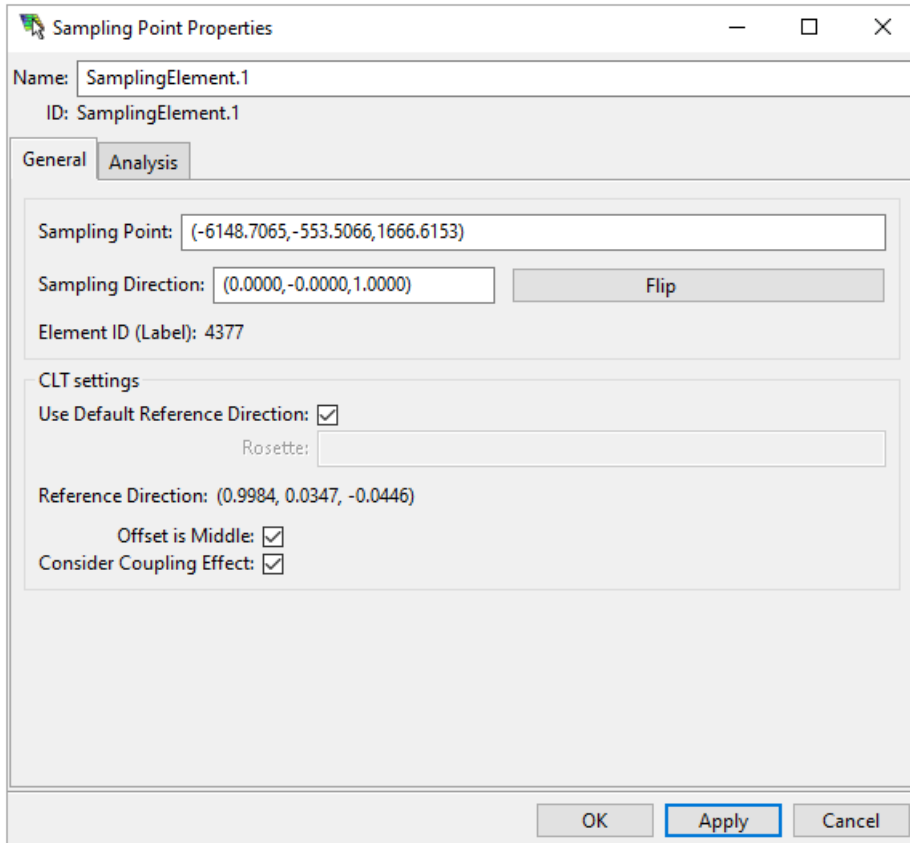
Figure 2.103: Sampling Point Properties (General Tab)

- **Sampling Point:** The sampling point in global coordinates. The nearest element to the point is the sample.
- **Sampling Direction:** Normal direction of the sampling point. The ply sequence will be given in this direction.
- **Element ID (Label):** Element number closest to the defined sampling point. (informational only)

A detailed description of the options **Offset is Middle** and **Consider Coupling Effect** can be found in [Analysis Options in the Composites Theory Reference](#). Use the arrow buttons to navigate easily through the ply definition.

The **Analysis** tab of the **Sampling Point Properties** dialog provides extended laminate analysis functionality. The lay-up can be visualized and analyzed by evaluating the polar properties, equivalent laminate stiffness matrices, and resulting engineering constants based on the classical laminate theory.

The lay-up visualization can be set to display Modeling, Production, and Analysis Plies present in the Sampling Point. The Material, Thickness, and Angle can be displayed additionally as text labels for every ply in the plot. The angle displayed for Modeling and Production Plies always matches the design angle in the Modeling Ply and Material definitions. Note that the angle for the Analysis Ply is always given in relation to the reference direction of the Sampling Point. This reference direction is

indicated by a yellow arrow at the Sampling Point in the Scene. Meanwhile, the sampling direction is indicated by the purple arrow, which you can change in the General tab if desired.

Note:

Classical Laminate Theory is described in [Composites Theory Reference](#).

Figure 2.104: Sampling Point Properties (Analysis Tab Containing Lay-up Sequence and Polar Properties)

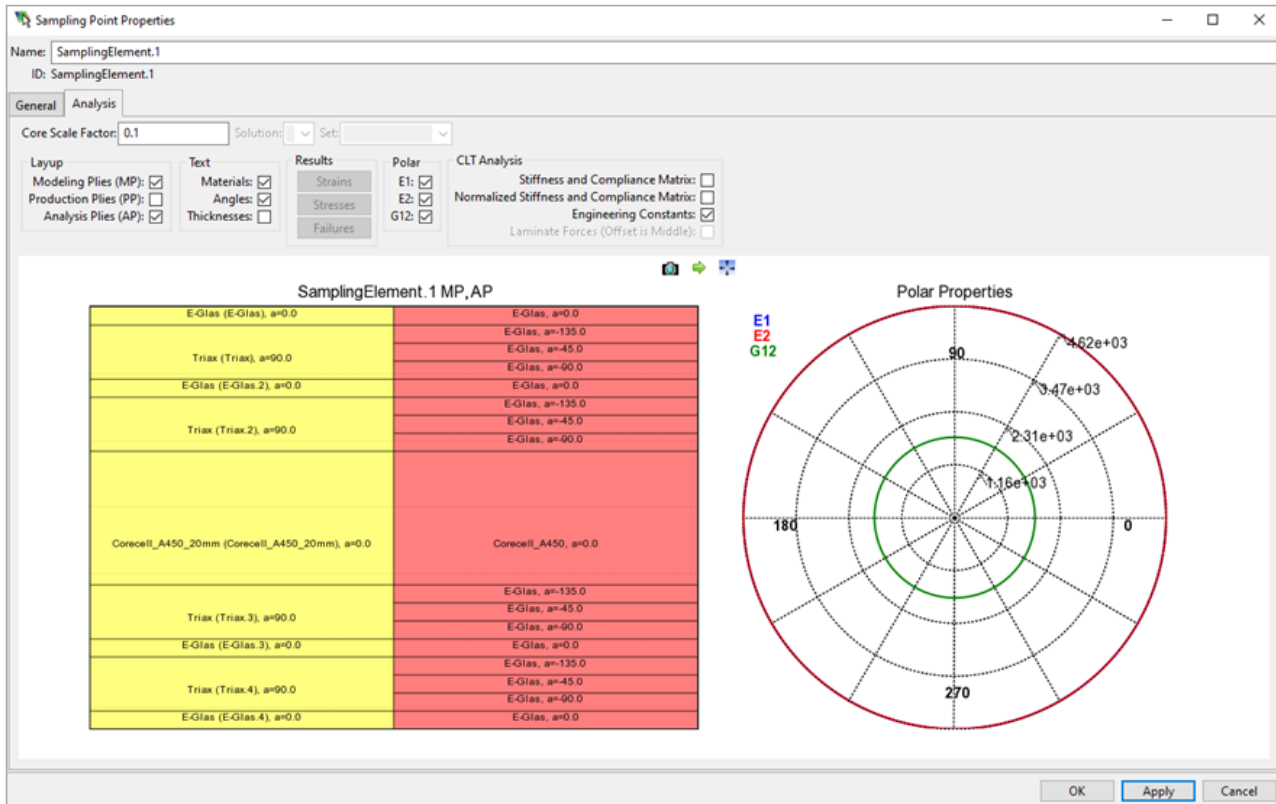

2.1.14. Section Cuts

Section Cuts enable a visual verification of the lay-up definition on an arbitrary section plane through the model. The lay-up definition at the Section Cut can be exported to Mechanical APDL or [BE-CAS](#) (p. 260).

The **Section Cut Properties** dialog contains the following options:

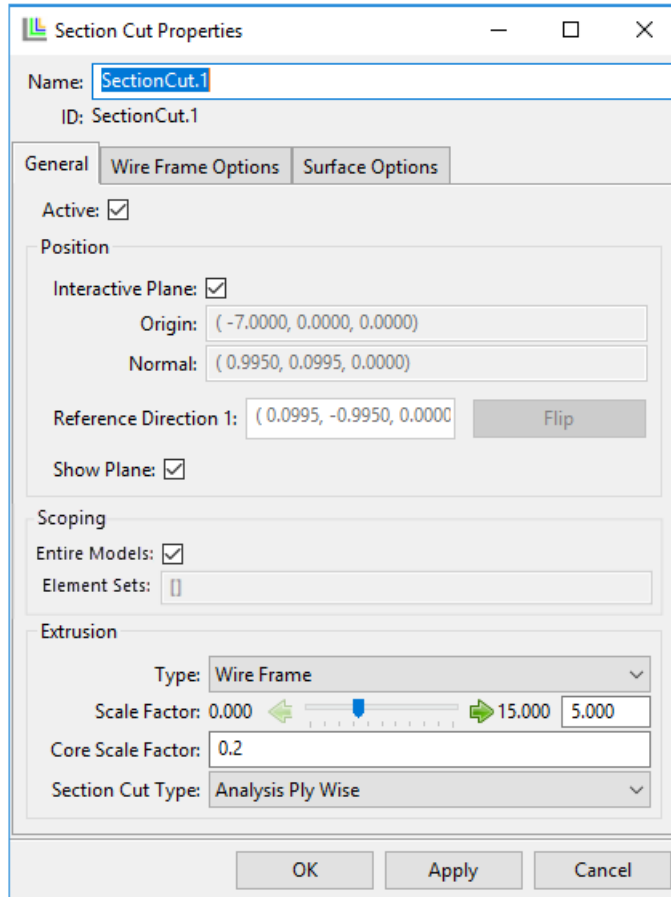
Figure 2.105: General Section Cut Properties

- **Name:** Name of the Section Cut.
- **Active:** Set to false to suppress the computation of the Section Cut.
- **Interactive Plane:** If active, modify the section plane directly in the Scene. If inactive, the following options are required:
 - **Origin:** Origin of the section plane.
 - **Normal:** Normal direction of the section plane.
 - **Reference Direction 1:** First in-plane reference direction (in-plane transverse direction). The normal and this direction define the coordinate system of the section cut. It is used to compute the section cut measures and to export the surface section cut.
- **Show Plane:** Plot the section plane.
- **Entire Model:** If active, the Section Cut applies to all shell elements in the model. Otherwise, only the selected Element Sets are considered.
- **Element Sets:** List of Element Sets to which the Section Cut is scoped.
- **Type:** [Mode of extrusion \(p. 173\)](#).
- **Scale Factor:** Scale the offsets of all plies.

- **Core Scale Factor:** Thickness of the core plies are scaled by this factor.
- **Section Cut Type:** Select which ply type is plotted:
 - **Modeling Ply Wise:** Modeling Plies are plotted.
 - **Production Ply Wise:** Production Plies are plotted.
 - **Analysis Ply Wise:** Analysis plies are plotted.

Figure 2.106: Wire Frame Options

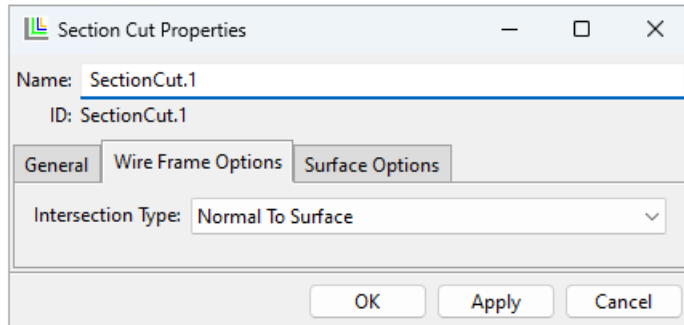

- **Interaction Type:** Define the intersection of the section plane and the model:
 - **Normal to Surface:** Plies are plotted as normal to the intersected elements.
 - **In Plane:** Plies are plotted in the section plane.

Figure 2.107: Surface Options

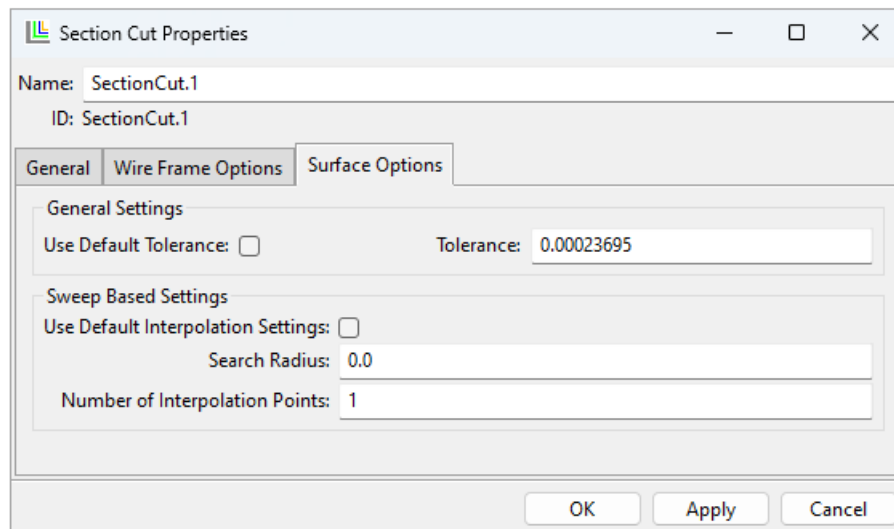

- **Use Default Tolerance:** Use the default tolerance (0.1% of the average element size). If unselected, you should specify the **Tolerance**:
 - **Tolerance:** Defines the minimum length of the line segments in a Section Cut. Segments shorter than the tolerance are merged. Small segments can occur if a Section Cut crosses an element corner as shown below. In some cases, the Section Cut can be relocated to avoid small segments.

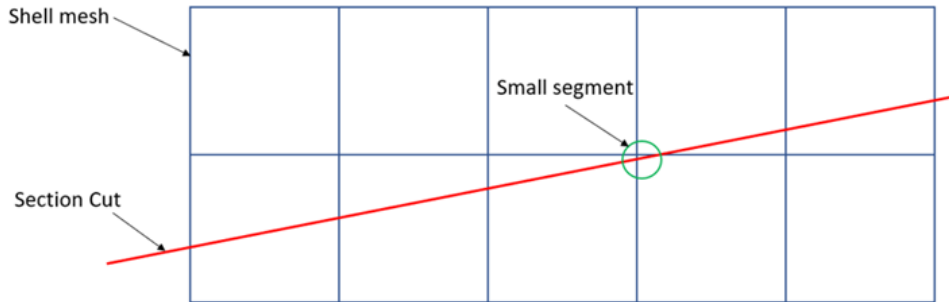
Figure 2.108: Section Cut Crossing an Element Corner

Sweep based extrusion:

- **Use Default Interpolation Settings:** Use default interpolation settings. If unselected, you must specify **Search Radius** and **Number of Interpolation Points**. For more information, see [3D Look-Up Table \(p. 112\)](#).

2.1.14.1. Types of Extrusion

The following extrusion types are available:

- **Wire Frame:** This type can be used to investigate the lay-up of shell elements. The mid-surface of the plies are represented by lines, as shown below.

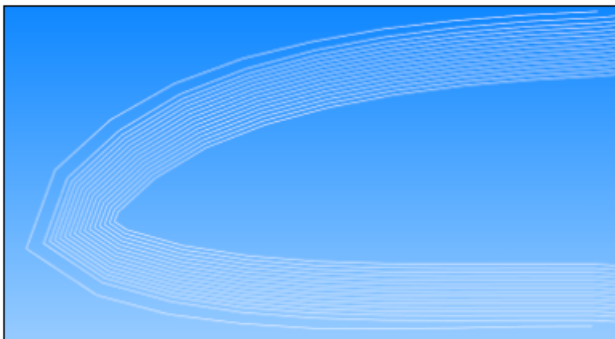

- **Surface Section Cut:** For this type, the plies are shown as surface elements. A surface Section Cut generates a continuous mesh w can be used for 2D analyses. Therefore, Drop-Off elements are generated by default at the ply boundaries (like the solid model extrusion). If this does not represent the real structural behavior, then you can use the [Butt Joint Sequence \(p. 153\)](#) to control the connectivity of the adjacent plies and Drop-Off behavior. The surface Section Cut supports two types of extrusion:
 - **Surface Normal:** The extrusion follows the element normals of the reference surface. The offset direction does not change during the extrusion.
 - **Surface Sweep Based:** The offset direction follows the interpolated element normals (potential field defined by the shell normals). The interpolation is based on a [Look-Up Table \(p. 107\)](#) that specifies the Search Radius and Number of Interpolation Points.

In general, the sweep-based algorithm is more robust in sharp corners with thick laminates; however, the extrusion of t-joints may be less accurate. The sharp corner in Figure 2.99 illustrates the difference between the extrusion algorithms.

- **Surface Normal:** The plies are illustrated by surface elements. The extrusion follows the element normals.
- **Surface Sweep Based:** The plies are shown as surface elements. The offset direction follows the interpolated element normals (potential field defined by the shell normals).

Figure 2.109: Element Normals

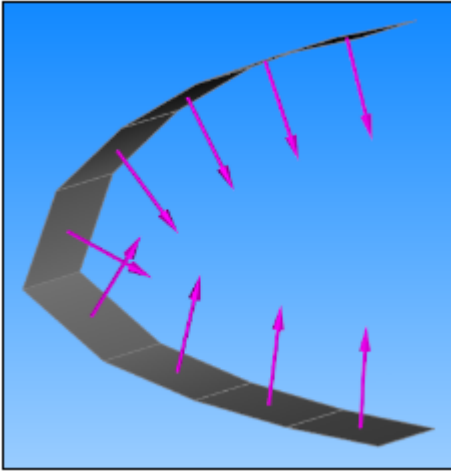

The interpolation is based on a [Look-Up Table](#) (p. 112) which specifies the **Search Radius** and **Number of Interpolation Points**.

Figure 2.110: Surface Normal vs. Surface Sweep Based Extrusion

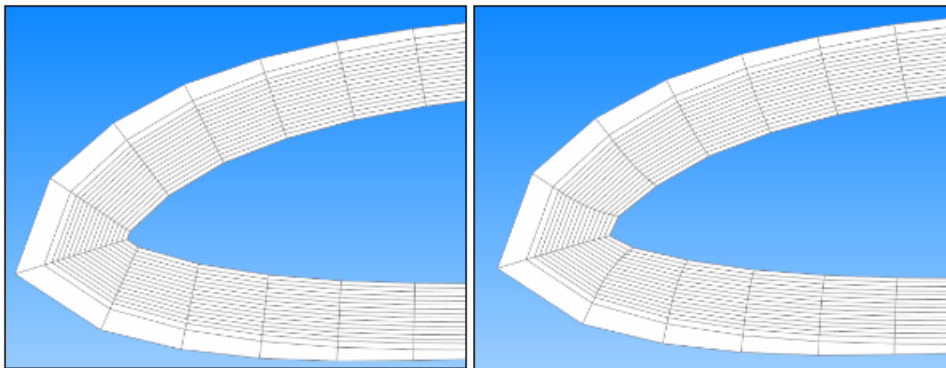

Section Cuts can also be used to plot ply-wise properties such as [angles](#) (p. 222). For more information, see [Lay-Up Plots](#) (p. 222).

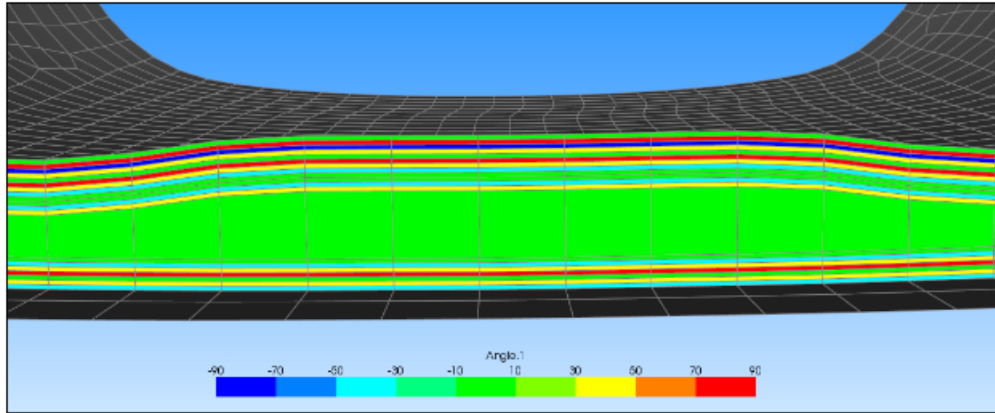
Figure 2.111: Ply-Wise Angles on the Surface Section Cut

2.1.14.2. Section Cut Notes

- The line segments are locally enlarged (if necessary) to improve the quality of the surface elements.
- Plies covering more than 3 components cannot be extruded (see figure below):

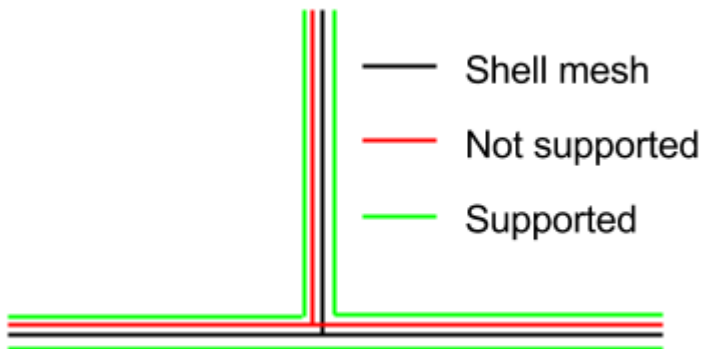
Figure 2.112: Supported Lay-up for T-Joints

2.1.14.3. Section Cut Export

The Section Cut can be exported in two formats:

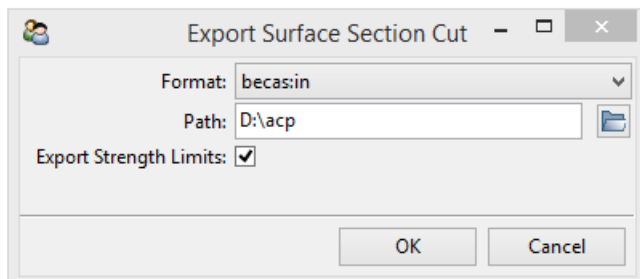
Figure 2.113: Export Surface Section Cut Options

- The **becas.in** format includes the 2D mesh, material properties, and element orientations.
- The **mapdl.cdb** format supports only the 2D mesh and the named selections (top and bottom node sets derived from the Element Sets of the shell mesh). This can be useful to fill the Section Cut with a core material (for example).

2.1.14.4. Computation of Equivalent Sectional Properties

The section cut feature implements the computation of the equivalent sectional properties. You can use sectional properties to model slender structures, such as wind turbine blades or helicopter blades, with beam elements. This significantly improves the efficiency of analyses, especially non-linear or transient analyses. The computed values can be used in combination with the preintegrated composite beam section of Mechanical APDL (see [Using Preintegrated Composite Beam Sections in the Structural Analysis Guide](#)) and element types **BEAM188** and **BEAM189**.

The computation can be run either by the Python shell of ACP or context menu of the Section Cut. Select the **Compute Equivalent Beam Properties...** item to open the analysis dialog.

Figure 2.114: Elastic Properties after Running Analysis of the Sectional Properties (via Run Analysis Button)

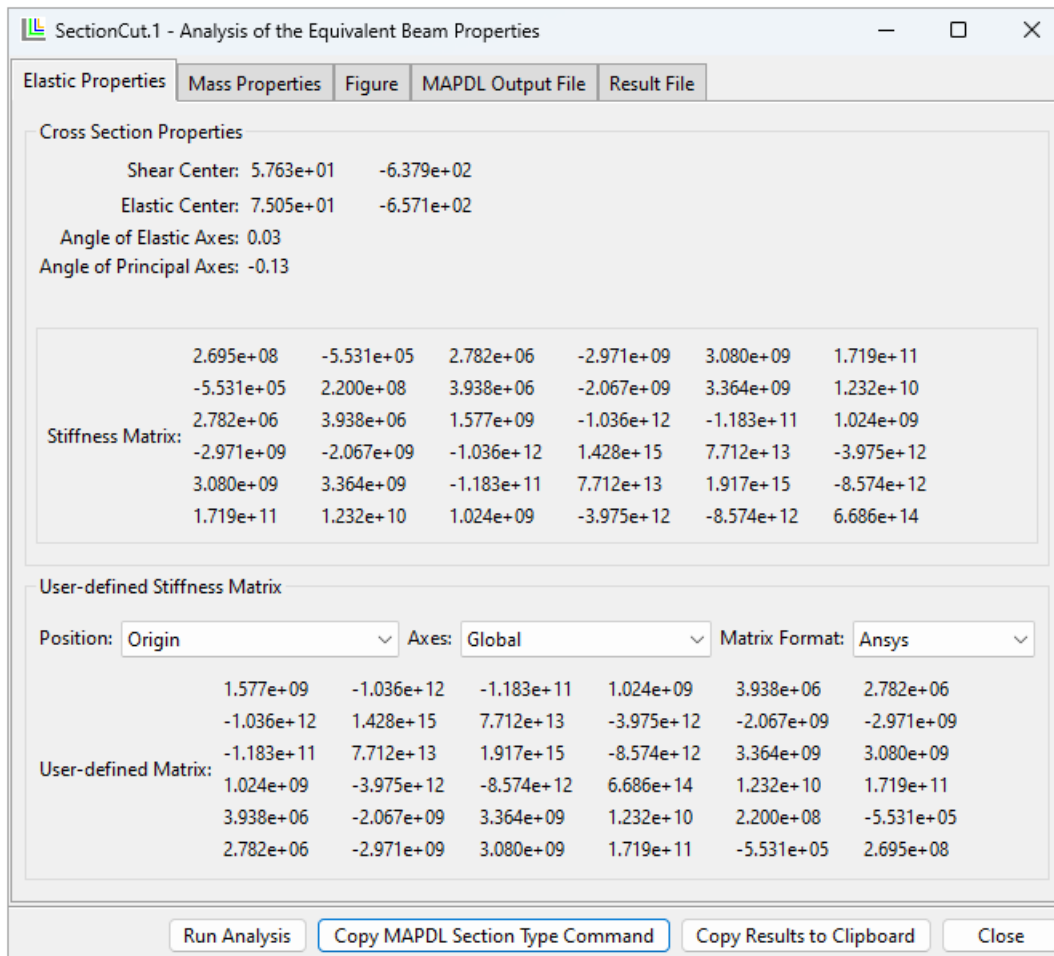

The dialog contains the following buttons:

- **Run Analysis:** Generate the input file for the Mechanical APDL solution, run the analysis, parse the results, and update the figure.
- **Copy Mechanical APDL Section Type:** Convert the stiffness and mass matrix into the Mechanical APDL **SECTYPE** command for a preintegrated composite beam and copy it to the clipboard. The command (string) can be used in Mechanical APDL or Mechanical via a command snippet to define the properties of beam elements.
- **Copy Results to Clipboard:** Copy all elastic and mass properties to the clipboard.
- **Close:** Close the dialog. Note that the results are not saved.

The sectional properties are computed with respect to the section cut's coordinate system that is defined by the origin, normal, and first reference direction of the section cut. The results are shown at the top of the **Elastic Properties** and **Mass Properties** tabs.

Both tabs have a user-defined section to convert the matrix with respect to the **Position** and **Axes** system. You can use the **Matrix Format** to order the entries of the matrices for the corresponding application. The computed matrices can be used in combination with the preintegrated composite beam section of Mechanical APDL (see [Using Preintegrated Composite Beam Sections in the Structural Analysis Guide](#)), if the Format is set to **Ansys**. For more information about the format of the stiffness and material matrix, see the [Theory \(p. 178\)](#) section.

The **Figure** tab shows the section cut mesh and the positions of the shear center, CoG, and elastic center with respect to the section cut's origin.

Figure 2.115: Section Cut Mesh and Results

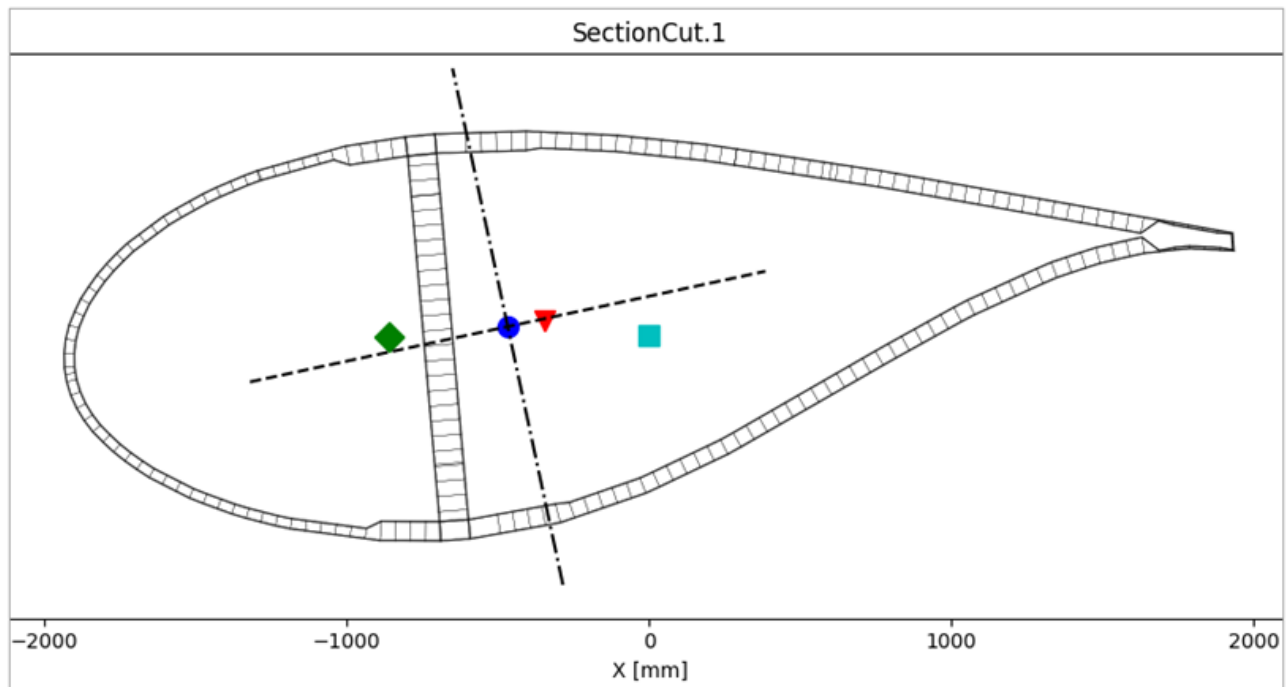

In case of errors, use the **Mechanical APDL Output File** and **Result File** to investigate the analysis.

2.1.14.4.1. Theory

The computation is based on the theories of [Giovotto et al. (1983)] (p. 369) and [Ghiringhelli et al. (1994)] (p. 369).

A 3D mesh slice (SOLID186 element) of the beam section is generated using section cuts, as represented in the figure below. The computational model of the section cut is automatically converted to the reference coordinate system, where x and y are the beam section in-plane axes, while the beam longitudinal axis follows the global z (positive).

Figure 2.116: 3D Representation of a Beam Slice (with Respect to the Global Coordinate System)

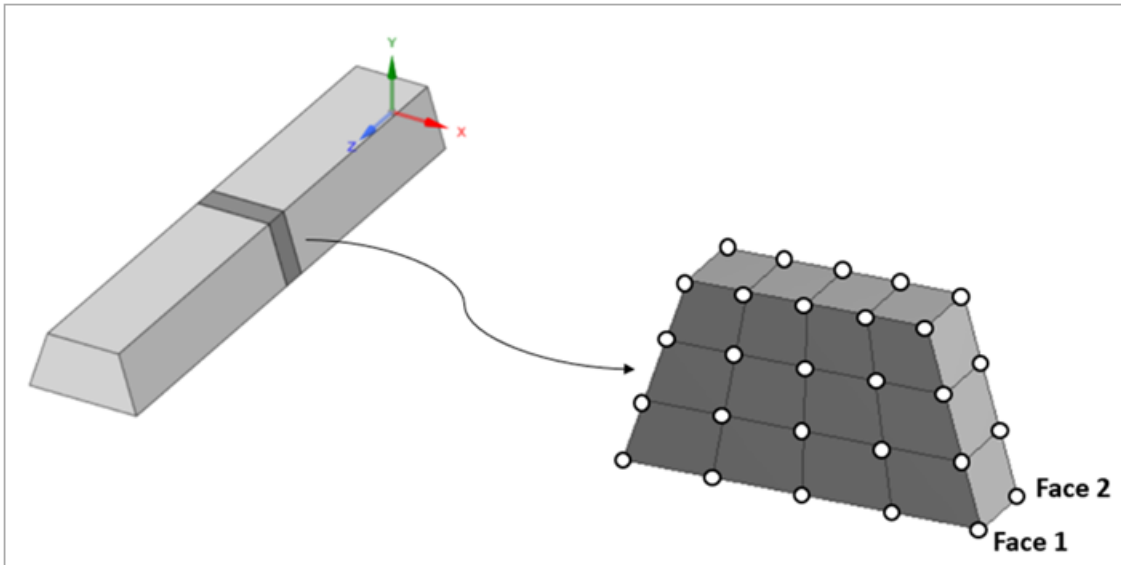

The global FE stiffness and mass matrix of the slice are then computed using the Mechanical APDL Solver.

The global mass matrix is used to compute the equivalent beam mass matrix per unit length.

The global stiffness matrix K^{fem} is used as the starting point to compute all the matrices required by the theory explained in [Giovotto et al. (1983)] (p. 369).

$$[K^{fem}] \{u\} = \{F\}$$

The global stiffness matrix is split into four submatrices (the subscripts 1 and 2 refer to face-1 and face-2 of the solid slice):

$$\begin{bmatrix} K_{11}^{fem} & K_{12}^{fem} \\ K_{21}^{fem} & K_{22}^{fem} \end{bmatrix} \begin{Bmatrix} u_1 \\ u_2 \end{Bmatrix} = \begin{Bmatrix} F_1 \\ F_2 \end{Bmatrix}$$

These four K-sub-matrices are then combined following the implementation explained in [Ghiringhelli et al. (1994)] (p. 369) to build the system of equations of [Giovotto et al. (1983)] (p. 369), solve them, and finally compute the stiffness matrix of the beam section.

2.1.14.4.2. Results

The results of the computation are the stiffness matrix of the cross section, mass matrix, and other section properties such as shear center and center of gravity. The primary results are with respect to the origin of the section cut and the global coordinate system of the section cut which is defined by the normal and reference direction 1.

The standard output stiffness matrix produced by this feature has the following form:

$$\begin{bmatrix} T_x \\ T_y \\ T_z \\ M_x \\ M_y \\ M_z \end{bmatrix} = \begin{bmatrix} K_{11} & K_{12} & K_{13} & K_{14} & K_{15} & K_{16} \\ & K_{22} & K_{23} & K_{24} & K_{25} & K_{26} \\ & & K_{33} & K_{34} & K_{35} & K_{36} \\ & & & K_{44} & K_{45} & K_{46} \\ & Sym & & & K_{55} & K_{56} \\ & & & & & K_{66} \end{bmatrix} \begin{bmatrix} \gamma_x \\ \gamma_y \\ \epsilon_z \\ \kappa_x \\ \kappa_y \\ \chi_z \end{bmatrix}$$

where,

- T_x and T_y are the shear forces along the x and y directions
- T_z is the force along the beam longitudinal axis (axial force)
- M_x and M_y are the bending moments around the x and y axes
- M_z is the torsional moment around the beam axis
- γ_x and γ_y are the transverse shear strains
- ϵ_z is the axial strain
- κ_x and κ_y are the curvatures in the x and y axes
- χ_z is the twist

All the K_{ij} represent a stiffness value. The ones on the main diagonal are:

Shear stiffness in x plane	$K_{11}=GA_x$
Shear stiffness in y plane	$K_{22}=GA_y$
Axial stiffness	$K_{33}=EA$
Bending stiffness in x plane	$K_{44}=EI_x$
Bending stiffness in y plane	$K_{55}=EI_y$
Torsional stiffness	$K_{66}=GJ$

This feature also computes the following important quantities:

- Elastic center coordinates

- Shear center coordinates
- Center of gravity coordinates
- Angle of the elastic axes
- Angle of the barycentric principal axes

The results of the computation are the stiffness matrix of the cross section, mass matrix, and other section properties such as shear center and center of gravity.

2.1.14.4.3. Best Practices

You can request for the stiffness and mass matrix to be printed out and reordered to follow the specific Ansys beam section type form **SECTYPE,,COMB,MATRIX**, which can be used to assign the computed equivalent beam properties to an Ansys beam element (such as **BEAM188** or **BEAM189**). See the `get_transformed_sectional_properties_matrix()` function of the Section Cut. There is an example at the end of this section which generates an input file for Mechanical APDL.

The `get_sectional_stiffness_behavior()` extracts the equivalent stiffness values from the matrix.

Reordering Example

The value K_{33} in the standard output becomes the value in position (1,1) of the **SECTYPE,,COMB,MATRIX**, while the value K_{55} becomes the value in position (3,3).

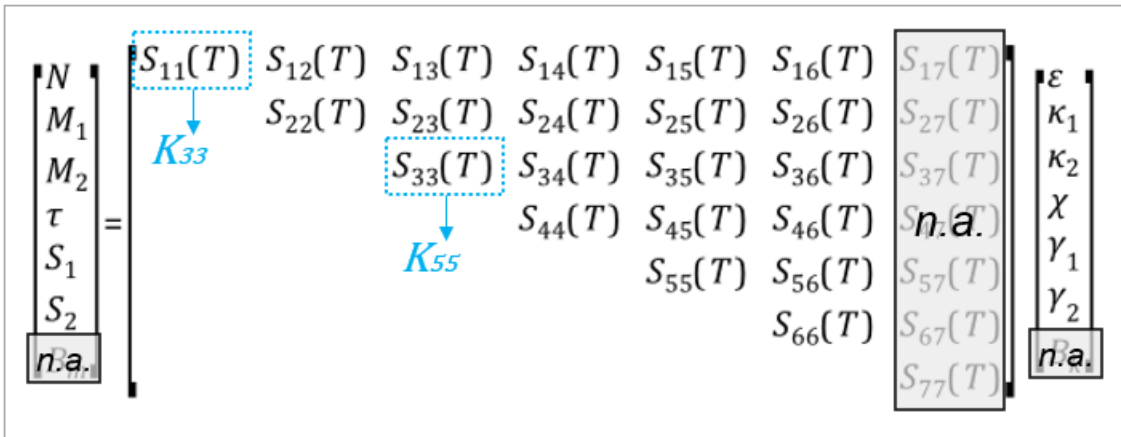

For a detailed description of the stiffness and mass matrix form in this case, see [Using Preintegrated Composite Beam Sections in the Structural Analysis Guide](#).

The position and orientation of the section cut are important. Typically, the section cut plane is perpendicular to the mesh and the origin is placed in the center of the mesh. The section cut provides methods to transform points from the global coordinate system to the coordinate system of the section cut, and vice versa.

Export Section Cut Example

Export section cut properties to Mechanical APDL as a preintegrated composite beam.

```

model = db.active_model
model.update()

with open("D:\\tmp\\composite_sections.cdb", "w") as mapdl_file:
    for index, sc in enumerate(model.section_cuts.values()):
        # compute equivalent beam properties
        results = sc.compute_equivalent_beam_properties(check_status=True)
        sectype_command = sc.get_sectype_command_from_sectional_properties(
            properties=results.properties,
            stiffness_matrix_position="elastic center",
            stiffness_matrix_angle="elastic axes",
            mass_matrix_position="center of gravity",
            mass_matrix_angle="principal axes",
            sectype_id=index+1
        )
        mapdl_file.write(sectype_command)

```

2.1.14.4.4. Limitations

This feature has the following limitations:

- The computation becomes expensive (RAM and time) if the section cut has many nodes (over 5000). The number of nodes can be reduced by combining plies with equal material and orientations.
- The default properties of variable materials are used for the calculation of the equivalent beam properties. For instance, the effect of draping is ignored if material properties vary with respect to the shear angle.

2.1.14.4.5. References

The computation of the respective sectional properties based on Ghiringhelli's theory (see [\[Ghir- inghelli et al. \(1994\)\] \(p. 369\)](#)) was compared with that of Becas. The comparison contains various cross sections with different materials and lay-ups, and the results are almost identical.

2.1.15. Sensors

A Sensor provides the evaluation of global results like price, weight, or area. Results can be evaluated for specific parts, materials or plies.

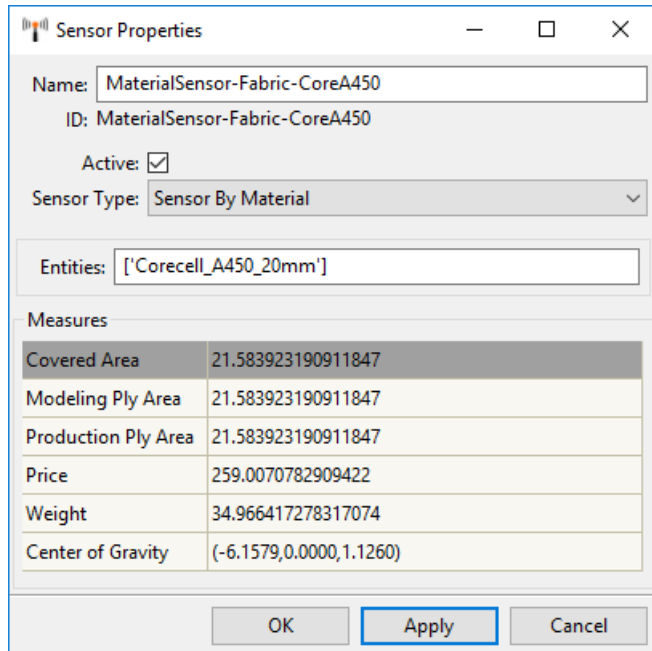
Figure 2.117: Sensor Properties

The **Sensor Properties** dialog contains the following options:

- **Name:** Name of the Sensor.
- **Active:** Set to false to suppress the Sensor computations.
- **Sensor Type:** Define the evaluation type.
 - **Sensor by Area:** Select one or several Element Sets or Oriented Selection Sets.
 - **Sensor by Material:** Select Fabric(s), Stackup(s) and/or Sublaminates. If a Fabric is selected, the plies in the Sublaminates are also considered in the evaluation; plies in a Stackup are not.
 - **Sensor by Modeling Ply:** Select one or more plies.
 - **Sensor by Solid Model:** Select one or more solid models. For a solid model sensor type, only weight and center of gravity are computed.
- **Entities:** Select the corresponding entities by clicking them in the Tree.
- **Measure:** Display results of different quantities.
 - **Weight:** Mass of the selected entity.
 - **Covered Area:** Surface area of a selected Element Set, Oriented Selection Set, or tooling surface area that is covered by the composite lay-up of the selected Material or Modeling Ply.
 - **Modeling Ply Area:** Surface area of all Modeling Plies of the selected entity.
 - **Production Ply Area:** Surface area of all Production Plies of the selected entity.

- **Price:** Price for the composite lay-up of the selected entity. The price per area is set under **Material Data > Fabrics** or **Material Data > Stackups**.
- **Center of Gravity:** Center of gravity of the selected entity in the global coordinate system.

2.1.16. Solid Models

Topics in this section:

[2.1.16.1. Solid Model](#)

[2.1.16.2. Imported Solid Model](#)

ACP knows two different types of solid models: the first type is simply called Solid Model and is based on an extrusion algorithm that generates a volume mesh from the shell mesh and its Composite Definitions. The second type is named Imported Solid Model and maps the Composite Definitions onto an external (imported) solid mesh.

Because of its geometrical limitations, you can only use the standard Solid Model for simple to moderately complex lay-up models and shapes. You can customize the extrusion of the lay-up using Extrusion Guides, Snap-To Geometries, and Cut-Off Geometries. Still, the extrusion can result in highly distorted layered solid elements if the shell reference surface is highly curved and the laminate is thick.

The Imported Solid Model is a good alternative because the solid mesh is generated independently of the lay-up. The solid mesh is loaded in ACP, and the lay-up (Composite Definitions) from ACP is mapped onto the external solid mesh. With the Imported Solid Model, you can choose to map the lay-up using layered or reinforcing elements. The latter eases the solid mesh constraints since it enables the use of any solid element type (brick, tetra, etc.). Meanwhile, layered elements require a solid mesh with brick or prism elements.

Figure 2.118: Solid Model Folder with a Standard Solid Model and an Imported Solid Model

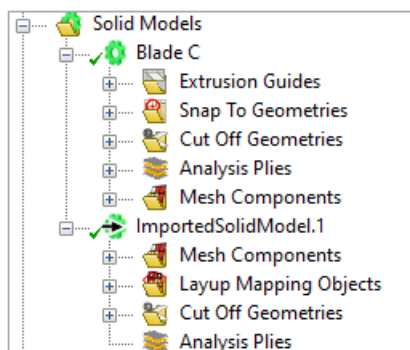

The context menu of the Solid Models object contains these actions:

- **Create Solid Model:** creates a new solid model object

- **Paste:** adds a new solid model object from the clipboard

Note:

The Imported Solid Models can only be created via the Workbench Project Schematic. See the [Solid Modeling \(p. 48\)](#) workflow section.

2.1.16.1. Solid Model

The Solid Model feature creates a layered solid element model from a composite shell model. The solid element model can be integrated into a Workbench workflow or exported for use outside of Workbench. [Analysis of a Composite Solid Model \(p. 314\)](#) explains the Solid Model workflow in Workbench, and [Guide to Solid Modeling \(p. 283\)](#) provides general information on solid modeling.

The settings for the solid model generation are adjusted under the **Solid Model** context menu item **Properties**. The [Solid Model Properties \(p. 185\)](#) dialog covers what Element Sets are extruded, the extrusion method, Drop-Off elements handling and numbering offsets, among other things.

You can use Extrusion Guides, Snap-To, and Cut-Off Geometries to shape the Solid Model as desired. They are specified in the respective subfolders in the **Solid Model** Tree View. The **Analysis Plies** sub-folder shows which plies are incorporated in the Solid Model. The sub-folder **Mesh Components** contains internal Element Sets which are created during the extrusion.

Figure 2.119: Solid Model Feature in the Tree View

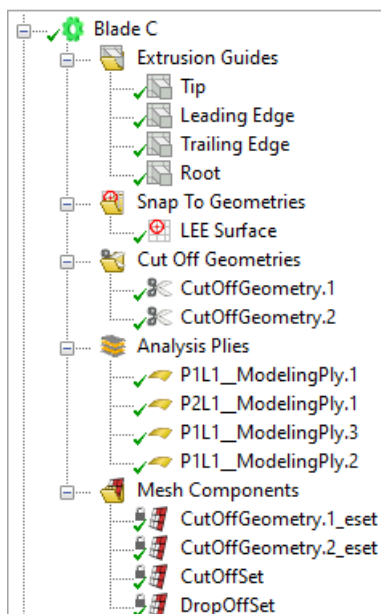

Subtopics:

- [2.1.16.1.1. Properties](#)
- [2.1.16.1.2. Export Solid Model](#)
- [2.1.16.1.3. Extrusion Guides](#)
- [2.1.16.1.4. Snap-To Geometry](#)
- [2.1.16.1.5. Cut-Off Geometry](#)

2.1.16.1.6. Mesh Components

2.1.16.1.7. Material Handling for Different Extrusion Methods

2.1.16.1.8. Save & Reload Solid Models

2.1.16.1.9. Node-based Thicknesses

2.1.16.1.1. Properties

The **Solid Model Properties** dialog is divided into the following tabs:

2.1.16.1.1.1. General

2.1.16.1.1.2. Drop-Offs

2.1.16.1.1.3. Export

2.1.16.1.1.1. General

The **General** tab has the following properties:

Figure 2.120: Solid Model Properties - General

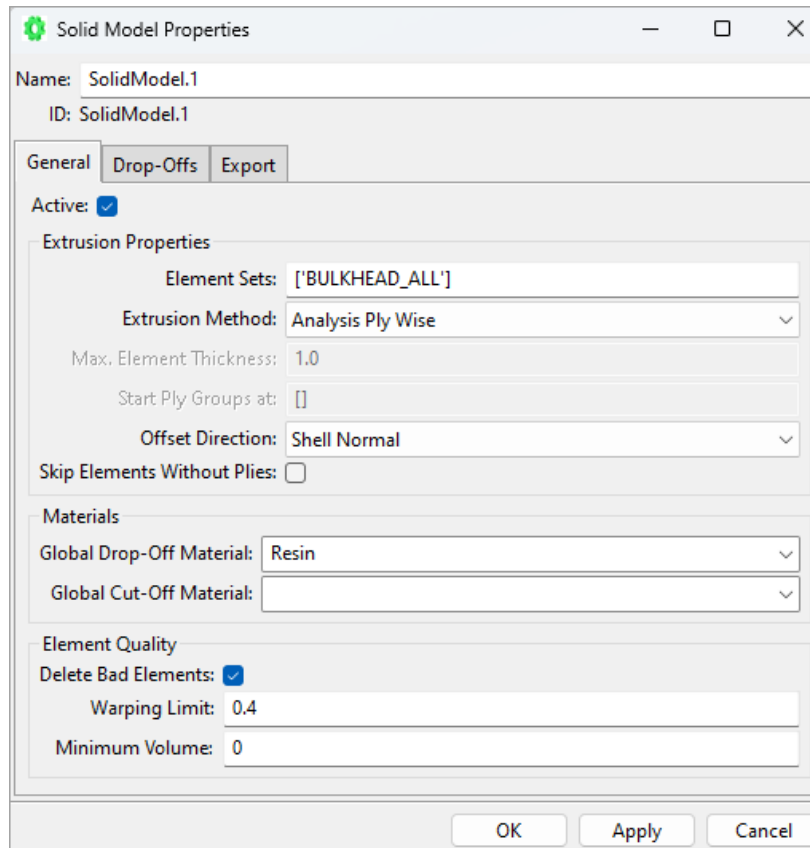

Element Sets

Starting with a shell model and the lay-up definition, the shell elements are extruded to a layered solid element model. Select an Element Set to define the region of the extrusion.

Important:

The mid-offset option of Element Sets is not supported for Solid Model extrusion. The ply definition must be defined without this option to obtain the correct solid model position.

Extrusion Properties

The lay-up extrusion can be organized in different ways to merge plies with different criteria:

- **Extrusion Method:**

- **Analysis Ply Wise:** Extrude each Analysis Ply as one solid element layer.
- **Material Wise:** All sequential plies containing the same material are grouped in one solid element layer. A maximum element thickness can be specified that will subdivide the single element layers if necessary.
- **Modeling Ply Wise:** Extrude each Modeling Ply as one solid element layer (for example, every Stackup or Sublaminates is extruded as one solid element layer).
- **Monolithic:** Extrude the whole lay-up in one solid element layer.
- **Production Ply Wise:** Extrude each Production Ply as one solid element layer if possible. Depending on the model topology, monolithic Modeling Groups may be split in order to ensure the cohesion of the resulting solid model.
- **Specify Thickness:** Plies are grouped by iterating through the laminate from the inside out..
- **User Defined:** Plies are grouped by iterating through the laminate from the inside out.
- **Sandwich Wise:** Plies on either side of a core material are grouped into single element layers. The core material is extruded as one element layer.

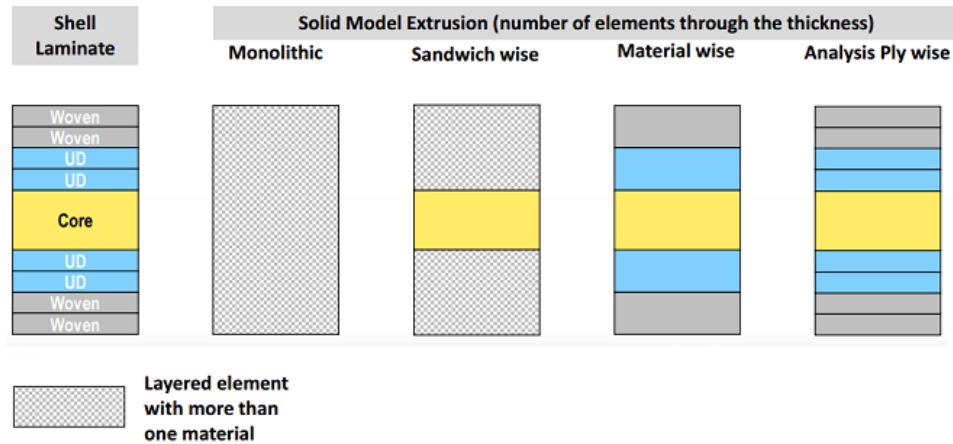
Figure 2.121: Illustration of Solid Model Extrusion Methods

For extrusion methods other than analysis ply-wise, see [Material Handling for Different Extrusion Methods \(p. 207\)](#).

- **Max Element Thickness:** Thickness at which a new Modeling Group will be introduced. If a single ply is thicker than this value it is split into layers of equal thickness no thicker than this value.
- **Start Ply Groups at:** A new Modeling Group is introduced each time the iteration meets one of the plies specified in this option (User Defined Extrusion Method only)
- **Offset Direction:** With the **Surface Normal** option, the extrusion direction is re-evaluated after each row of solid elements. With **Shell Normal** option, the extrusion direction stays defined as shell normal.

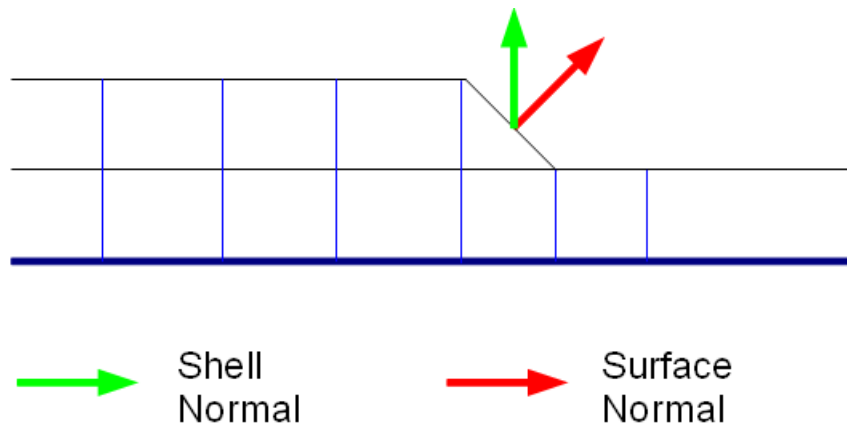
Figure 2.122: Offset Direction - Schema

An example of both options is shown in the following figure:

Figure 2.123: Offset Direction - Example

The effect is visible in the element rows above the drop-off elements.
Solid Model with Surface Normal Direction

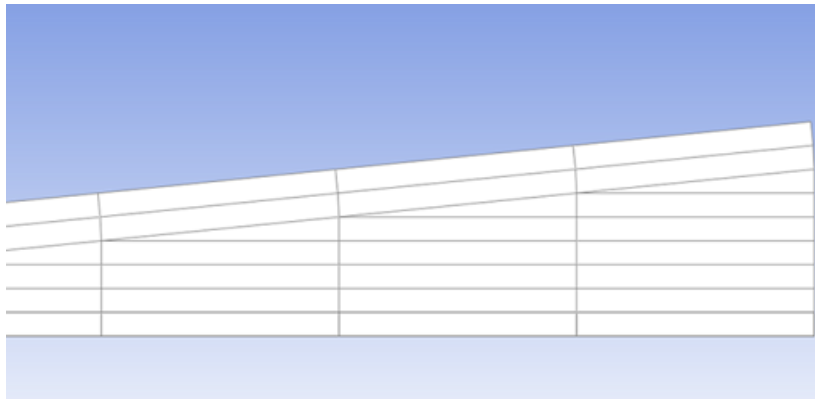

Solid Model with Shell Normal Direction

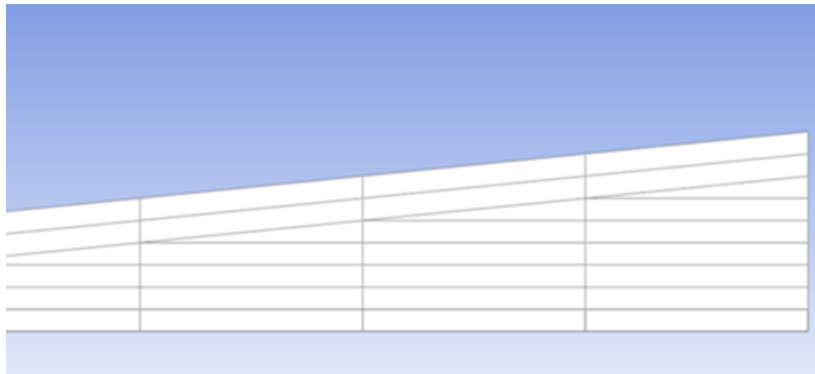

- **Skip Elements Without Plies:** Enable this option to automatically remove elements without plies from the region of extrusion. This ensures that no drop-off elements are created between the elements without plies and the adjacent elements. An application example is when holes are filled and meshed but do not contain a lay-up.

Drop-Offs and Cut-Offs

The **Drop-Offs and Cut-Offs** section controls the global material handling for Drop-Off and Cut-Off elements in the solid model. The following options are available:

- **Global Drop-Off Material:** This setting is used when the material handling settings for fabrics and stackups are set to **Global**.
- **Global Cut-Off Material:** This setting is used when the material handling settings for fabrics and stackups are set to **Global**.

Element Quality

ACP performs shape checks during the solid model generation. The checks are similar to [Element Shape Testing](#) in Mechanical APDL, and bad elements are deleted if they fail the check. You can adjust some of the limits and tolerances:

- **Delete Bad Elements:** When enabled, ACP will perform shape checks. Disable this option to suppress the shape checks.

- **Warping Limit:** Solid elements with a [warping factor](#) above this limit are removed from the solid model. The default value is 0.4. Twisting the top face of a unit cube by 22.5° and 45° relative to the base produces warping factors of about 0.2 and 0.4, respectively.

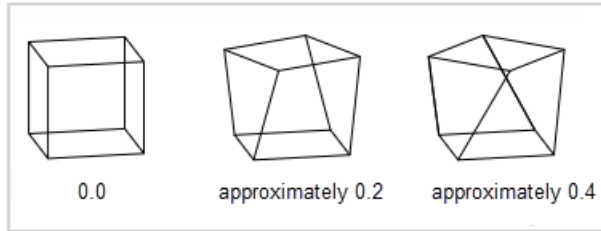

- **Minimum Volume:** Elements with a volume equal to or smaller than this limit are deleted. The default value is **0** so only elements with a negative or zero volume are removed. You can adjust this parameter accordingly should the solver produce error messages about small elements with a volume close to zero. For instance, the Mechanical APDL solver logs this error: `*** ERROR *** Zero volume in element...`

2.1.16.1.1.2. Drop-Offs

The Drop-Offs Tab has the following properties:

Figure 2.124: Solid Model Properties - Drop-Offs

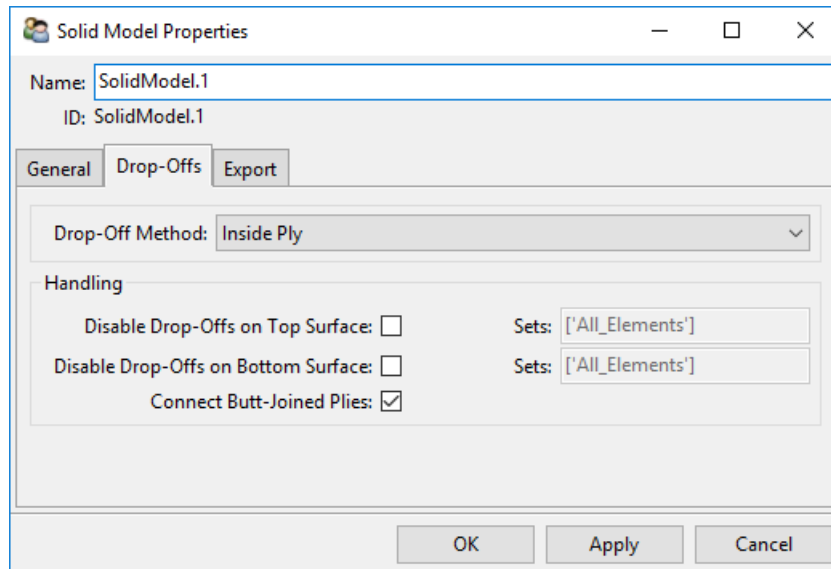

- **Drop-Off Method:** Define the ply's Drop-Off before or after the edge.

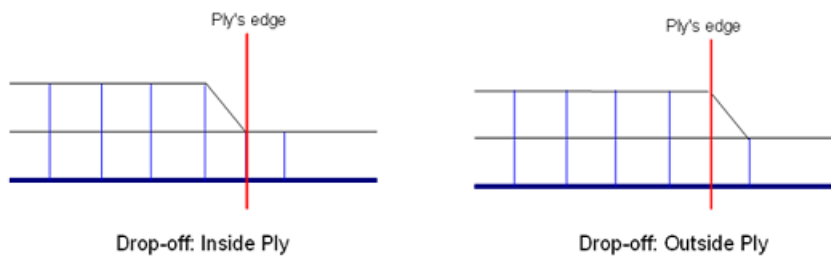

- **Disable Drop-Offs on Top Surface:** Deactivates Drop-Off elements on the top face sheet of the laminate for the selected (oriented) Element Sets.
- **Disable Drop-Offs on Bottom Surface:** Deactivates Drop-Off elements on the bottom face sheet of the laminate for the selected (oriented) Element Sets.

Figure 2.125: Disable Drop-Offs

Disable Drop-Offs option deactivated

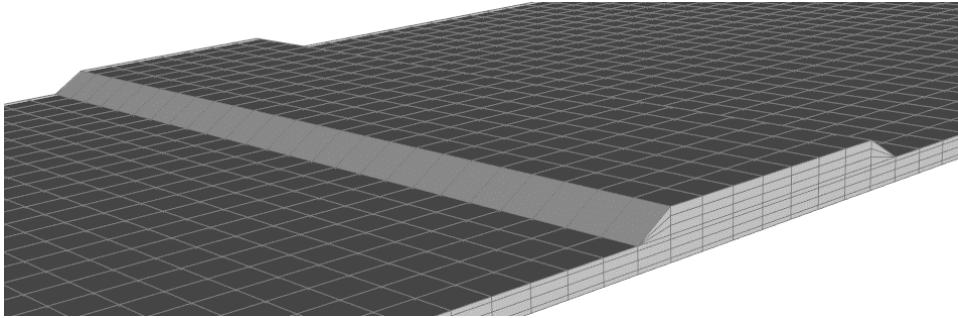

Disable Drop-Offs option activated

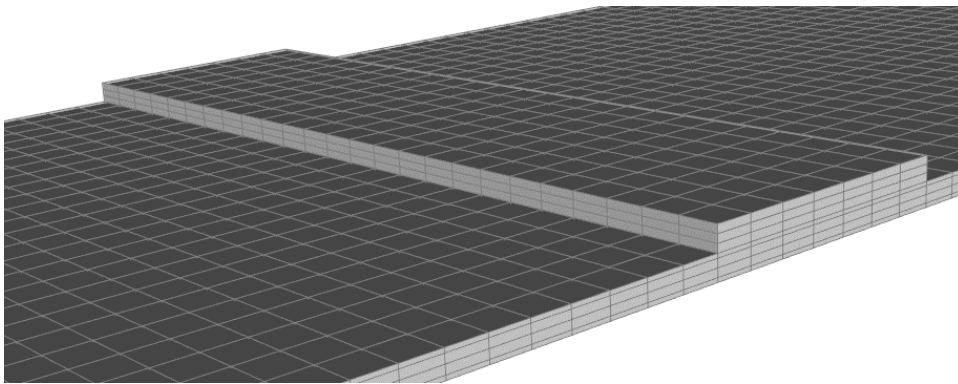

- **Connect Butt-Joined Plies:** If a composite layer ends away from a mesh boundary, it tails off with a Drop-Off Element. These Drop-Off elements are degenerated brick elements that are reduced from bricks into prisms. This option can prevent an element Drop-Off of two adjacent, sequential plies in the same modeling group. By default, it is active.

The feature is limited to plies that appear sequentially in the same Modeling Group. It is not possible to connect all butt-jointed plies that are arranged in a circle. This is a known limitation.

An example of a sandwich structure with divided core material is shown below to demonstrate the use of a ply connection.

Figure 2.126: Connect Butt-Jointed Plies

Connect Butt-Jointed Plies activated

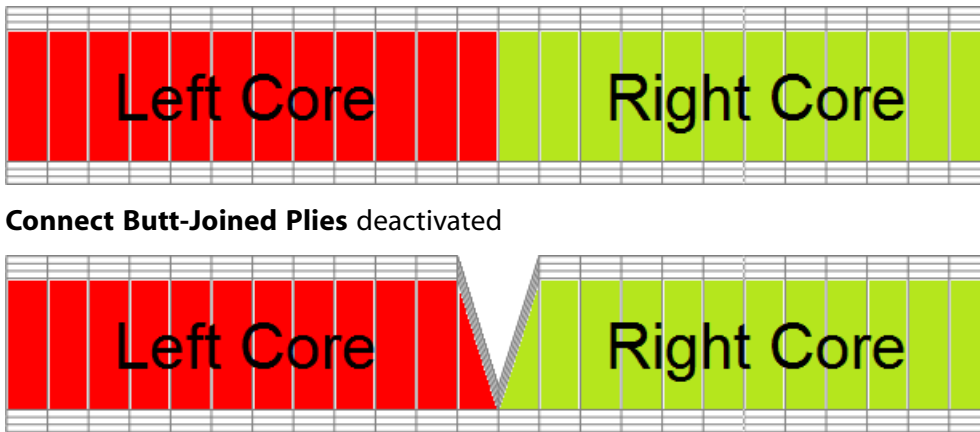

Connect Butt-Joined Plies deactivated

2.1.16.1.1.3. Export

The Export Tab has the following properties:

Figure 2.127: Solid Model Properties - Export

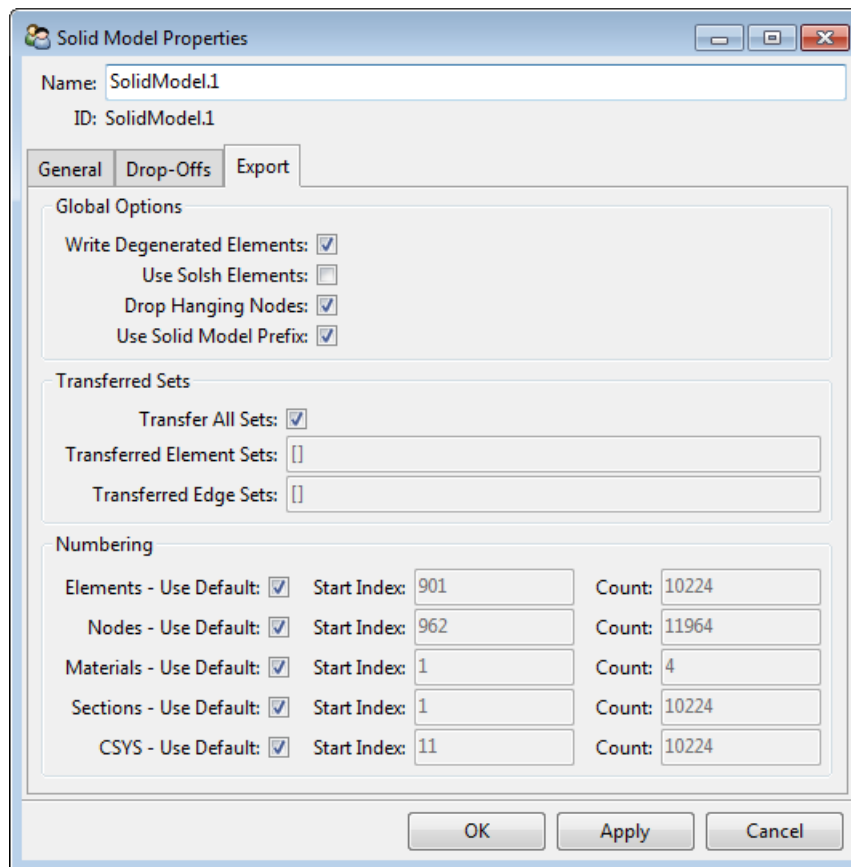

Global Options

- **Write Degenerated Elements:** Include Drop-Off elements and Cut-Off elements in the solid model export. Deactivating this option can lead to holes in the mesh and prevent import into Mechanical. Deactivating this option is not advised during a Workbench workflow.

Figure 2.128: Write Degenerated Elements

Export with Drop-Off Elements

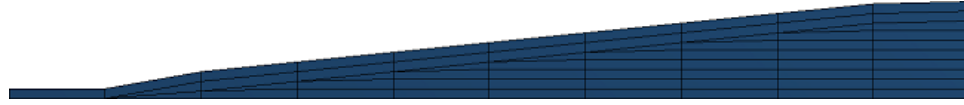

Export without Drop-Off Elements



- **Use SOLSH Elements:** Create the model with Solid-Shell elements ([SOLSH190](#)).
- **Drop Hanging Nodes:** Remove hanging nodes from model before solve (default on).

Hanging nodes are not connected to all the neighboring elements. Hanging nodes can occur when quadratic hexahedral, tetrahedral, and prism elements are connected together. Hanging nodes can lead to discontinuous deformation fields and are therefore not desirable. When this option is active, element edges containing a hanging node are described as a linear shape function. The following figure shows a quadratic tetrahedral element on top of a quadratic hexahedra element. There is a hanging node on the tet element, highlighted by the red square:

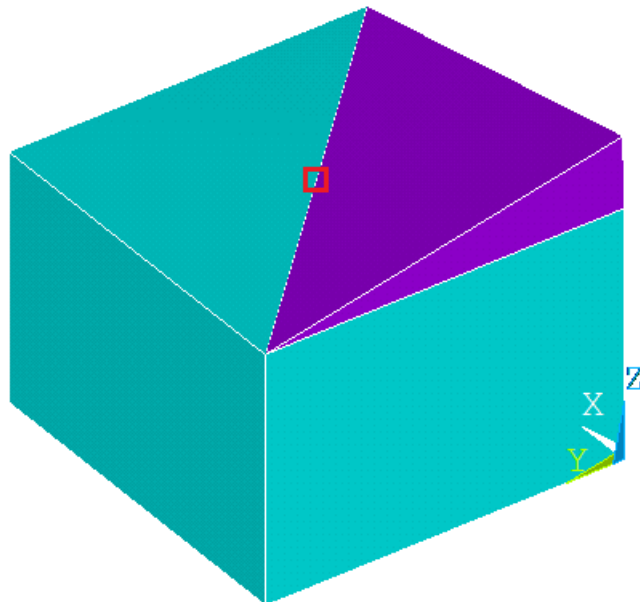
Figure 2.129: Quadratic Tetrahedral Element on Top of a Hexahedral Element

- **Use Solid Model Prefix:** This option makes element components begin with the name of the defined solid model. For example, if the solid model is `BULKHEAD`, the elements are grouped into components in the following way:

CMBLOCK,BULKHEAD_P9L1_Plies_Top,ELEM, 600! users element component definition

Transferred Sets

- **Transfer All Sets:** All Edge and Element Sets are transferred.
- **Transferred Element Sets:** Specify Element Sets for transfer. Element Sets become two separate element components with the designation `_TOP` and `_BOT`. One element component coincided with the original Element Set and the other one lies at the end of the extrusion path.
- **Transferred Edge Sets:** Specify Edge Sets for transfer. Edge Sets are extruded to form surfaces (an Edge Set transfers to a surface element component).

Figure 2.130: Transferred Element Sets in Mechanical

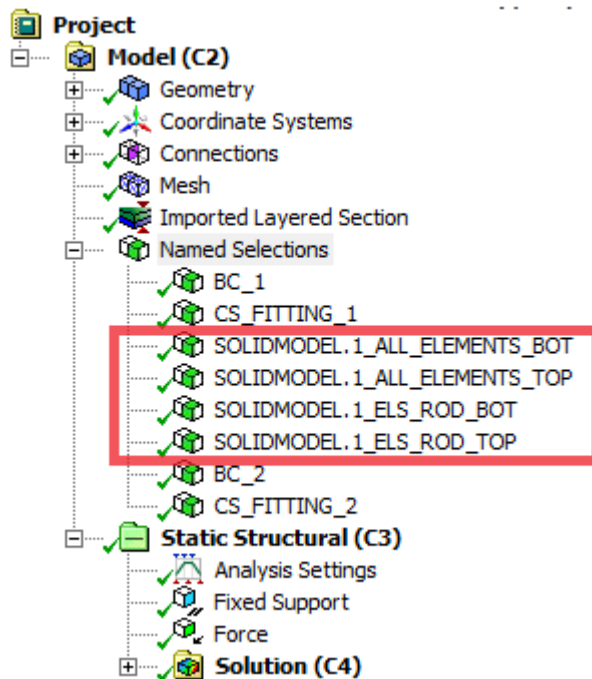

Numbering Offset

ACP automatically performs entity numbering within your Workbench project. To avoid overlap, entities of multiple solid models in one ACP setup are automatically renumbered. When different ACP or Mechanical models are combined in a single analysis system, there is also automatic renumbering.

The automatic renumbering is activated by default and can be deactivated in the properties of the downstream Mechanical Model cell (see **Renumber Mesh Nodes and Elements Automatically**).

The entity numbering offset can also be controlled manually. Deactivate the Default option to define the offset manually for each of the entities (elements, nodes, materials, sections, coordinate systems). The numbering starts at the defined index and is incremented by one at a time.

Figure 2.131: Properties of the ACP-Pre Setup Cell in the Project Schematic

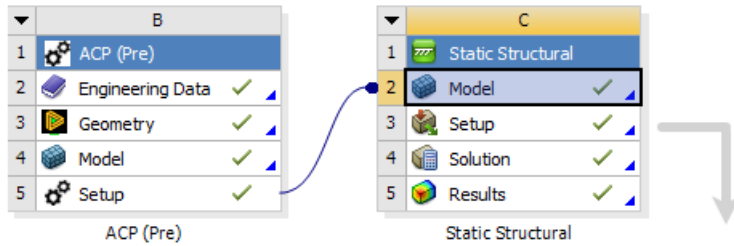

	A	B
1	Property	Value
2	General	
3	Component ID	Model 1
4	Directory Name	SYS
5	Notes	
6	Notes	
7	Used Licenses	
8	Last Update Used Licenses	ANSYS Academic Associate
9	System Information	
10	Physics	Structural
11	Analysis	Static Structural
12	Solver	Mechanical APDL
13	Mesh	
14	Save Mesh Data In Separate File	<input type="checkbox"/>
15	General Model Assembly Properties	
16	Length Unit	m
17	Object Renaming	Based on Syste...
18	Transfer Settings for ACP (Pre) (Component ID: Setup)	
19	Renumber Mesh Nodes and Elements Automatically	<input checked="" type="checkbox"/>
20	Transfer Type	Solid

2.1.16.1.2. Export Solid Model

The context menu of **Solid Model** and **Imported Solid Model** enables you to export the solid mesh itself or the skin (envelope) of the mesh in different formats.

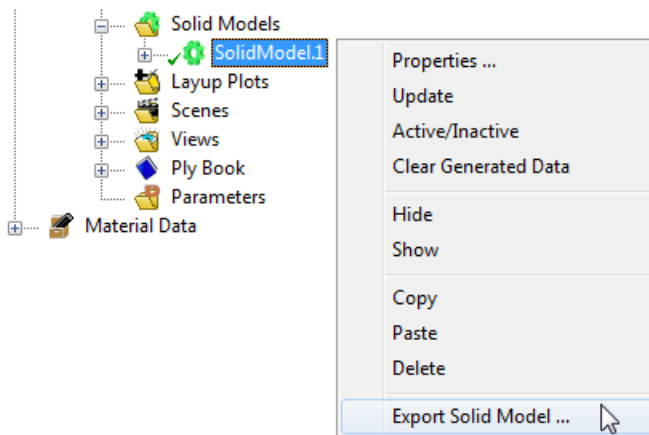

You can export the **skin** of the solid model as STEP, IGES, STL, or Mechanical APDL (CDB). These representations can be used, for instance, to construct the geometry of adjacent structures to

the solid model or to construct the geometry of filling material in an airfoil structure. Note that the STEP and IGES geometries are built from a mesh based tessellation of the skin. Therefore, it might be worth to work with the STL format and the usage of reverse engineering tools to construct a proper geometrical representation. The CDB format brings the benefit that you work without a geometry.

The analysis solid model itself can be exported as a CDB file. Element shape checking is deactivated in the exported file. Check that the material properties are consistent with the mesh units of the CDB file.

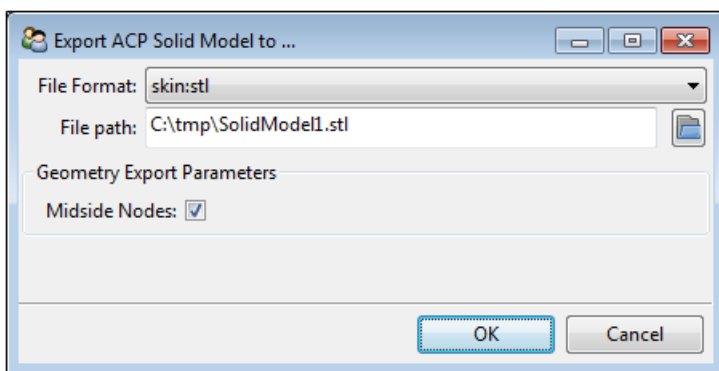

Midside Nodes: If available and active, the tessellation of the mesh includes the midside nodes of the quadratic elements. If not, only the corner nodes are considered. This option is only available for the formats skin:stp, skin:igs and skin:stl.

2.1.16.1.3. Extrusion Guides

Solid Model generation for curved geometries and thick lay-ups can lead to boundary edges which are extruded in undesirable directions. For example, the extrusion of a dome with a hole at the top results in a solid model with a hole that is not cylindrical. The Extrusion Guide feature allows you to control the extrusion direction of the edges in order to rectify this. The edge of the hole can be used as an Extrusion Guide in the vertical direction to create a cylindrical hole.

Figure 2.132: Extrusion with and without an Edge Set Guide

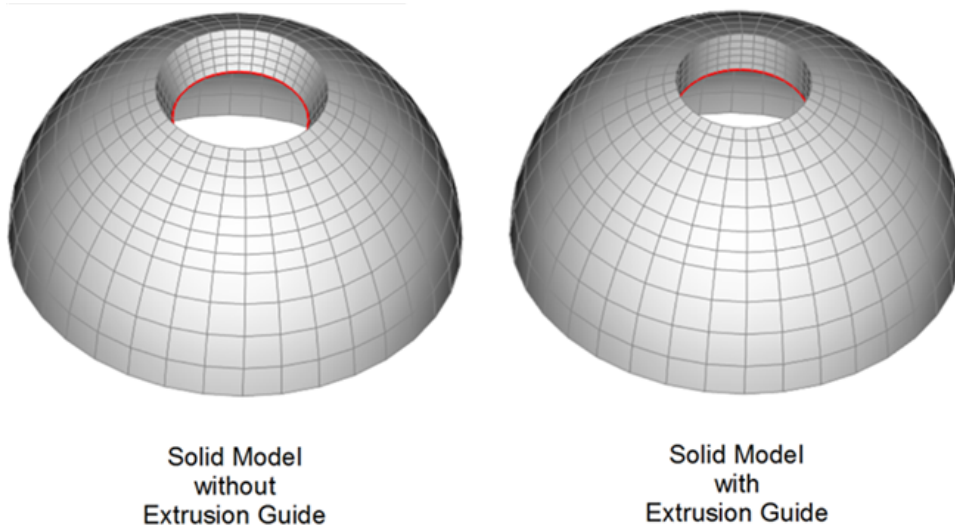

Solid Model
without
Extrusion Guide

Solid Model
with
Extrusion Guide

Multiple Extrusion Guides can be used for one Solid Model. The extrusion itself is controlled with an edge set and a direction vector or with a geometry. The Extrusion Guide feature also contains a Curvature Control. The **Extrusion Guide Properties** dialog has the following options:

Figure 2.133: Extrusion Guide Properties

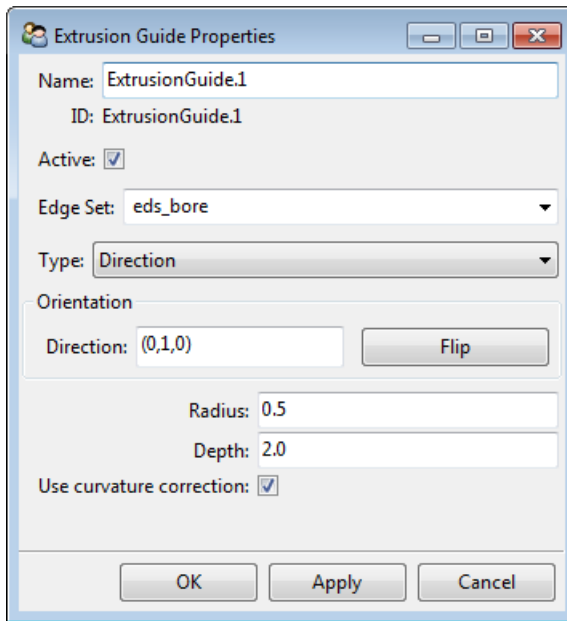

- **Edge Set:** Define the Edge Set along which the Extrusion Guide acts.
- **Type:** The type of Extrusion Guide.
 - **Direction:** Defines a direction vector of the extrusion direction of the Edge Set.
 - **Orientation Direction:** By default, the normal direction of the Edge Set is calculated and defined when an Edge Set is selected. It can also be entered manually.
 - **Geometry:** CAD file of a boundary surface is used to define the extrusion path.
 - **CAD Geometry:** Select a previously generated [Virtual Geometry \(p. 101\)](#). See [CAD Geometries \(p. 99\)](#) for information on how working with geometries impacts system performance.
 - **Free:** No extrusion path is defined but a curvature correction can be activated independently.
- **Radius:** Controls the sphere of influence for mesh morphing.
- **Depth:** controls the bias of the mesh morphing.
- **Use Curvature Correction:** Apply a curvature correction during the solid model extrusion which results in a smoother extruded surface. Under certain circumstances, deactivating curvature correction can lead to better extrusion results.

Extrusion Guides are executed in the order they appear in the Tree. This has significant effects when Extrusion Guides intersect. You can change the order of Extrusion Guides from the Tree View, in one of the follows ways:

- Use the cut-and-paste options in the context menu.

- Use the cut (**Ctrl+X**) and paste (**Ctrl+V**) hotkeys.
- Use the mouse to drag-and-drop the Extrusion Guides.
- Use the **Reorder** option in the context menu, as shown below.

Figure 2.134: Reordering Extrusion Guides

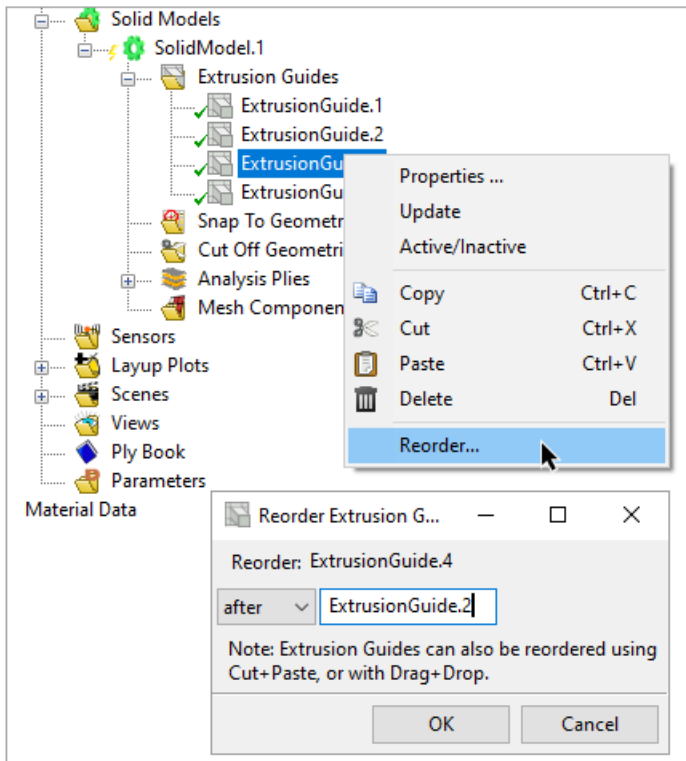

2.1.16.1.3.1. Mesh Morphing

The generation of a solid model is by extrusion of a shell mesh. By default, extrusion is in the direction of the shell normal direction. The 2D shell mesh is used as a base for the 3D solid element mesh, which can have one or more element layers depending on the ply thickness and extrusion method.

The Extrusion Guide only affects the extrusion of the element edges that are part of the guided Edge Set. It is either defined by an Edge Set and direction vector or by an Edge Set and a CAD geometry. While the CAD geometry already is a surface, the Edge Set and direction vector helps define a surface. In both cases, these surfaces serve as target surfaces in the extrusion.

The guided edge is initially extruded in the normal direction. Then, the nodes on the resulting free surface are moved to coincide with the target surface of the Extrusion Guide.

Mesh morphing is a way to control the propagation of the Extrusion Guide effect through the entire mesh.

Mesh morphing is governed by the morphing law, shown in [Equation 2.1 \(p. 198\)](#). It relates the displacement of internal nodes to the displacement of a node of the guided free surface. Mesh morphing can be controlled with the two parameters:

- **Radius:** All elements within the defined **Radius** from the Edge Set are extruded with a mesh morphing correction.
- **Depth:** Defines the bias of the mesh morphing (linear with 1, quadratic with 2,...).

$$m_i = m_0 \cdot \left[1 - \left(\frac{d_i}{\text{Radius}} \right)^{\text{Depth}} \right] \quad (2.1)$$

where:

m_0 is the distance a node on the free surface has to move in-plane to coincide with the Extrusion Guide.

m_i is the distance the inward node of the i^{th} shell element moves in-plane as a result of the mesh morphing.

d_i is the distance between the node in the guided Edge Set and the inward node of the i^{th} shell element.

Figure 2.135: Mesh Morphing Diagram

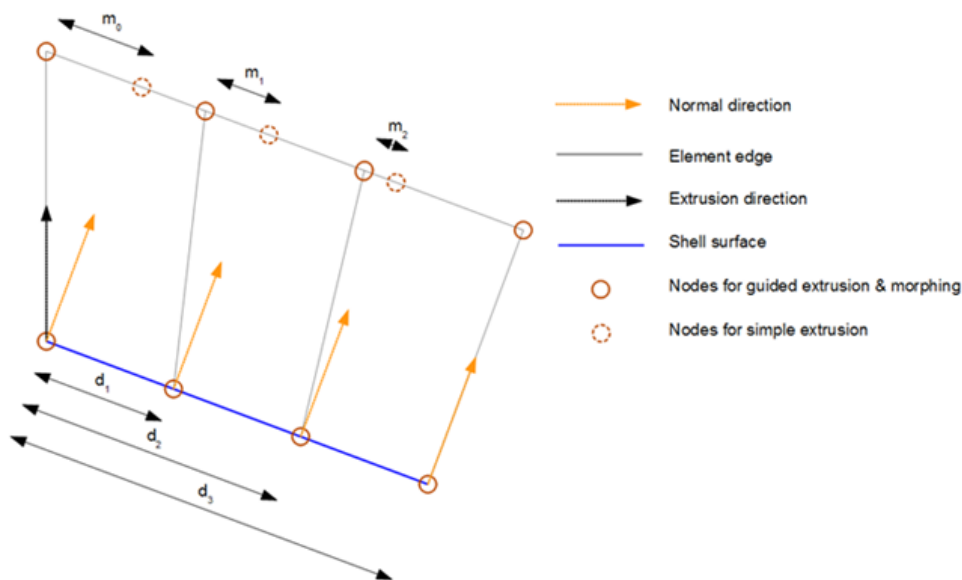

2.1.16.1.3.2. Extrusion Guide Examples

The following is an example of a direction-type Extrusion Guide with different mesh morphing radii. The location of the edge set is indicated by the circle in the bottom left corner. The mesh morphing is only applied to nodes on the shell surface whose distance to the Edge Set is smaller than the radius.

Figure 2.136: Example of a Direction-type Extrusion Guide with Different Mesh Morphing Radii

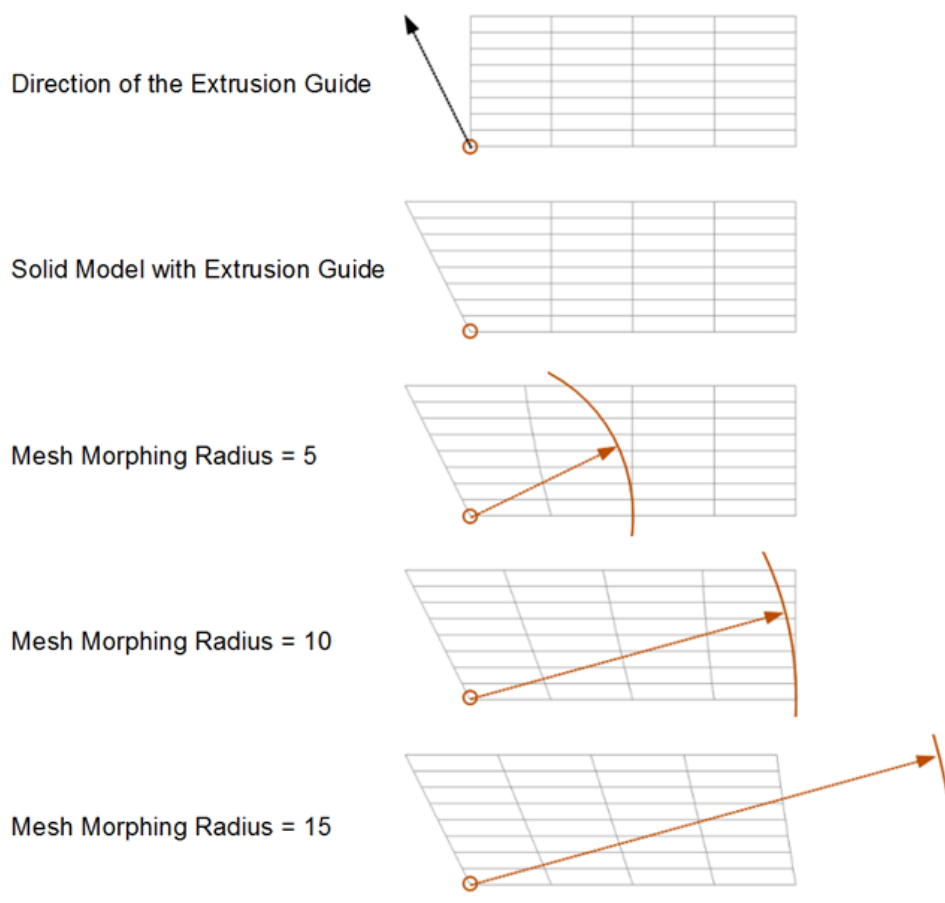

The following is an example of a geometry-type Extrusion Guide with different mesh morphing depths:

Figure 2.137: Example of a Geometry-type Extrusion Guide with Different Mesh Morphing Depths.

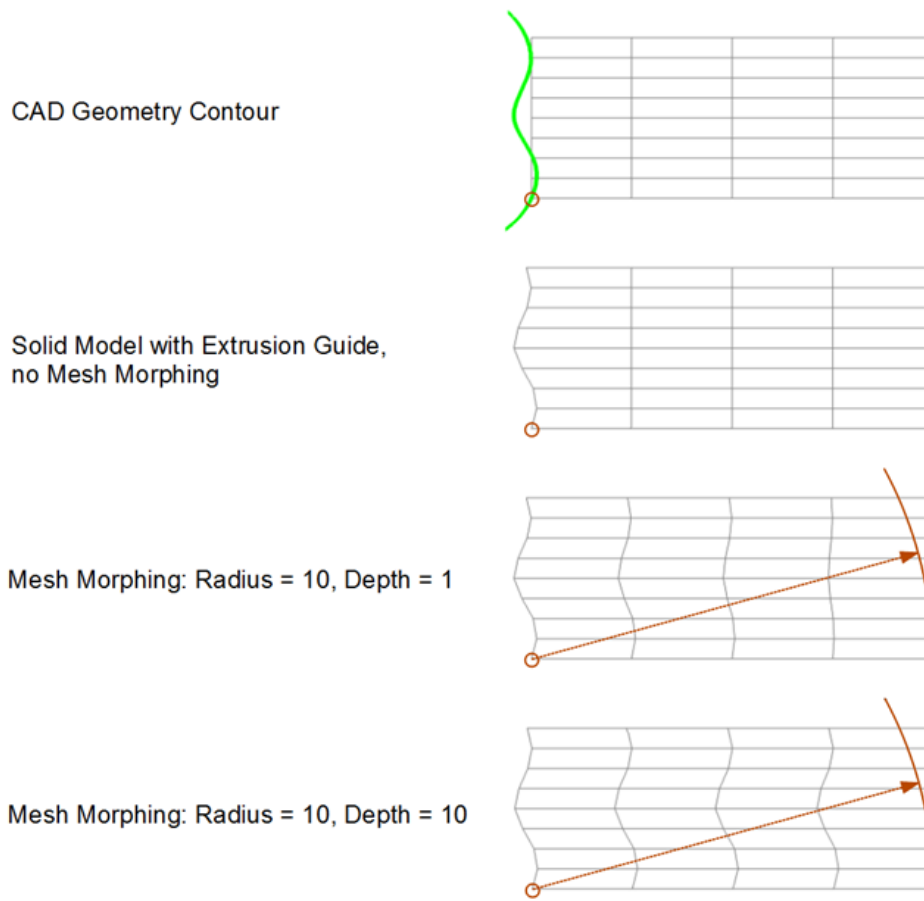

2.1.16.1.4. Snap-To Geometry

The Snap-To Geometry feature can alter an extruded Solid Model to align with an imported [CAD Geometry](#) (p. 99). The layered Solid Model is locally stretched or compressed so that its selected faces coincide with the CAD geometry. Multiple Snap-To Geometries can be assigned to one Solid Model. The adaptation occurs at the first intersection that is found. See [CAD Geometries](#) (p. 99) for information on how working with geometries impacts system performance.

The feature is only applied to the selected Oriented Selection Set and its selected face (top or bottom). The normal orientation of the Oriented Selection Set defines which face is top or bottom. The height of all the elements through the thickness is altered to an even distribution.

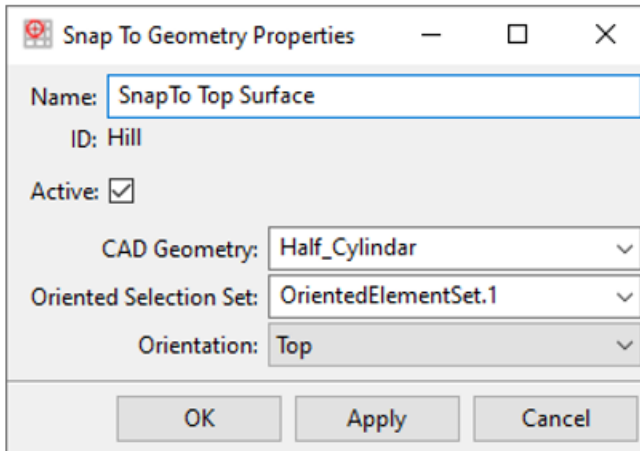

In the following example, the first picture shows the extrusion without any Snap-To Geometry operation. The lay-up is defined from two Oriented Selection Sets which point in opposite directions. In the second figure, the first Modeling Ply (oriented to the top) is defined to be extruded to a CAD Geometry. Only the nodes which meet the surface are extruded until the surface. The other nodes are extruded normally. The second Modeling Ply is extruded to another CAD Geometry in the last figure. For both cases, the orientation of the Snap-To Geometry operation must be top as the Oriented Selection Sets both point outward.

Figure 2.138: Extrusion without Snap Operation

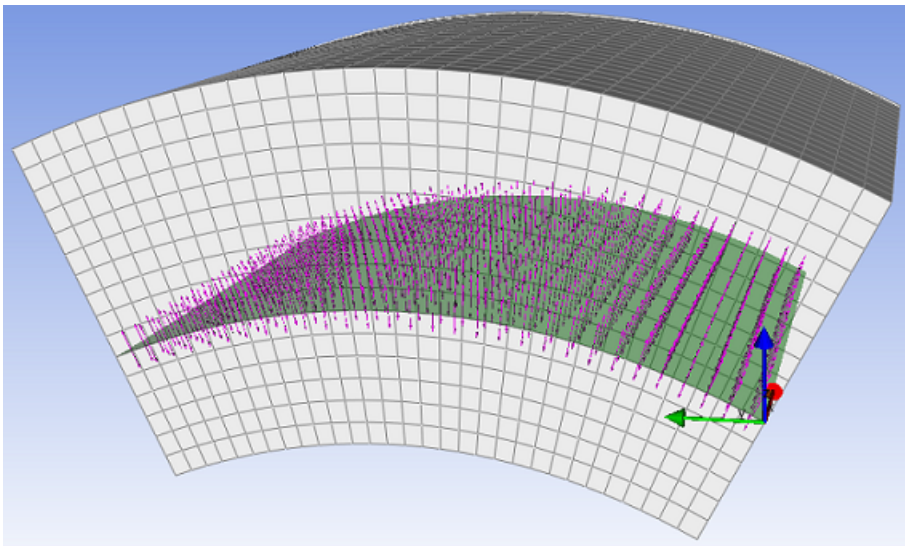
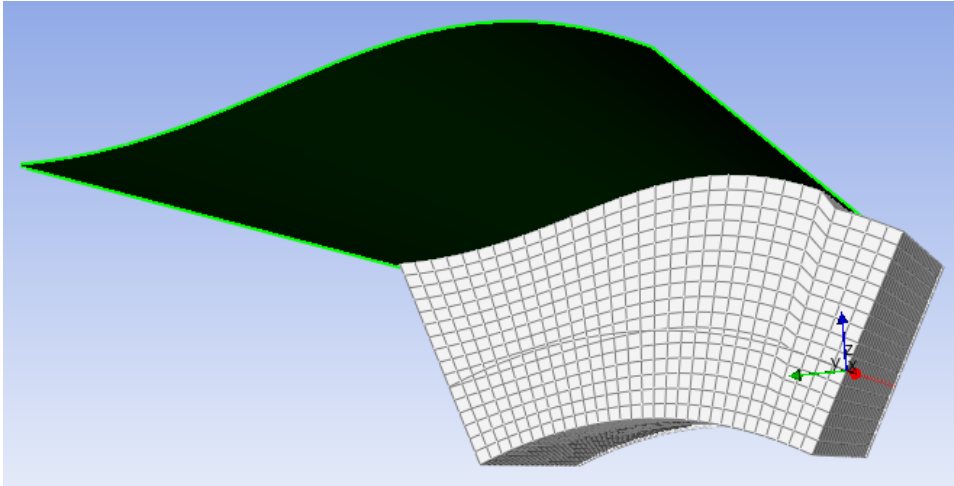
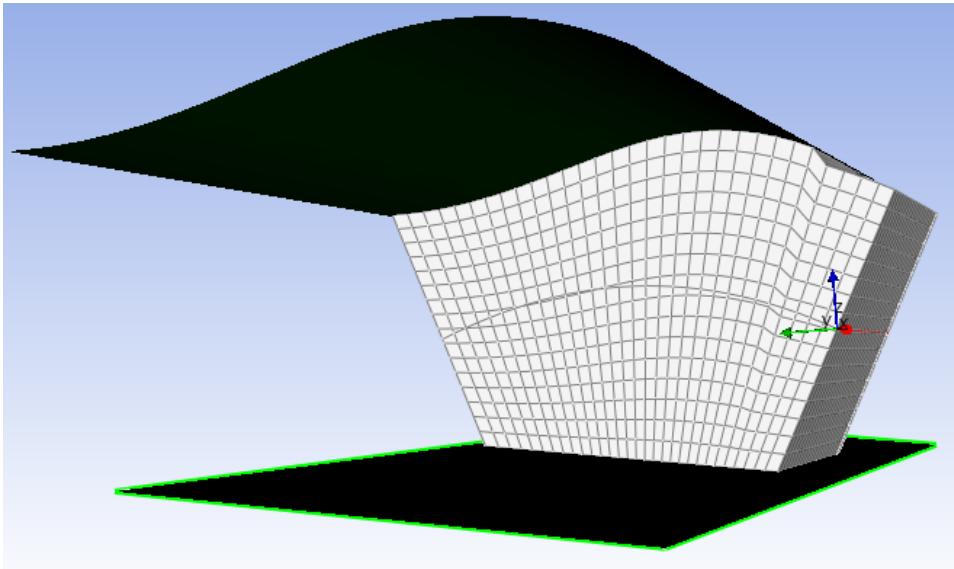

Figure 2.139: Extrusion with Snap-To Geometry at the Top (Shell Geometry also Displayed)**Figure 2.140: Extrusion with Snap-To Geometry at the Top and Bottom (Shell Geometry also Displayed)**

Caution:

The *Snap-To Geometry* operation occurs after the Extrusion Guide operations. It is possible that the nodes moved during the Extrusion Guide operations are translated again, and do not match with the previous Extrusion Guide definition.

2.1.16.1.5. Cut-Off Geometry

The Cut-Off Geometry feature uses [CAD Geometries \(p. 99\)](#) to shape the Solid Model by cutting off elements. The operation is analogous to machining a composite part after curing. Refer to [Guide to Solid Modeling \(p. 283\)](#) for more information. The following figures illustrate the Cut-Off Geometry feature:

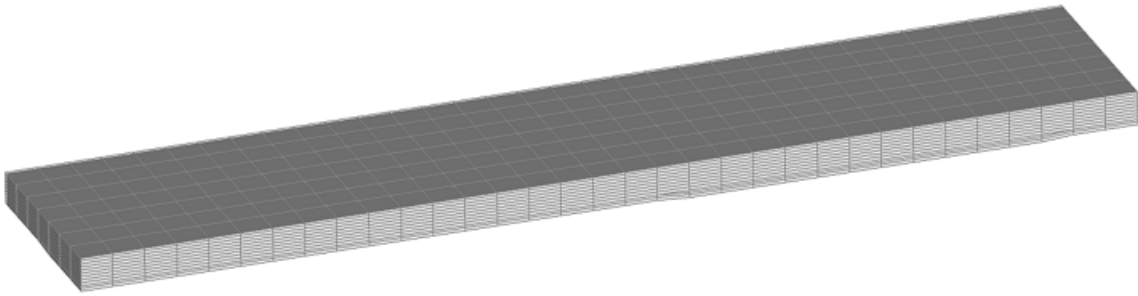
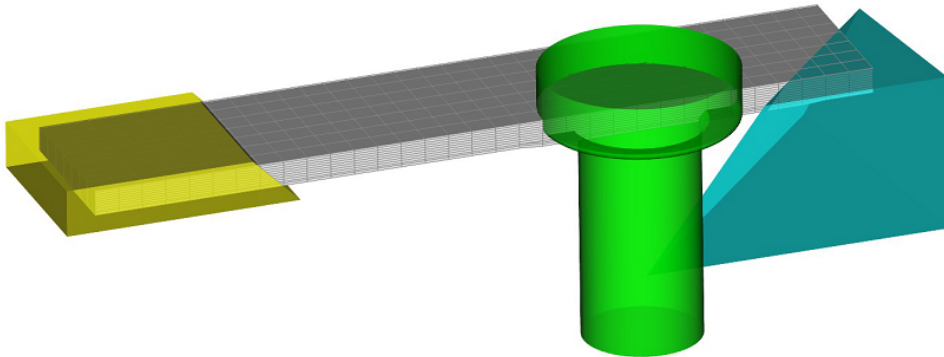
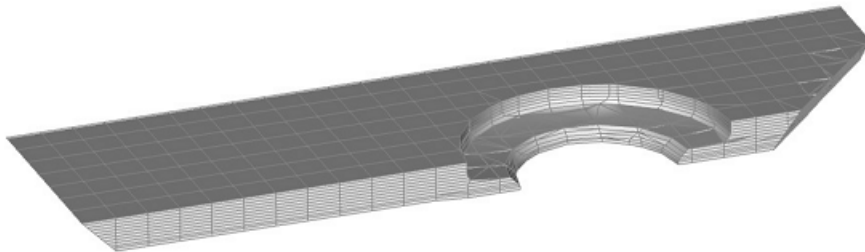
Figure 2.141: Extruded Solid Model**Figure 2.142: Cut-Off Geometries Shown Alongside Extruded Solid Model****Figure 2.143: Solid Model with Cut-Off Features**

2.1.16.1.5.1. Defining Cut-Off Geometry

Add a Cut-Off Geometry by selecting **Create Cut-Off Geometry** in the context menu of the Cut-Off Geometry folder.

Define the Cut-Off operation with either a CAD surface geometry or CAD body geometry. The orientation flag specifies which side of the surface or the body the elements are cut off. The up orientation specifies that elements in the reverse normal direction of the geometry are cut off. A visualization of the surface normal direction of a CAD body geometry can be displayed with the **Show Normals** button in the toolbar.

You can use multiple Cut-Off Geometries for one solid model. The cut offs are applied sequentially in order of Cut-Off Geometries creation.

The following properties must be defined in the **Cut-Off Geometry Properties** dialog:

Cut-Off Geometry Properties

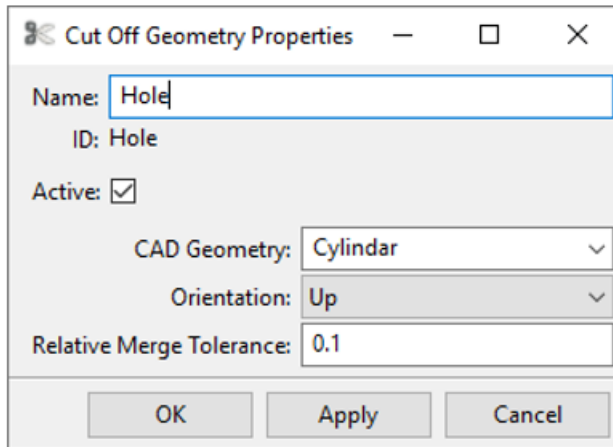

- **CAD Geometry:** CAD geometry for surface or body geometry.
- **Orientation:** Determines the cutting orientation of a surface/body geometry.

Figure 2.144: Cut-Off Geometry Normal Direction

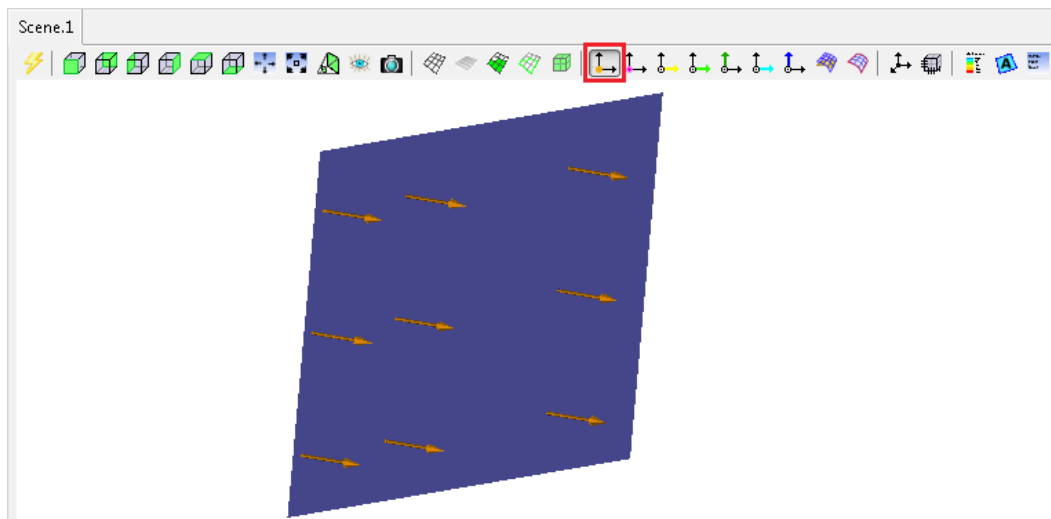

- **Relative Merge Tolerance:** Set the merging tolerance for neighboring nodes relative to the element size. If two nodes fall within this tolerance they are merged, which avoids very small element edges.

Note:

Cut-Off operations are computationally intensive, so it is important to define your geometries efficiently. The Cut-Off algorithm runs faster if you create a for each part instead of creating a single geometry containing all parts. This is because ACP, prior to running the calculation, filters out all extraneous points and elements. The figure below illustrates the principle: Instead of one large geometry, three Cut-Off geometries have been added, one for each feature.

Figure 2.145: Example of three Cut-Off geometries

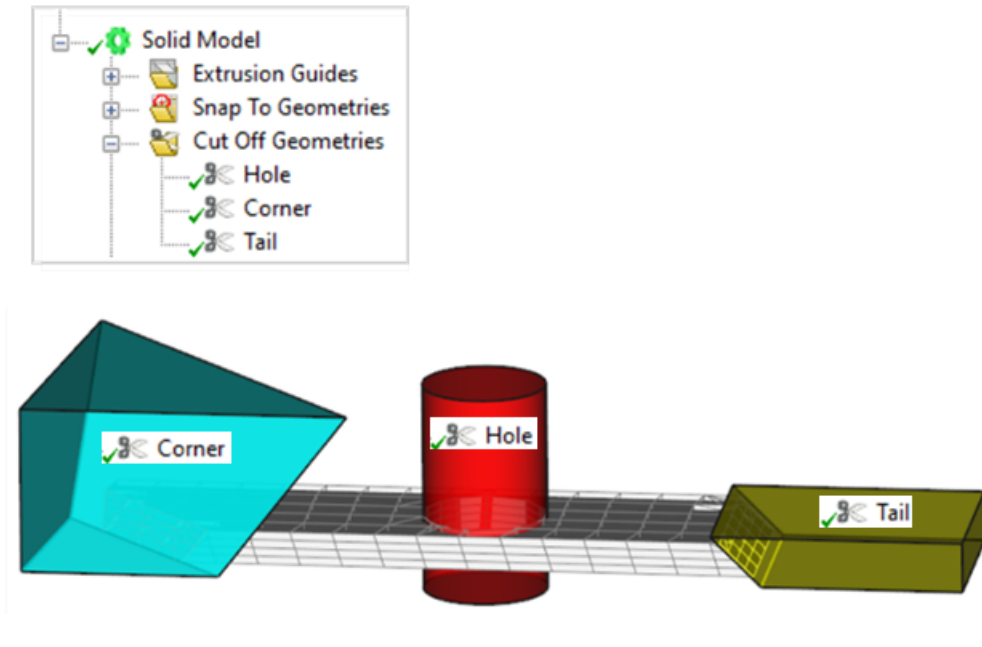

2.1.16.1.5.2. Decomposition of Degenerated Elements

The cutting operation can reshape elements in such a way that they are no longer able to be handled by the solver. The Cut-Off elements are therefore decomposed into homogenous prism and tetrahedral elements following the Cut-Off operation. An example of such a decomposition is shown in the figure below. The decomposition takes place automatically during Solid Model generation.

Figure 2.146: A Degenerated Hexahedral Element (left) is Decomposed into Several Tetrahedral Elements (right)

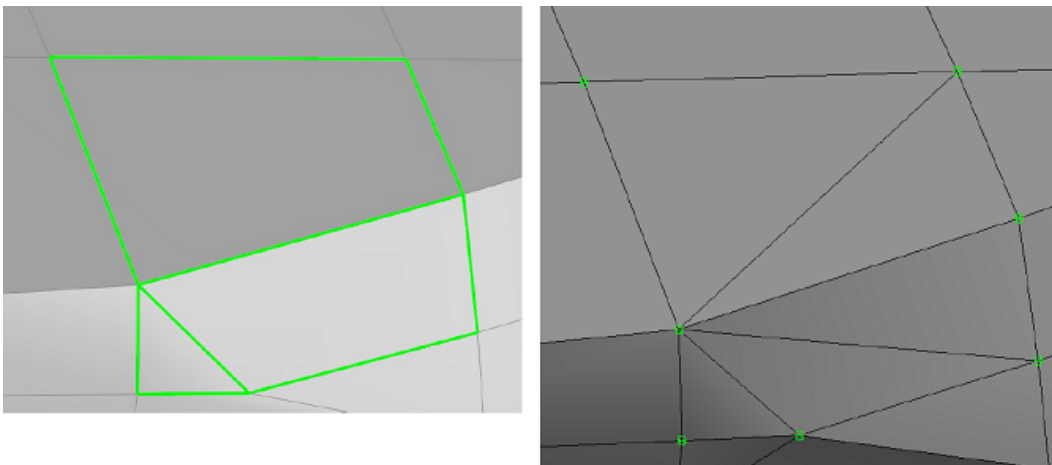

2.1.16.1.5.3. Limitations

The Cut-Off Geometry feature modifies elements by cutting off nodes. However, it does *not* refine the local mesh to conform precisely to the Cut-Off Geometry.

The sketch below illustrates how the Cut-Off Geometry Feature works: A node (a) of the finite element is within the Cut-Off Geometry, so it is removed from the element. But no additional nodes are added where the element edges intersect with the Cut-Off Geometry. Instead, the element is converted into a degenerated shape (B), in this case from a quad to a triangle. This also happens for 3D elements (prisms and hexes).

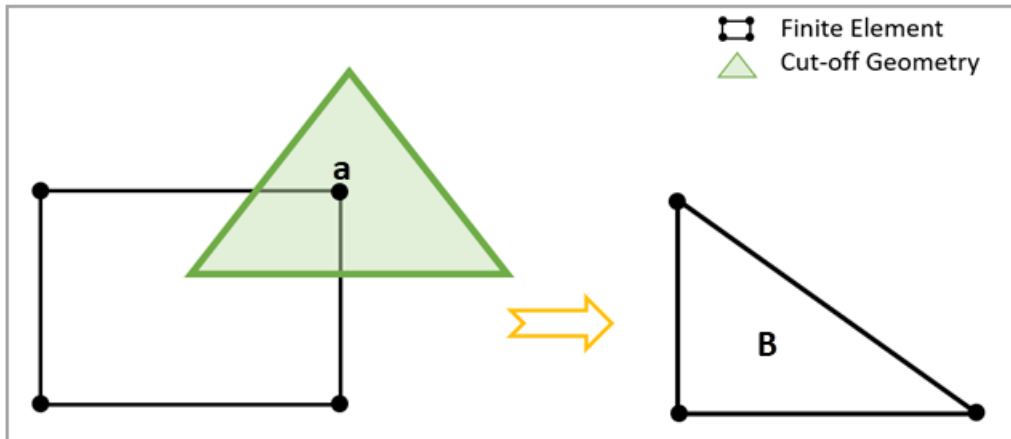

In many cases, the resulting element mesh will not represent all the features of the Cut-Off Geometry. This is especially true when the Cut-Off Geometry has sharp edges or features that are below the resolution of the elements. In the sketch shown below, for example, the finite element retains its shape because none of its nodes fall within the Cut-Off Geometry. To remedy this, you must refine the solid mesh by modifying the original shell mesh.

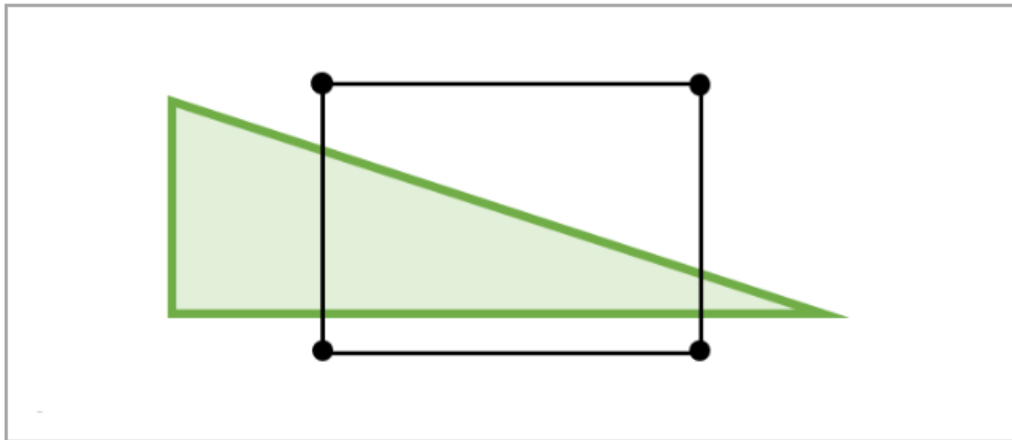

Another limitation is that degenerated elements (tetra elements, for example) do not support layered section data. Instead, the cut-off material, which is defined either in the **Solid Model Properties** (p. 185) or in the **Fabric Properties** (p. 86), is assigned to the element. You can manage this by using the Analysis Ply-Wise Extrusion Method. Ansys recommends that you assess the results of cut-off elements carefully.

2.1.16.1.6. Mesh Components

This folder contains Element Sets which were generated during the extrusion. For instance, the **DropOffset** contains all Drop-Off elements. This is the area where the thickness of the solid elements drops to zero, and homogeneous elements are generated at the boundary.

You can select and highlight the mesh components in the Scene if the Element Selection Mode is set to Automatic or Solid (see **Mesh Appearance** (p. 26)).

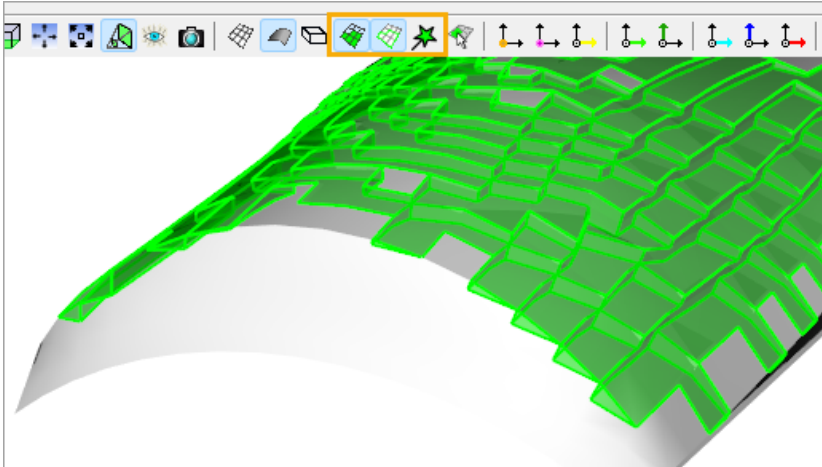
Figure 2.147: Solid Model with Highlighted Drop-Off elements

2.1.16.1.7. Material Handling for Different Extrusion Methods

The material handling for an analysis ply-wise extrusion follows the rules outlined in [Fabric Solid Model Options](#) (p. 86). The following additional rules apply for other extrusion methods where plies of different materials are grouped together in one solid element layer.

Drop-Off Material Handling in Non-Analysis-Ply-Wise Extrusions

- If the material handling option of at least one ply is set to **Global**, the global Solid Model Drop-Off material is used.
- If all ply material handling options are set to **Custom** and refer to the same custom material, the custom Drop-Off material is used.
- In all other cases (for example, a multi-layered solid with material handling options **Custom** and **Global**), the global Solid Model Drop-Off material is used.

Cut-Off Material Handling in Non-Analysis-Ply-Wise Extrusions

- If the material handling option of at least one ply is set to **Global**, the global Solid Model Cut-Off material is used.
- If all ply material handling options are set to **Custom** and refer to the same custom material, the custom Cut-Off material is used.
- In all other cases, the global Solid Model Cut-Off material is used.

2.1.16.1.8. Save & Reload Solid Models

ACP Solid Models are saved as `.H5` files. An update of **ACP (Pre)** component initiates a check of the current and previous laminate lay-up. While the laminate lay-up does not change no new solid model is generated.

2.1.16.1.9. Node-based Thicknesses

By default, the solid model extrusion and the 3D lay-up representation used for the lay-up mapping within the Imported Solid Model are based on the ply thicknesses at the element center. If the

Use Nodal Thickness is on (see [Lay-up Computation \(p. 65\)](#)), the solid model extrusion and 3D lay-up representation directly consume the node-based thicknesses, which can improve the accuracy. For more information, see the [Element- vs. Node-based Thicknesses \(p. 68\)](#) section.

2.1.16.2. Imported Solid Model

Topics in this section:

[2.1.16.2.1. Imported Solid Model Properties](#)

[2.1.16.2.2. Mesh Components](#)

[2.1.16.2.3. Lay-up Mapping Objects](#)

[2.1.16.2.4. Quality Check](#)

[2.1.16.2.5. Miscellaneous](#)

The Imported Solid Model feature enables you to map the Composite Definitions of ACP (Pre) onto the mesh of an external (imported) solid model. This approach can be used if the standard solid model approach, that is based on an extrusion algorithm and post operations, fails or produces a mesh of poor quality. In that case, it is more robust to mesh the final composite solid structure first, independent of the lay-up data and, in a second step, to map the Composite Definitions. See the [Guide to Solid Modeling \(p. 283\)](#) section for solid model workflows as well as tips used when working with a solid model.

Figure 2.148: Tree Object of the Imported Solid Model Feature

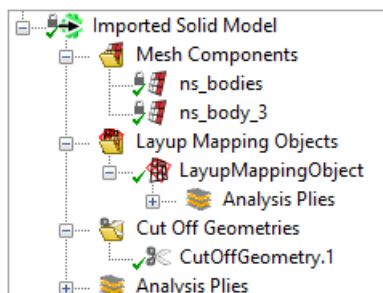

The Imported Solid Model (containing lay-up mapping data) can be used in combination with structured elements (such as brick, prism, or wedge) and degenerated shapes (tetra and pyramid). The Lay-Up Mapping Objects feature provides several options to control the mapping. For more information on the element technologies, material handling, and element orientations, see [Lay-up Mapping Objects \(p. 212\)](#). The imported solid mesh with the mapped lay-up data is exported for downstream analyses using the standard solid model workflow in Workbench.

The lay-up mapping feature is the 3D representation of the lay-up model computed immediately after the imported solid model updates. This 3D representation always follows the surface normal of the shell mesh. The imported solid model does not support the [Extrusion Guides \(p. 195\)](#) feature. If you need to manage the free edges in curved areas, one recommended approach is to enlarge the shell surface and plies in the in-plane direction.

The elemental component sets that are defined in the external solid mesh are listed in the **Mesh Components** sub-folder and are used to define the scoping of the [Lay-up Mapping Objects \(p. 212\)](#). All component sets (also node sets) of the initial solid mesh are passed as Named Selections to the downstream analyses (**Mechanical Model**) and can be used to maintain correct associations (such as boundary conditions or contacts).

See the [Analysis of a Mapped Composite Solid Model \(p. 326\)](#) section for an example analysis.

Cut-Off Geometries can be used to shape the Imported Solid Model in a desired way. They are specified in the respective subfolders in the Imported Solid Model Tree View. The Cut-Off feature behaves in the same way for the Imported Solid Model as it does for the standard Solid Model. It is described in [Cut-Off Geometry \(p. 202\)](#). The Analysis Plies sub-folder shows which Analysis Plies are incorporated in the lay-up mapping.

This Cut-Off feature allows you to shape the imported solid mesh after the lay-up mapping. It gives you further control of geometry and mesh. You can add details and geometrical features to the Imported Solid Model. Therefore, the generation of a structured mesh will be easier and more robust for many cases.

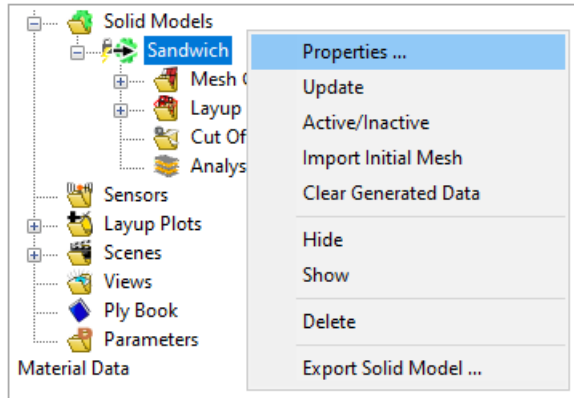

The context menu of the Imported Solid Model contains these actions:

- **Properties:** Opens the **Properties** dialog of the imported solid model.
- **Update:** Runs the lay-up mapping algorithm and updates all dependencies of the Imported Solid Model.
- **Active/Inactive:** Toggle whether the Imported Solid Model is suppressed or not.
- **Import Initial Mesh:** Loads the initial mesh of the solid model without performing the lay-up mapping.
- **Clear Generated Data:** Removes all elements and mapped lay-up data from the object.
- **Hide:** Hide the solid model in the Scene.
- **Show:** Show the solid model in the Scene.
- **Delete:** Delete the Imported Solid Model. Not possible if the object is locked.
- **Export Solid Model:** Export the mesh or skin of the solid model as a geometry or as a Mechanical APDL input file.

2.1.16.2.1. Imported Solid Model Properties

You can configure the settings for the Imported Solid Model under the Imported Solid Model context menu item **Properties**. The properties dialog covers some basic settings where the scope of the lay-up mapping is configured through the Lay-up Mapping Objects.

2.1.16.2.1.1. General Tab

2.1.16.2.1.2. Export Tab

2.1.16.2.1.3. Mapping Statistics

2.1.16.2.1.1. General Tab

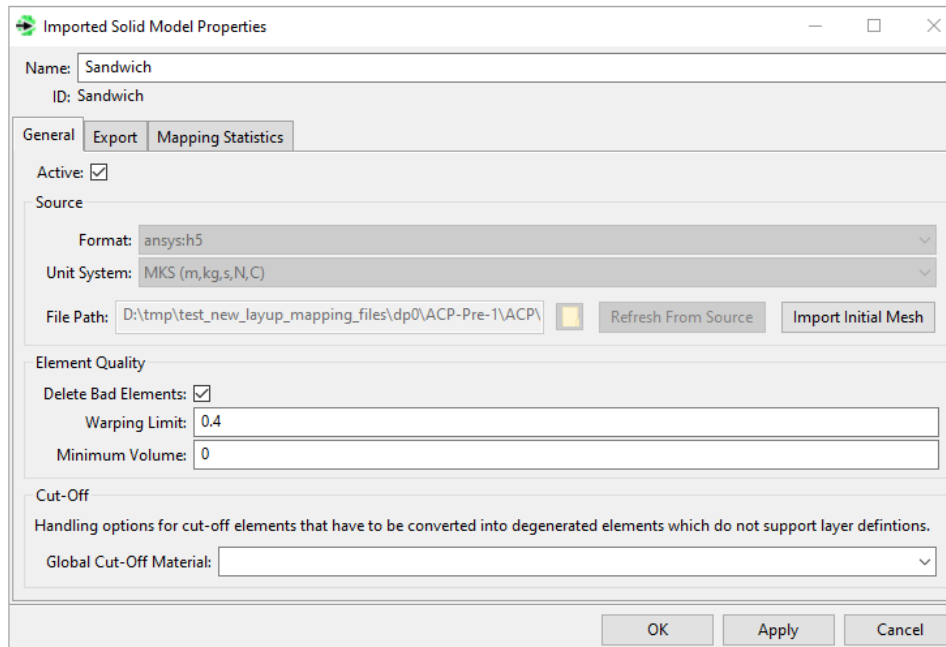

- **Name:** Name of the object
- **Format:** This property specifies the format of the input file. Within a Workbench project, solid meshes are imported via a **Mechanical Model** (p. 48) component. The import automatically completes the Format, Unit System, and File Path properties, so as a result, these properties are read-only.

If you are running ACP in standalone, you can directly import Ansys CDB files in ACP Pre. For this scenario, you need to specify the Unit System of the volume mesh.
- **Unit System:** This property specifies the unit system of the external solid mesh which is used to automatically convert the solid mesh into the unit system of ACP.
- **File Path:** Specifies the location of the mesh file to be imported.
- **Refresh From Source:** Only enabled in ACP standalone. Click to prompt ACP to reread the mesh from the source file. Use this feature whenever the source file is modified because ACP does not re-read the data automatically.
- **Import Initial Mesh:** Loads the initial mesh of the solid model into the ACP Model without performing the lay-up mapping. This can be used, for example, after using the **Clear Generated Data** feature, to show the initial mesh once again.
- **Element Quality (Delete Bad Elements, Warping Limit, Minimum Volume):** See the explanation for **Element Quality** under *Solid Model Properties* (p. 188).

- **Global Cut-Off Material:** Controls the global material handling for Cut-Off Elements in the solid model. Cut-Off Elements which have a degenerated shape (tetra) do not support layers and therefore are filled with a Cut-Off material. This setting is used when the material handling settings for fabrics and stackups are set to **Global**. See [Fabric Solid Model Options](#) (p. 86).

2.1.16.2.1.2. Export Tab

The export tab options are a limited set of the standard solid model options. See [Export](#) (p. 191) in the *Solid Model Properties* section.

2.1.16.2.1.3. Mapping Statistics

The **Mapping Statistics** tab includes basic results regarding the lay-up mapping such as total mass, volume, resin volume content, and so on. The **Ply-Wise Data** table shows the volume per analysis ply and the difference compared to the lay-up definition based on the shell mesh. The solid mesh ply volume is greater if the difference is positive, smaller if negative.

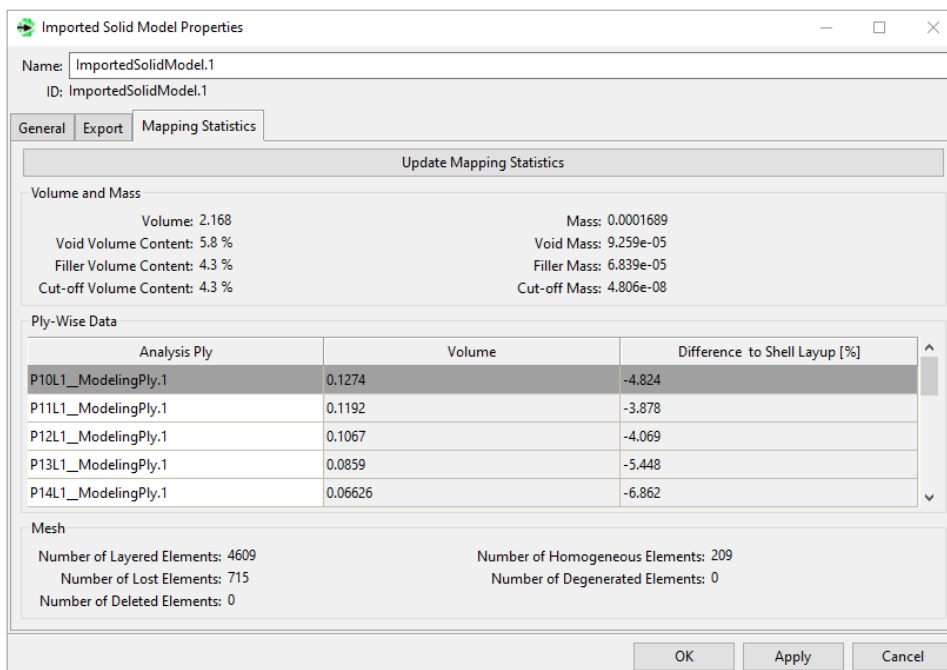

2.1.16.2.2. Mesh Components

Mesh Components (Element Sets) in the external solid mesh are listed in this folder. Mesh Components are either:

- Named Selections in Mechanical
- Component sets in Mechanical APDL
- Or components of elements in the external mesh generated by a third-party meshing application

Note that Mesh Components cannot be visualized in the Scene until the initial mesh is loaded. This happens when you **Import Initial Mesh** or **Update** the Imported Solid Model. Mesh Components cannot be edited nor copied, and they are read-only.

Figure 2.149: Transfer of Mesh Components from an External Mesh via External Model, Mechanical to ACP Pre

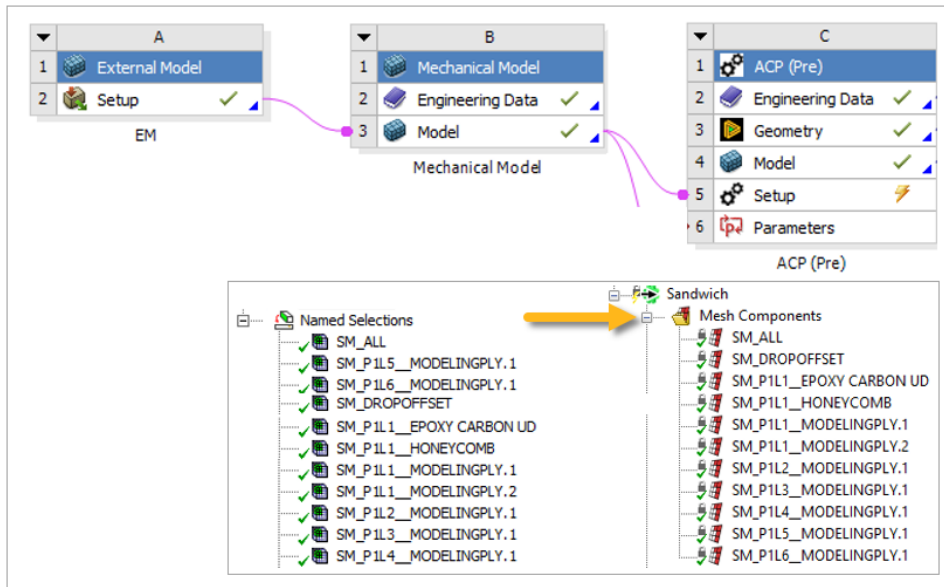

2.1.16.2.3. Lay-up Mapping Objects

This folder contains the Lay-up Mapping Objects used to define mapping scopes and to configure material handling. An Imported Solid Model can have multiple Lay-up Mapping Objects defining which plies are mapped to which components of the solid mesh. Note that the node connectivity remains unchanged, regardless of the number of Lay-up Mapping Objects.

The Analysis Plies folder under a Lay-up Mapping Object lists all the [imported \(p. 164\)](#) and/or simple [Analysis Plies \(p. 156\)](#) of the source scope. The list becomes available after updating the object and helps to verify the source scope.

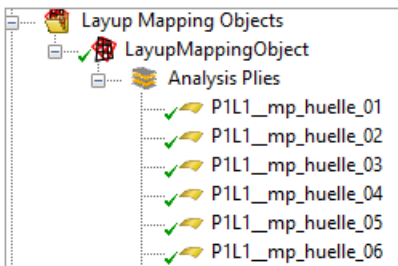

The properties of the Lay-up Mapping Object are split into **General**, **Layered Elements**, and **Reinforcing**.

2.1.16.2.3.1. General Tab

2.1.16.2.3.2. Layered Element Tab

2.1.16.2.3.3. Reinforcing Tab

2.1.16.2.3.1. General Tab

The **General** tab configures the source and target scopes of the lay-up mapping. The source scope is defined by a set of shell elements and a list of plies. The mesh components of the

solid mesh define the target scope. This enables a component-wise mapping of the lay-up model onto the solid mesh.

The **Element technology** for Imported Solid Models is the lay-up mapping feature that supports layered and reinforcing elements. You can configure it in the **General** tab or the respective option's tab. The following contains more information on the two **Element technology** options:

Layered Elements

- The layered element technology should only be used if the solid mesh consists mainly of brick or prism elements, which are then treated as layered ones. These elements are automatically aligned according to the normal direction of the lay-up and are filled with layers.

Note:

If the layered element faces are not parallel to the lay-up direction, there might be inaccuracy since its normal direction would differ from the lay-up direction.

- Degenerated elements (pyramid, tetra, etc.) are filled with the filler material and become homogeneous elements, as well, because they do not support layered data. The element coordinate system of homogeneous elements can be defined by one or several [rosettes \(p. 103\)](#).
- Elements that do not intersect with the mapped lay-up can be deleted or filled with a filler material. In that case, they are handled as homogeneous elements.

Reinforcing Elements

- The reinforcing element technology adds material to an existing element by intersecting the element with basic shapes (link, shell, etc.). For more information, see [Reinforcing Elements in the *Element Reference*](#). This technology uses the [REINF265](#) element which enables adding material to a 3D solid element. Therefore, it can be used with any solid mesh type. The solid elements are always homogenous, and their coordinate system is also defined by [rosettes \(p. 103\)](#). Also, the reinforcing plies and their material direction are independent of the base element.

The **Source Scope** is defined by a set of shell elements and a list of plies, while the **Target Scope** is defined by the mesh components of the solid mesh. This enables a component-wise mapping of the lay-up model onto the solid mesh.

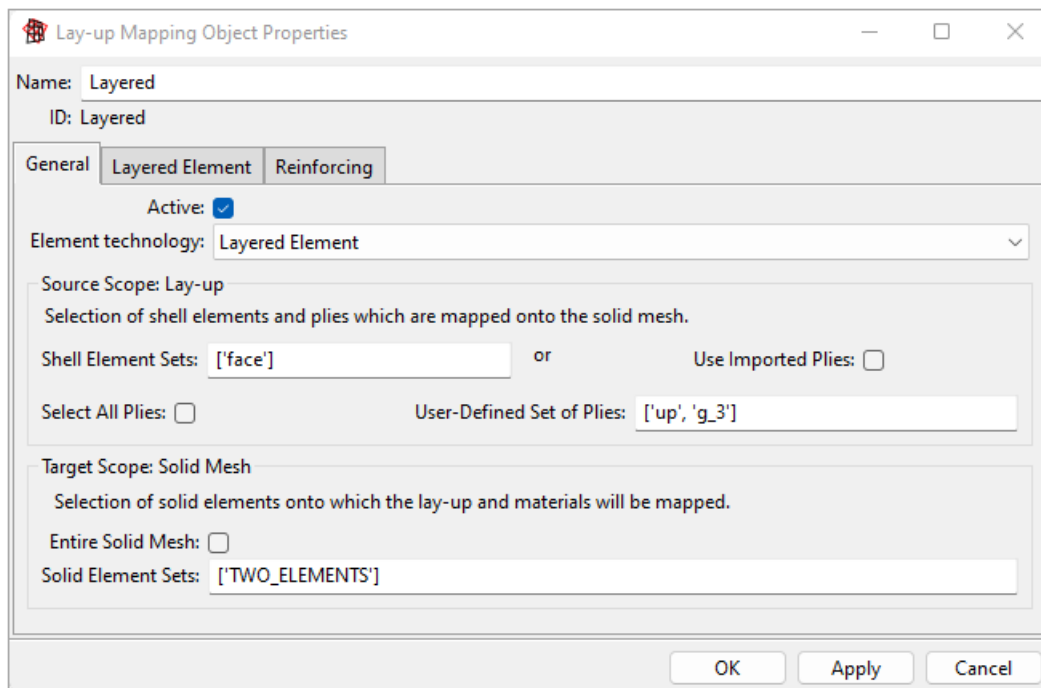

Source Scope: Lay-up

- **Shell Element Sets:** Select one or several Element Set(s) to define the region of interest. Starting with a shell model and the lay-up definition, the 3D representation of the laminate is generated for the selected region.

Note:

The **Middle Offset** (p. 95) option for Element Sets is not supported. The ply definition must be defined without this option to obtain an accurate mapping.

- **Use Imported Plies:** If enabled, Imported Plies are mapped onto the solid mesh instead of the standard Modeling Plies. In this situation, the **Shell Element Sets** option becomes irrelevant.
- **Select All Plies:** By default, this property maps all plies of the selected shell mesh (Shell Element Sets) onto the solid mesh. Clear this box to select a user-defined set of plies for the mapping. Modeling Groups and/or Modeling Plies can be selected.

If **Use Imported Plies** and **Select All Plies** are *both* enabled, all Imported Plies are selected.

- **User Defined Set:** This field allows you to specify a set of Modeling Plies and/or Modeling Groups when selecting the plies to be mapped onto the solid mesh. The equivalent object types can be selected if **Use Imported Plies** is enabled.

Target Scope: Solid Mesh

- **Entire Solid Mesh:** If selected, the source scope (lay-up) and materials are applied to the entire solid mesh. This also means that no other Lay-up Mapping Object can be configured because the Target Scope cannot overlap.

- **Solid Element Sets:** Use this field to select the specific Mesh Components of the solid mesh to which the Lay-up Mapping Object will be applied. Mesh Components are Named Selections or Element Sets which are defined in the initial (external) solid mesh.

2.1.16.2.3.2. Layered Element Tab

In most cases, the lay-up does not fill the entire selected target scope (solid elements), or there are voids (gaps between layers). Use the options in the **Layered Element** tab to configure how voids are handled as well as the lost elements which do not intersect with the lay-up. Because these layered elements are defined per Lay-up Mapping Object, an Imported Solid Model can have multiple void and filler materials.

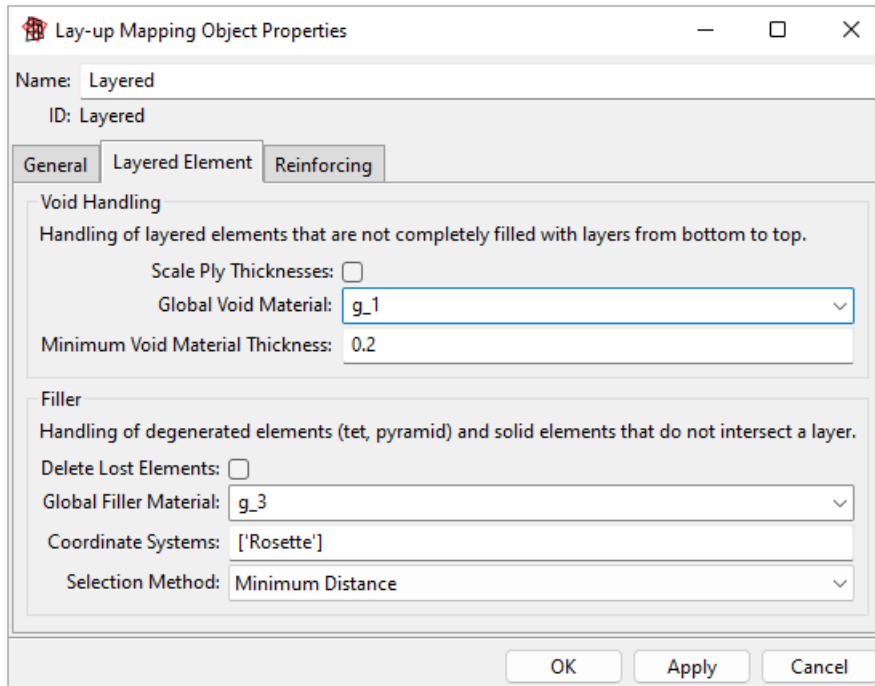

Void Handling

- **Scale Ply Thicknesses:** The thickness of the mapped lay-up and the geometrical thickness of layered elements can differ for various reasons (drop-offs, numerical differences, and so on). If this option is enabled, the thickness of the mapped laminate will be scaled to match the element as shown below. Note that the scaling is done per element and not on a global scope. Below is a side view of a layered solid with void space (A) and the same element after the ply thickness has been scaled (B).

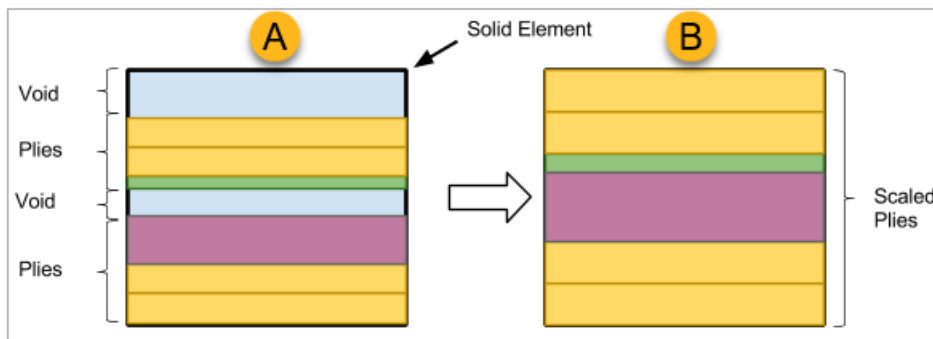

- **Global Void Material:** Instead of scaling the laminate, you can fill the void space with a specific material. To do so, be sure to *clear* the option **Scale Plies** and then define a void material. Use an isotropic material since the in-plane orientation cannot be defined.

Note that you can access elements with void material through the analysis ply **void_<material id>** within the **Analysis Plies** folder of the Imported Solid Model. There are as many void layers in the folder as the maximum number of void layers in a layered element. For instance, in the illustration below, there are two void spaces in a layered solid element.

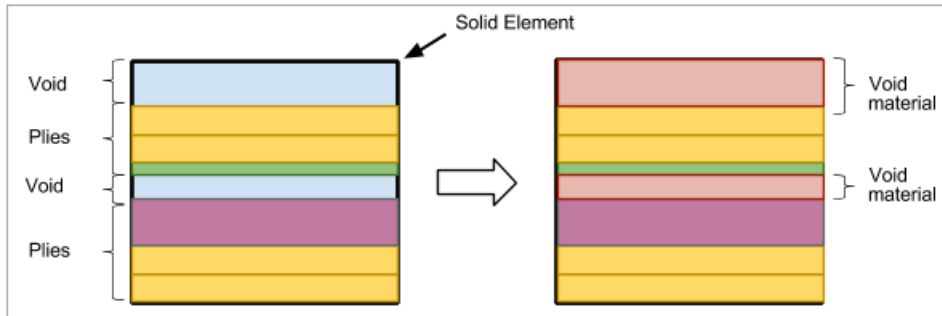

- **Minimum Void Material Thickness:** Void spaces, like those shown above, can be caused by drop-offs or differences between the shell and solid mesh, especially in curved areas— to name some examples. You can further refine the void handling by specifying the **Minimum Void Material Thickness**. If the thickness of the void space is less than the specified value, the void will not be filled. Instead, the regular plies are scaled to fill the void space.

In the illustration below, scaled layers and filled void space are both applied.

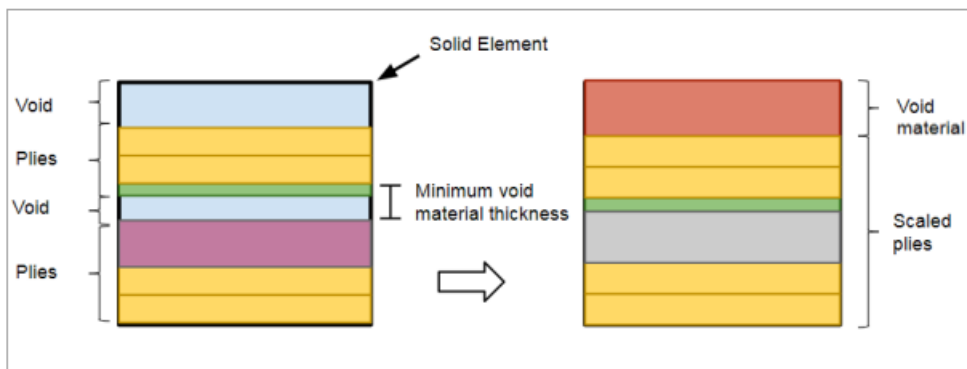

This raises a possible point of confusion: Why does ACP scale the plies if the option **Scale Plies** has been disabled? The fact is, the solver automatically scales the laminate whenever the total laminate thickness does not correspond with the element height, so ACP is performing the scaling already. The **Minimum Void Material Thickness** feature allows you to visualize and express numerically this effect in ACP.

Filler

Elements which do not intersect with the lay-up are called lost elements. They are either deleted or filled and oriented with a Filler Material and Rosette(s), respectively.

- **Delete Lost Elements:** Use this option to control whether solid elements without mapped lay-up data are removed or retained. Note that unstructured elements such as tets or pyramids are ignored in the mapping algorithm and are always treated as lost elements (elements without data).

- **Global Filler Material:** If the property **Delete Lost Elements** is disabled, a filler material must be assigned to the solid elements that do not have mapped lay-up data. Lost elements are handled as non-layered (homogeneous) elements. The characteristic of the filler material can be isotropic or anisotropic.

Note:

The homogeneous elements with filler material can be accessed through the analysis **ply filler_<material id>** within the **Analysis Plies** folder of the Imported Solid Model.

Orientation: Select one or several [Rosettes](#) (p. 103) to orient the filled elements. Note that the Rosettes are used to evaluate the fiber directions (local x-axis) and the normal directions (local z-axis) of the elements. This is slightly different compared to [Oriented Selection Sets](#) (p. 132) where the Rosettes are used to apply the reference directions only.

If the Normals and Fiber Directions plot is enabled, you can visualize the element's x and z axes by selecting the filler layer.

Figure 2.150: Element Normals of the Filler Elements Computed from Two Rosettes.

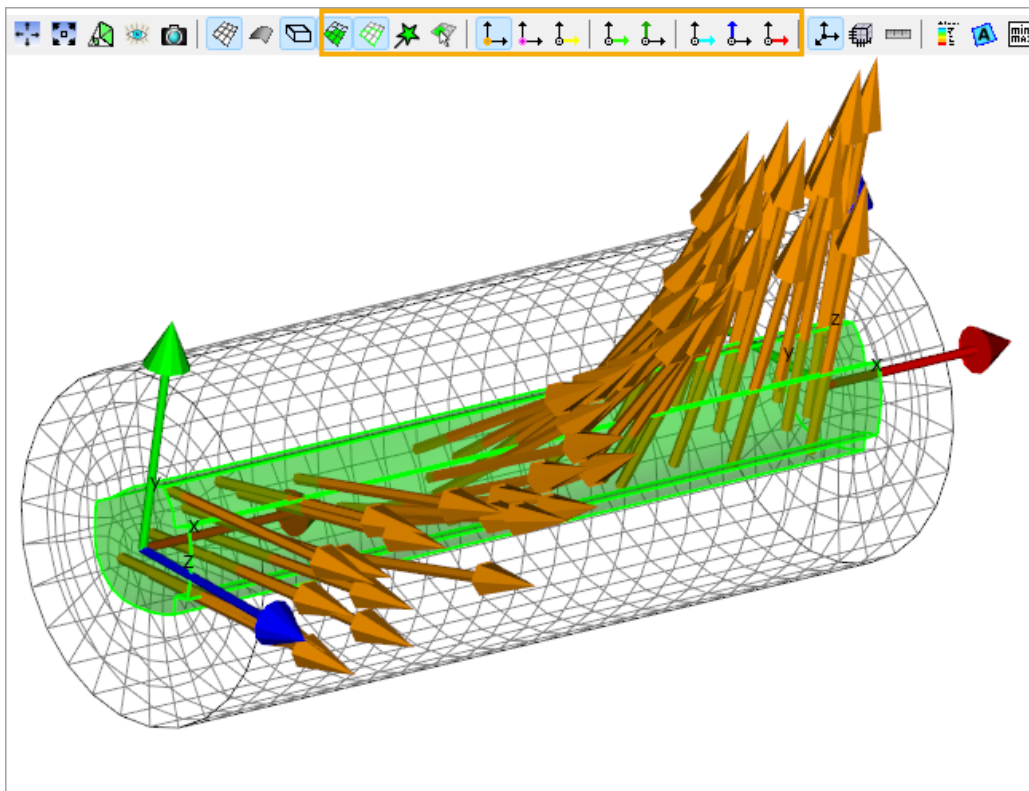

- **Selection Method:** Supported options include **Minimum Distance** and **Minimum Distance Superposed** as described in [Oriented Selection Set](#) (p. 132).

Use Filler Option Only: The Lay-Up Mapping Object also allows you to fill **Mesh Components** or the entire solid mesh with a filler material and to orient the elements so that no plies from the lay-up are mapped. To do so, define an empty Source Scope in the **General** tab (A, below).

In the **Materials** tab (B), clear the **Delete Lost Elements** option, and select a **Filler Material** and **Rosettes**.

The image shows a software interface with two main panels. Panel A, titled 'Source Scope: Lay-up', contains a description 'Selection of shell elements and plies which are mapped onto the solid mesh.' and several input fields: 'Shell Element Sets: []', 'Use Imported Plies: ', 'Select All Plies: ', and 'User Defined Set of Plies: []'. Panel B, titled 'Filler', contains a description 'Handling options for degenerated elements (tet, pyramid) and solid elements that do not intersect a layer.' and several options: 'Delete Lost Elements: ', 'Global Filler Material: Filler 1', 'Orientation: ['Rosette', 'Rosette.1']', and 'Selection Method: Minimum Distance Superposed'.

The mapping algorithm, based on the 3D representation of the lay-up, consists of three main steps:

1. Aligns the structured solid elements according to the local offset direction of the 3D representation.
2. Evaluates the ply-wise intersections between the solid elements and plies. The mapping algorithm also detects if an element is completely within a ply. The output contains the element-wise plies' materials, thicknesses, and orientations. Thus, the element-wise section data.
3. Stores the data for downstream analyses.

Note:

The mapping algorithm evaluates the intersection at the center of the solid elements, therefore, the ply thicknesses are constant for the whole element.

2.1.16.2.3.2.1. Limitations

The following limitations are specific to the layered element technology:

- The projection of the failure results to the reference surface is not supported. Either do ply-wise analyses or use the Section Cut feature in Mechanical to investigate results inside the solid.
- Laminate failure criteria such as Wrinkling and Shear Crimping are not supported since the reconstruction of the stacking sequence of the laminate is not possible for mapped lay-up data.
- The mapping algorithm assumes that an analysis ply intersects only once with a solid element. Therefore, the scenario on the left side of the image is not supported, and the generated data is incorrect. A workaround is to split the ply as shown on the right side.

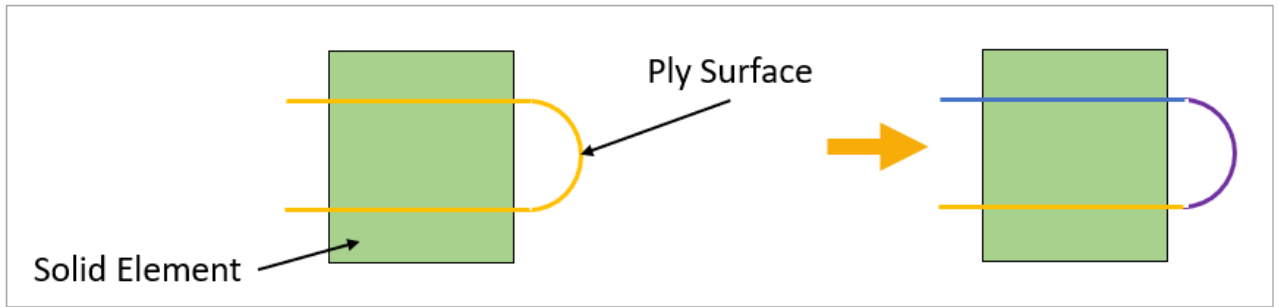

2.1.16.2.3.3. Reinforcing Tab

This tab becomes active when the **Element technology** is set to **reinforcing**. It enables the control of reinforcing elements' section properties and the configuration of the 3D solid elements' material and orientation.

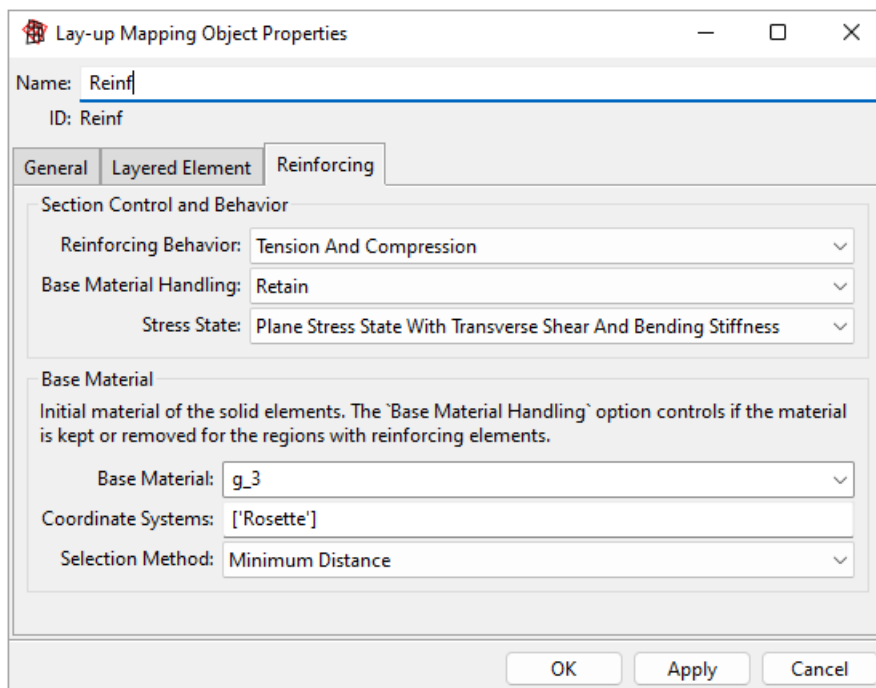

Use the following options to configure the reinforcing elements' structural behavior. For more information, see **SECCONTROL**:

- **Reinforcing Behavior:** Specifies whether the reinforcing elements carry tension and compression load, or only one of them.
- **Base Material Handling:** Removes the base material from the solid element where it intersects with the reinforcing elements or, otherwise, retains the base material. It is recommended to select **remove** if a high-volume fraction of reinforcing elements is expected.
- **Stress State:** Specifies if the reinforcing elements should behave like a link, membrane, or shell element (with or without bending). For more information, refer to **SECCONTROL–Type: REINF**.

Reinforcing elements use the stiffness of the plies for the solid elements. An initial material must be assigned to the solid elements because it is possible that some elements are not reinforced. The following options enable the specification of the initial material and orientation (if the material is orthotropic):

- **Base Material:** Specifies the solid elements' material before the reinforcing elements are applied. The base material characteristic can be either isotropic or anisotropic.
- **Orientation:** Selects one or more rosettes to orient the solid elements. Here, rosettes are used to evaluate the material 1 directions (local x-axis) and normal directions (local z-axis) of the elements. These characteristics are different from [Oriented Selection Sets \(OSS\)](#) (p. 132), where the rosettes are only used to apply the reference direction.
- **Selection Method:** Supported options are **Minimum Distance** and **Minimum Distance Superposed** as described in [Oriented Selection Sets \(OSS\)](#) (p. 132).

2.1.16.2.3.3.1. Design Tips and Best Practices

Mesh Quality

You can use the reinforcing technology with all solid element types (brick, prism, pyramid, or tetra). Nevertheless, their shape must be of good quality, and not too distorted, so the reinforcing elements can successfully apply to the base elements.

Element Size vs Ply Thickness

You can independently define the reinforcing elements of the base elements, including their size, shape, and element formation. It is essential that the plies' thickness is smaller than the base elements' size. This ensures that the reinforcing elements' stiffness accurately applies to the base elements. For instance, you can model thick plies, such as core materials, with multiple thin plies instead of one thick ply. For more information, see **Number of Layers** in [Modeling Ply Properties](#) (p. 142).

Cut-Off Geometry

You can use the [Cut-Off Geometry](#) (p. 202) feature with the reinforcing elements. The algorithm might result in solid elements with reduced shape quality and cause issues when combining the reinforcing elements with the base elements. Therefore, you should mesh the final geometry instead of shaping the solid mesh in ACP with cut-off geometries.

2.1.16.2.3.3.2. Limitations

The following limitations are specific to the reinforcing element technology:

- The standard composite post-processing features (failure tool, ply-wise result visualization, etc.) are not supported for reinforcing elements. Use Mechanical APDL for post-processing your analysis.
- The [composite workflows](#) (p. 39) in Workbench does not support reinforcing elements and will skip all of their instances. The complete solid model with reinforcing elements can be exported to Mechanical APDL via **Export Solid Model** from the context menu of the Imported Solid Model.

- The analysis ply thickness should be smaller than the solid elements' height. Otherwise, the contribution of the reinforcing elements to the element stiffness might be incorrect. For more information, see [Design Tips and Best Practices \(p. 220\)](#).

2.1.16.2.4. Quality Check

The application offers several options to verify the quality of the mapped lay-up.

- You can examine the fiber directions and element normals using the Orientation Visualizations options on the Toolbar.

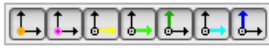

Make sure that the solid elements are highlighted by having these mesh appearance settings:

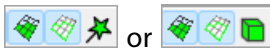

- You can use the [Thickness Plot \(p. 222\)](#) to display the ply-wise thicknesses on the solid elements. You can also select the Component option **Relative Thickness Correction** to plot the ply-wise scaling factors.
- [lay-up Mapping Plot \(p. 222\)](#) enables you to plot ply-wise volume contents and the deviation of the normal direction between the shell mesh and solid mesh. This plot works only if the **Element technology** is set to layered elements.
- You can get a general overview using the mapping statistics if the **Element technology** is set to layered elements.
- **Reinforcing Elements:** A model that can also be reviewed in Mechanical APDL. These Mechanical APDL commands show the reinforcing elements together with the reinforced solid elements.

```
alls
esel,u,ename,,REINF265
/trlcy,elem,0.9
esel,all
! Enable the expanded element shapes.
/eshape,0.05
eplot
```

The following commands are used to plot the main material (reinforcing) direction.

```
/dev,vect,1
! Select only reinforcing elements (optional)
esel,s,ename,,REINF265
/psymb,layr,-1
eplot
```

2.1.16.2.5. Miscellaneous

The global model property 'minimum analysis ply thickness' also counts for the lay-up mapping. A layer is only added to an element if the mapped layer thickness is greater than this value.

The lay-up representation (shell) is ignorant to the concept of Drop-Off elements (solid) and this can lead to 'voids' if you have steps in the lay-up as shown in the figure below. If the drops are low, this can be neglected, if they are high you might have to refine the tapering or adjust the void handling of the imported solid model.



In general, the mapping is mesh independent and the shell and solid mesh do not have to be coincident. However, too big of a difference in the meshes might cause inaccurate results. Therefore you should work with meshes with similar element sizes, especially in curved regions.

The shape functions of the shell and solid elements can differ. For instance a Composite Definition of a linear shell mesh can be mapped onto a quadratic solid mesh.

Full cross-sections: The mapping might not work as expected for plies that shrink into a very small tube as pictured below on the left hand side. In that case, it is more robust to have several plies of moderate thickness instead of one thick ply as shown by the right picture.

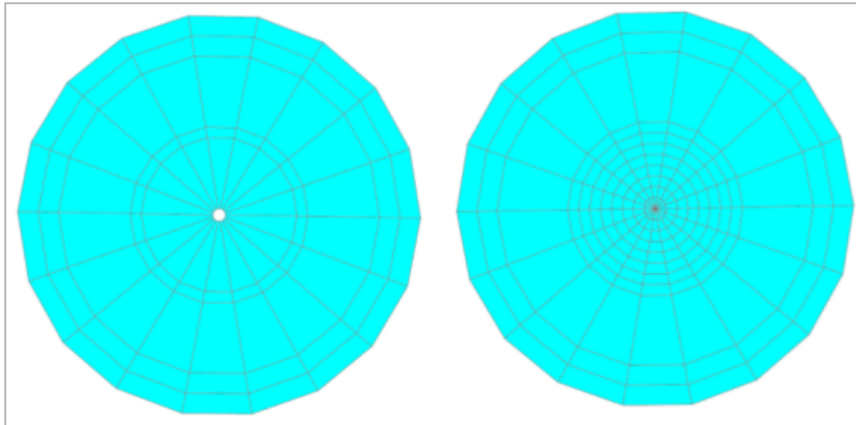

2.1.17. Lay-Up Plots

Lay-Up Plots enable you to verify and visualize element and ply-wise data, such as thickness and angle, of the Composite Definition in ACP (Pre). Available Lay-up Plots include:

- [Thickness Plot \(p. 226\)](#)
- [Ply Angle Plot \(p. 227\)](#)
- [Draping Mesh Plot \(p. 227\)](#)
- [Look-Up Table Plot \(p. 229\)](#)
- [Field Definition Plot \(p. 231\)](#)
- [Lay-Up Mapping \(p. 231\)](#)
- [Material Plots \(p. 233\)](#)
- [User-Defined Plot \(p. 233\)](#)

2.1.17.1. Interface Options

The right-click context menu for the Lay-Up Plots object provides the following options:

- **Create Thickness:** plot thicknesses per element or ply-wise
- **Create Lay-Up Angle:** plot ply-wise angles (fiber, shear angle etc.)
- **Create Draping Mesh and Flatwrap:** plot draping mesh and flatwrap
- **Create Scalar Look-up Table:** plot scalar look-up tables and interpolations
- **Create Field Definition:** plot field definition data
- **Create Lay-Up Mapping:** plot lay-up mapping data
- **Create User-Defined:** plot a custom set of data on the mesh
- **Paste:** paste a lay-up plot from the clipboard.

The context menu for each individual Lay-Up Plot option includes the following selections:

- **Properties:** Display the Plot Properties dialog.
- **Update:** Update the selected plot.
- **Copy:** Copy the selected plot definition to the clipboard.
- **Paste:** Paste a lay-up plot from the clipboard.
- **Delete:** Delete the selected plot.
- **Hide:** Hide the selected plot.
- **Show:** Show the selected plot.

All plots can display the information for all or a selection of elements through the data scope. A thickness and angle plot for all Element Sets is predefined by default. The plot definition for lay-up plots follows the same definition as solution plots.

The properties for plots, such as Thickness properties illustrated below, have two tabs: **General** and **Legend**. You can use the General tab to configure the plot's basic settings. Once you deselect the Use Default check box, the Legend tab enables you to specify minimum and maximum values as well as changing the legend title, range, and color display.

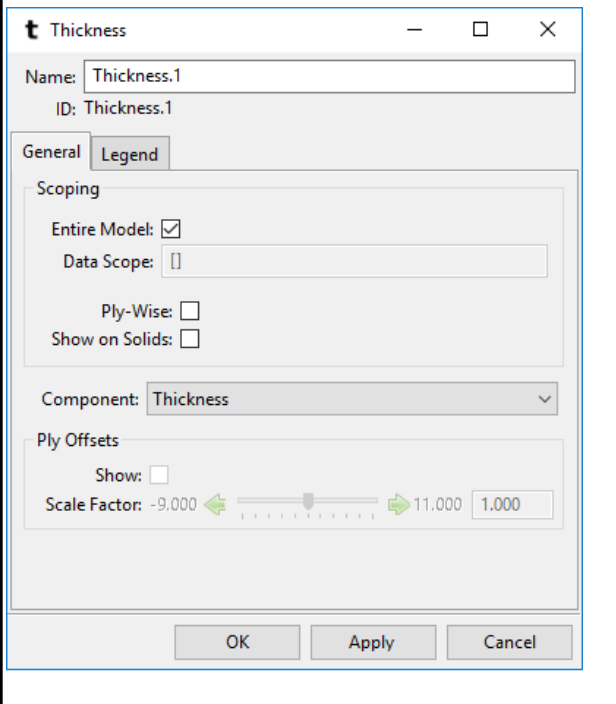
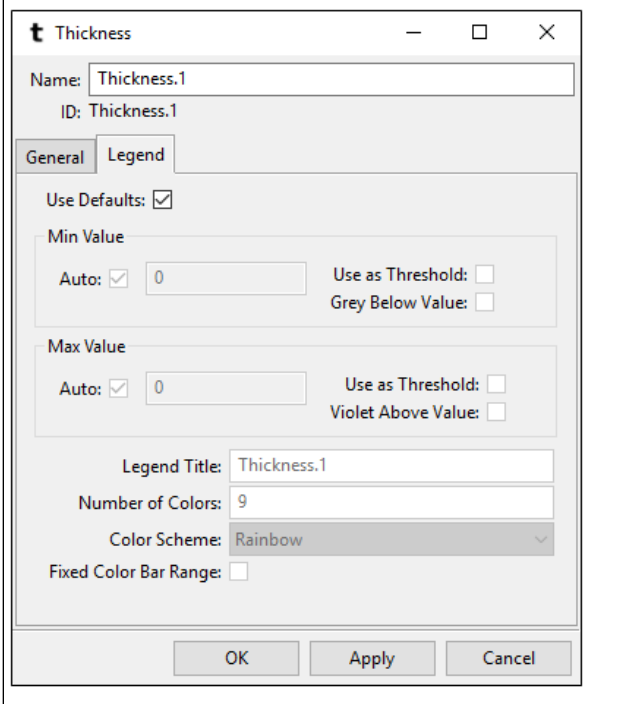
General Tab	Legend Tab
	
<p>The following general settings can be found in most of the plots:</p> <ul style="list-style-type: none"> • Name: Name of the plot. • Entire Model: If enabled, the scope of the plot is the entire shell- or all the solid elements of the model if Show on Solids is active. Otherwise you can define the scope through the Data Scope property. By default, Entire Model is enabled. • Data Scope: Determines what scope is used in the plot. Element sets, OSS, Modeling Plies & Sampling Points can be selected in the data scope. The data scope of a sampling point covers all plies that are intersected by the sampling point. • Ply-Wise: Activates a ply-wise plot display. Thickness and angle plot are only shown if a ply is selected. Angle plots are automatically set to ply-wise. The plies can be selected from the Modeling Groups, sampling points or solid model analysis plies. 	<p>Property descriptions include:</p> <ul style="list-style-type: none"> • Use Defaults: Uncheck this option to manually configure the color bar. Otherwise, the default settings are used. • Min Value: Defines the value of the first label. Disable Auto to set a user-defined value. • Max Value: Defines the value of the last label. Disable Auto to specify a user-defined value. • Use as Threshold: If enabled, the min and max labels become the second and second-to-last labels in the color bar, respectively. • Grey Below Value: Grey is inserted in the color bar. All values below the min label are then shown in grey. If Use as Threshold is on also, then the min label becomes the third label, and the second and first are evaluated accordingly. • Violet Above Value: Violet is appended to the color bar. All

General Tab	Legend Tab
<ul style="list-style-type: none"> • Show on Solids: Shows plot data on solid elements and for solid elements only. • Component: Allows you to select different components • Ply Offsets: Visualize the results of a ply-wise plot on the selected plies at their true or scaled offset from the reference surface (Angle Plot only). 	<p>values above the max label are then shown in violet. If Use as Threshold is checked as well, then the max label becomes the third-last label, and the second-last and last are evaluated accordingly.</p> <ul style="list-style-type: none"> • Legend Title: Specifies the title that is shown above the color bar. By default, the name of the plot is used. • Number of Colors: Sets the number of colors for the color bar. • Color Scheme: Chooses one of the preconfigured color schemes. • Fixed Color Bar Range: Activates the Fixed Color Bar Range option to prevent the color bar from changing when you switch from one ply to another. If enabled, the overall min and maximum values of the scope are set as color bar min and max labels. If ply-wise is enabled as well, the global min and max are used.

Note:

Only a subset of the plots support Imported Plies. Currently, these are Thickness Plot, Angle Plot and Lay-up Mapping Plot. To plot data on Imported Plies, the Entire Model and Ply-Wise options must be enabled.

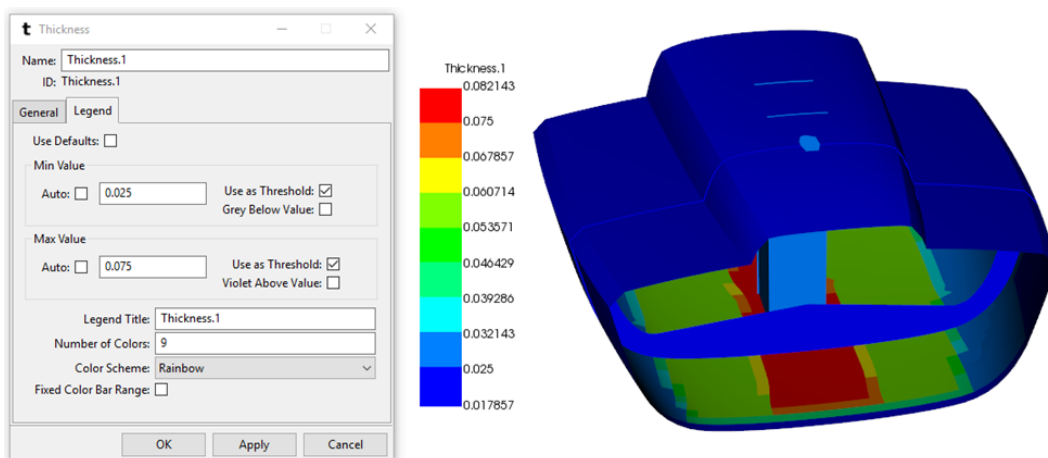

Thickness plot with "Use as Threshold" on for both the Min and Max Value.

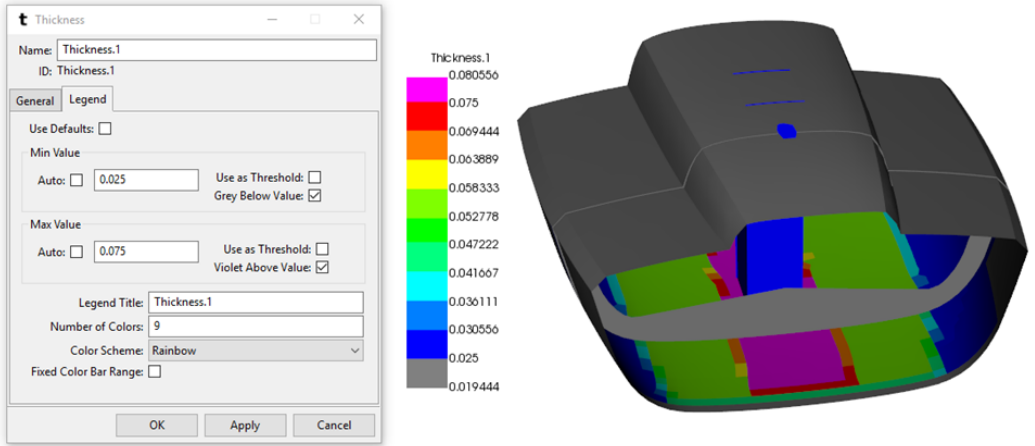

Thickness plot with "Grey Below Value" and "Violet Above Value" on.

2.1.17.2. Thickness Plots

The Thickness Plot shows the thickness distribution for an entire lay-up or single plies. The Angle Plot is purely a ply-wise plot and shows the orientation angle of a selected ply. The Look-Up Table Plot enables you to explore the interpolation result of scalar columns. Scalar columns can be used to define thickness, angle, or degradation fields.

Figure 2.151: Thickness Plot

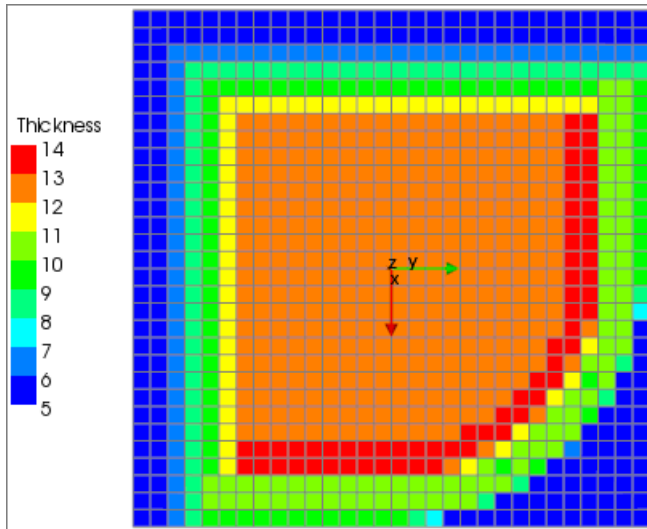

Components

The component of the plot include:

- **Thickness:** show the element thickness or ply-wise thickness
- **Relative Thickness Correction:** show the thickness scaling due to draping or lay-up mapping

2.1.17.3. Angle Plot

The Angle Plot is purely a ply-wise plot and shows the orientation angle of a selected ply. For example, an Angle Plot showing the shear angle of a draped ply is illustrated below.

Figure 2.152: Angle Plot

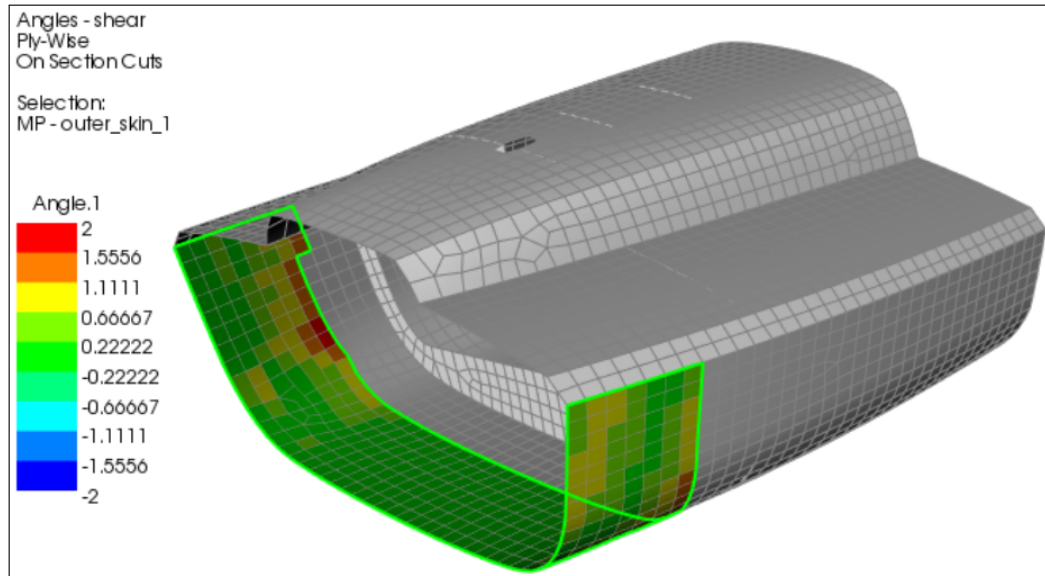

Components

The component of the plot include:

- **Design Angle:** The angle between the Reference Direction and the Fiber Direction. This is the angle between the element lay-up reference defined through the Oriented Selection Set and the user-set Ply Angle.
- **Draped Fiber Angle:** The angle between the Reference Direction and the Draped Fiber Direction. This is the angle between the lay-up reference defined through the Oriented Selection Set and the effective fiber direction due to draping.
- **Draped Shear Angle:** The local ply shear value due to draping.
- **Draped Transverse Fiber Angle:** The angle between the Reference Direction and the Draped Transverse Direction. This is the angle between the lay-up reference defined through the Oriented Selection Set and the effective transverse fiber direction due to draping.

2.1.17.4. Draping Mesh Plot

The Draping Mesh Plot enables you to control if the Draping Mesh or the Flatwrap of a draping simulation are shown in the active Scene. You need to select a Production or Analysis Ply in order to show the draping mesh and/or the flatwrap.

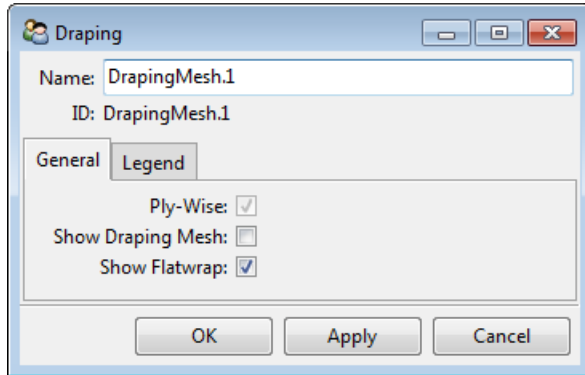
Figure 2.153: Draping Mesh Plot Properties

For this plot type, specific options of the **General** tab include:

- **Show Draping Mesh:** Shows the Draping Mesh Plot. The worst distortion is located in red areas of the draping mesh. If the model property [Use Draping Offset Correction \(p. 65\)](#) is active, the draping mesh is displayed at the bottom offset (relative to the reference surface orientation) of the selected ply.
- **Show Flatwrap:** Shows the Flatwrap surface that is a result of the draping in ACP.

The Draping Plot shows the average shear (distortion) angle of each element. The angles are given in degrees and they are the average absolute values of the corner angles differing from 90 degrees. Therefore, no distortion is equal to zero degrees. More information on draping can be found in the section [Composite Modeling Techniques under Draping \(p. 279\)](#).

The following illustrations show examples of Draping Mesh, Draping Plot for a Hemisphere, and Flatwrap Surface of the Ply.

Figure 2.154: Draping Mesh

Figure 2.155: Draping Plot for a Hemisphere**Figure 2.156: Flatwrap Surface of the Ply**

2.1.17.5. Look-Up Table Plot

The Look-Up Table Plot enables you to explore the interpolation result of scalar columns. Scalar columns can be used to define thickness, angle, or degradation fields for instance.

Figure 2.157: Look-Up Table Plot General Properties Tab

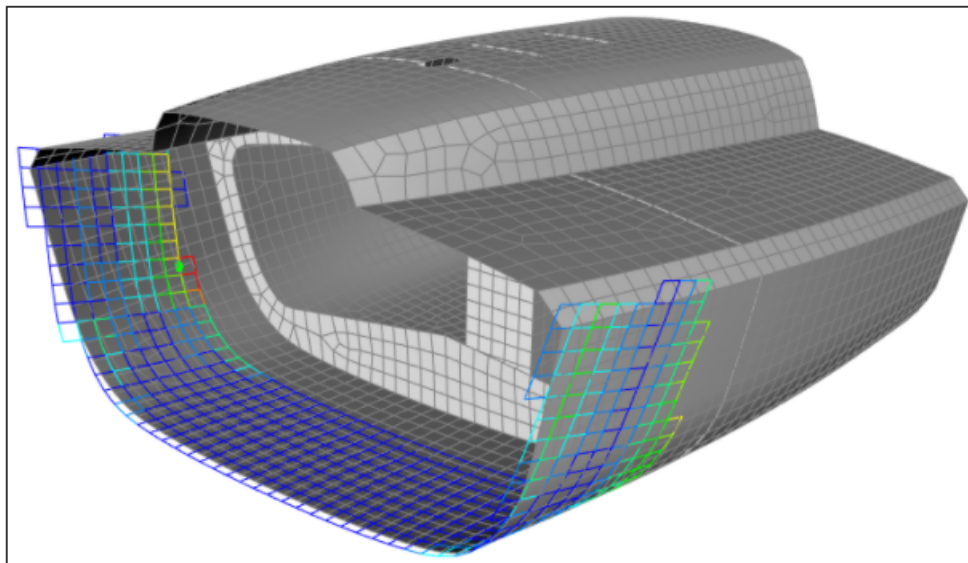
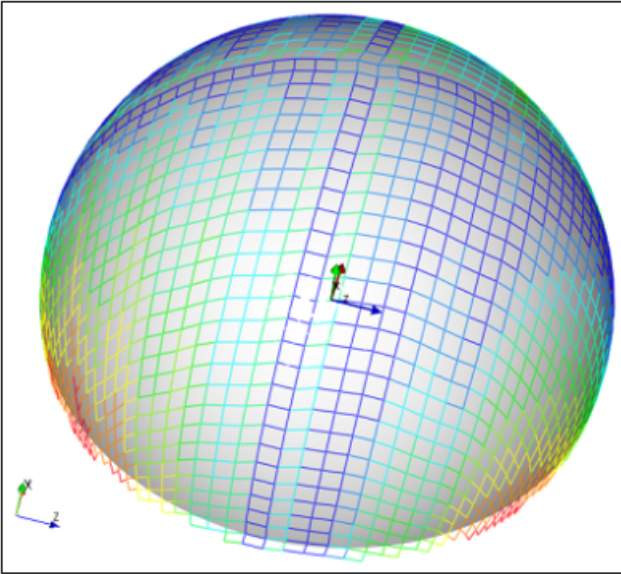
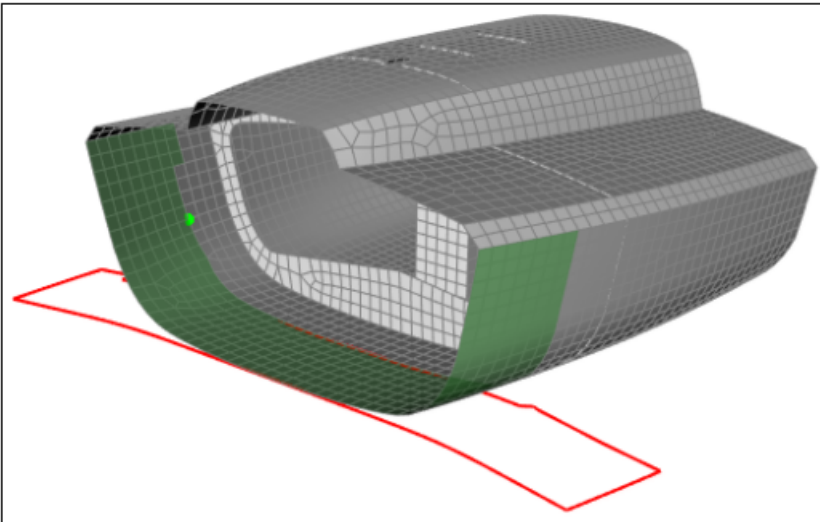
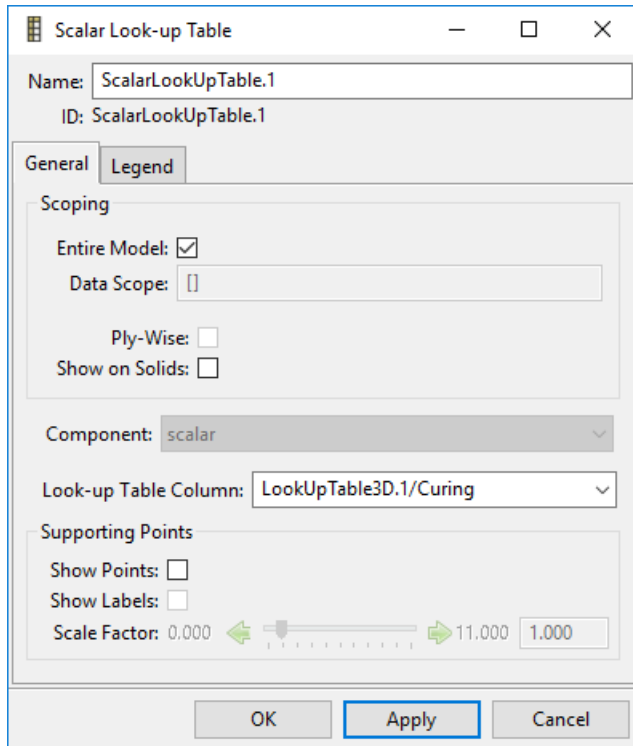
For this plot type, specific options of the **General** tab include:

- **Look-up Table Column:** Select the Look-up Table column data that is to be plotted.
- **Supporting Points:**
 - **Show Points:** Visualize the location of the supporting points of the plotted look-up table data.
 - **Show Labels:** Show labels indicating the row index in the respective look-up table.
 - **Scale Factor:** Scale the size of the supporting points.
- **Show Labels:** Show labels indicating the row index in the respective look-up table.
- **Scale Factor:** The supporting points can be scaled in size.

Figure 2.158: Look-Up Table Plot of a 1-D Scalar Quantity with Supporting Points Shown as Circles

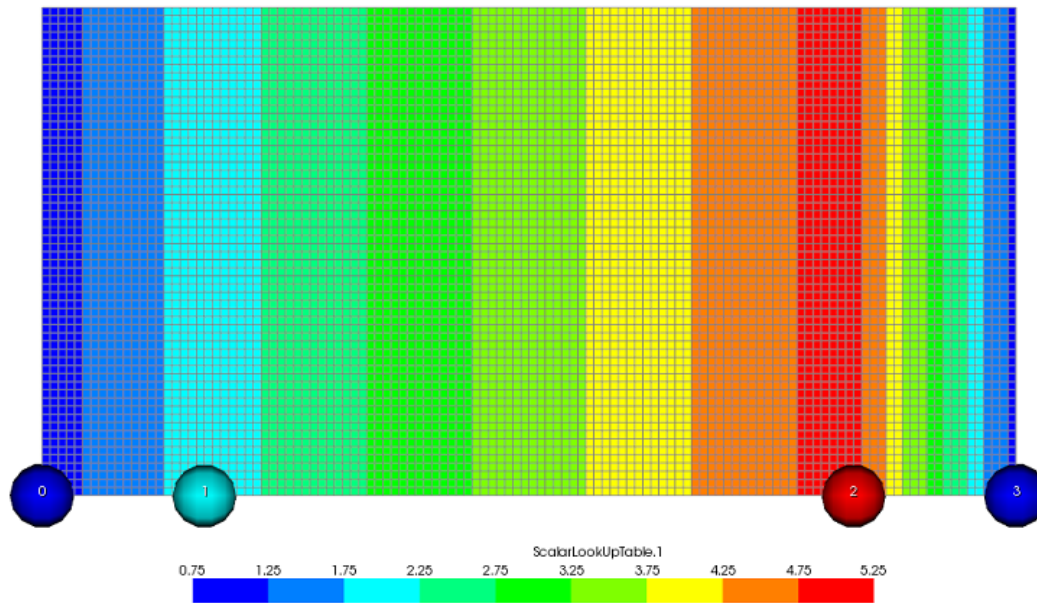

2.1.17.6. Field Definition Plot

The Field Definition plot enables you to visualize and investigate the effect of a [Field Definition](#) (p. 165). This plot is only available ply-wise.

For this plot type, the specific option of the **General** tab is the Field Variable Name. You select the field variable to be plotted from this drop-down menu.

2.1.17.7. Lay-Up Mapping Plot

The purpose of the lay-up mapping plot is to show the result of the lay-up mapping (mapped Composite Definitions onto a solid mesh). It also allows you to check the quality of the mapping result. Therefore, the scope only accepts Imported Solid Models and the property `Show on Solids` is always checked.

For this plot type, the specific option of the **General** tab is the Data Scope option. Using this entry field, specify one or more Imported Solid Models.

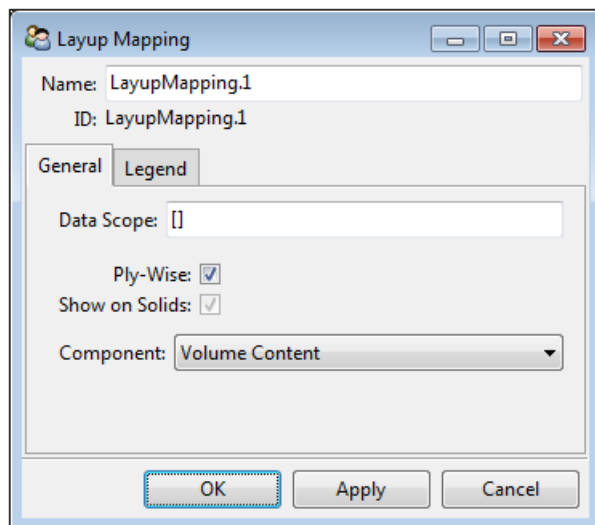
Figure 2.159: Lay-Up Mapping General Properties Tab

Components

The component options for this plot include:

- **Volume Content:** show the ply-wise volume contents
- **Deviation in Normal Direction:** show the difference between the shell normal and layered solid normal direction. If ply-wise is disabled, the average normal deviation of the element is shown.

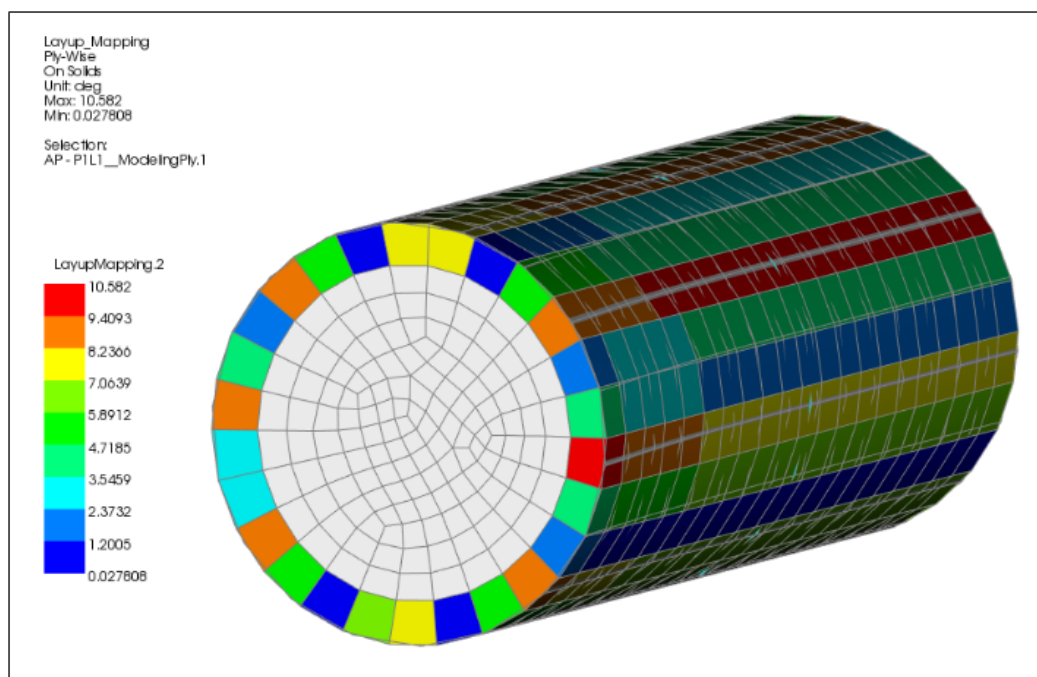
Figure 2.160: Deviation of the Normal Direction between Shell Elements and Layered Solid Elements

2.1.17.8. Material Plots

The Material Plot allows you to visualize ply-wise variable [material properties](#) (p. 303). You must select an Analysis Ply to display the distribution of the material properties.

2.1.17.9. User-Defined Plot

With the User-Defined Plot, you can specify arbitrary scalar quantities for plotting.

2.1.18. Scenes

Scenes are windows that contain the visualization settings of the composite model. New Scenes can be added or existing ones can be modified by hiding or showing visualization features. The visualization of the following features is saved in a Scene:

- Element Sets
- Edge Sets
- CAD Geometries
- Rosettes
- Section Cuts
- Solid Models

In a new Scene, all Element Sets, Section Cuts and Solid Models are shown.

In the **Scene Properties** dialog you can set the **Name** and **Title** which are displayed in the top right corner of the Scene.

Figure 2.161: Scene Properties

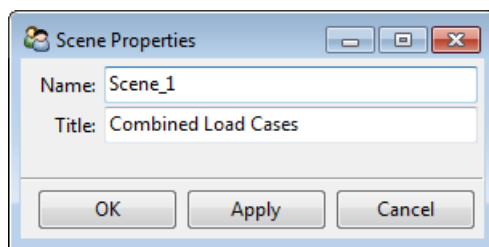

2.1.19. Views

Views can be used to save a certain view. The selection of a view automatically updates the Scene and transfers the properties of the View to the active Scene. New Views can be created with the button in the toolbar (see [Scene Manipulation](#) (p. 23)) or via the object Tree. Different parameters can also be defined manually.

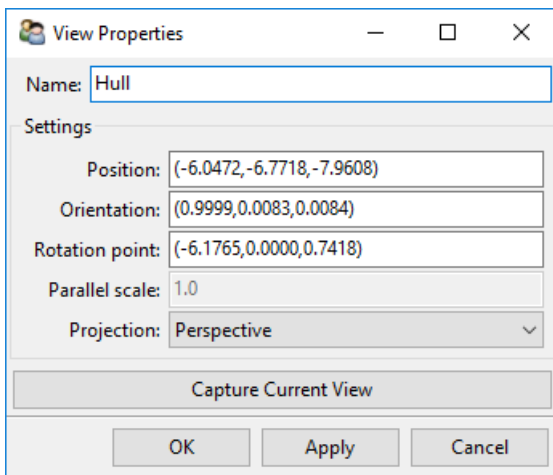

2.1.20. Ply Books

A Ply Book is a document you can create which describes the production plies in your model. It is a convenient way to forward production data to other members of your project such as designers or manufacturers.

The Ply Book is separated into Chapters. Each Chapter lists the production plies belonging to a selected set of **Modeling Groups** or **Modeling Plies**. You can also add to the Chapter a Snapshot image of the plies. For each Chapter you will assign a specific View which determines the camera angle for the Snapshot.

You can customize the content of the Ply Book by defining templates for the different sections as described below in [Editing the Ply Book Template \(p. 235\)](#).

The following sections explain the Ply Book in detail:

- [2.1.20.1. Creating Chapters](#)
- [2.1.20.2. Chapter Properties](#)
- [2.1.20.3. Editing the Ply Book Template](#)
- [2.1.20.4. Modifying the Ply Book Snapshots](#)
- [2.1.20.5. Exporting the Plybook](#)
- [2.1.20.6. Sample Ply Book Page](#)
- [2.1.20.7. Ply Book Limitations](#)

2.1.20.1. Creating Chapters

Before creating any Chapters for the Ply Book, at least one View must be defined. See [Views \(p. 233\)](#) for more information.

Next, you create a Chapter or Chapters by selecting the **Automatic Setup** or the **Create Chapter** option found in the **Ply Book** context menu.

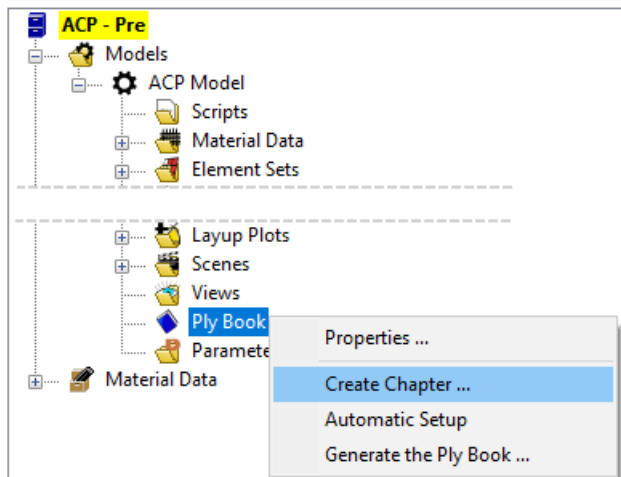

- **Create Chapter:** This option creates one new Chapter and opens its **Chapter Properties** (p. 235) dialog.
- **Automatic Setup:** This option creates one Chapter for each Modeling Group in your model. If needed, you can change any of the Chapter Properties later.

2.1.20.2. Chapter Properties

You can set the following properties for each Chapter:

- **Name:** A descriptive title for the Chapter.
- **Chapter View:** The View used when the ply Snapshot is taken.
- **Modeling Groups / Plies:** Select a list of Modeling Groups or Modeling Plies. The Chapter will contain all production plies contained in these Modeling Groups or Modeling Plies, in the selected order.
- **Show rosettes:** If this check box is ticked, the rosettes associated with a given production ply (through its modeling ply's oriented selection sets) will be shown in the Snapshot images

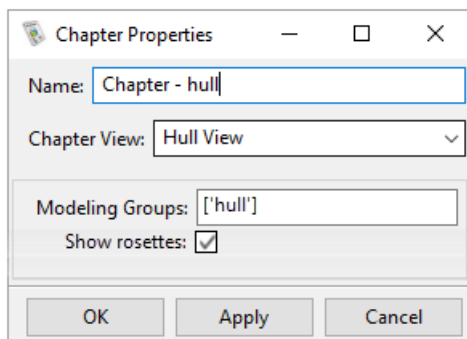

2.1.20.3. Editing the Ply Book Template

The format and content of the Ply Book is determined by three templates, each for a different part of the Ply Book:

- **Title page:** Information shown at the very beginning of the Ply Book
- **Chapter:** Information shown at the start of each Chapter
- **Ply:** Information for each individual production ply

To edit the templates, right-click **Ply Book** in the **Tree View** and select **Properties**. This opens the **Ply Book Properties** window shown below. Use the dropdown menu (A) to select the template for the **title page**, the **chapter**, or the **ply**.

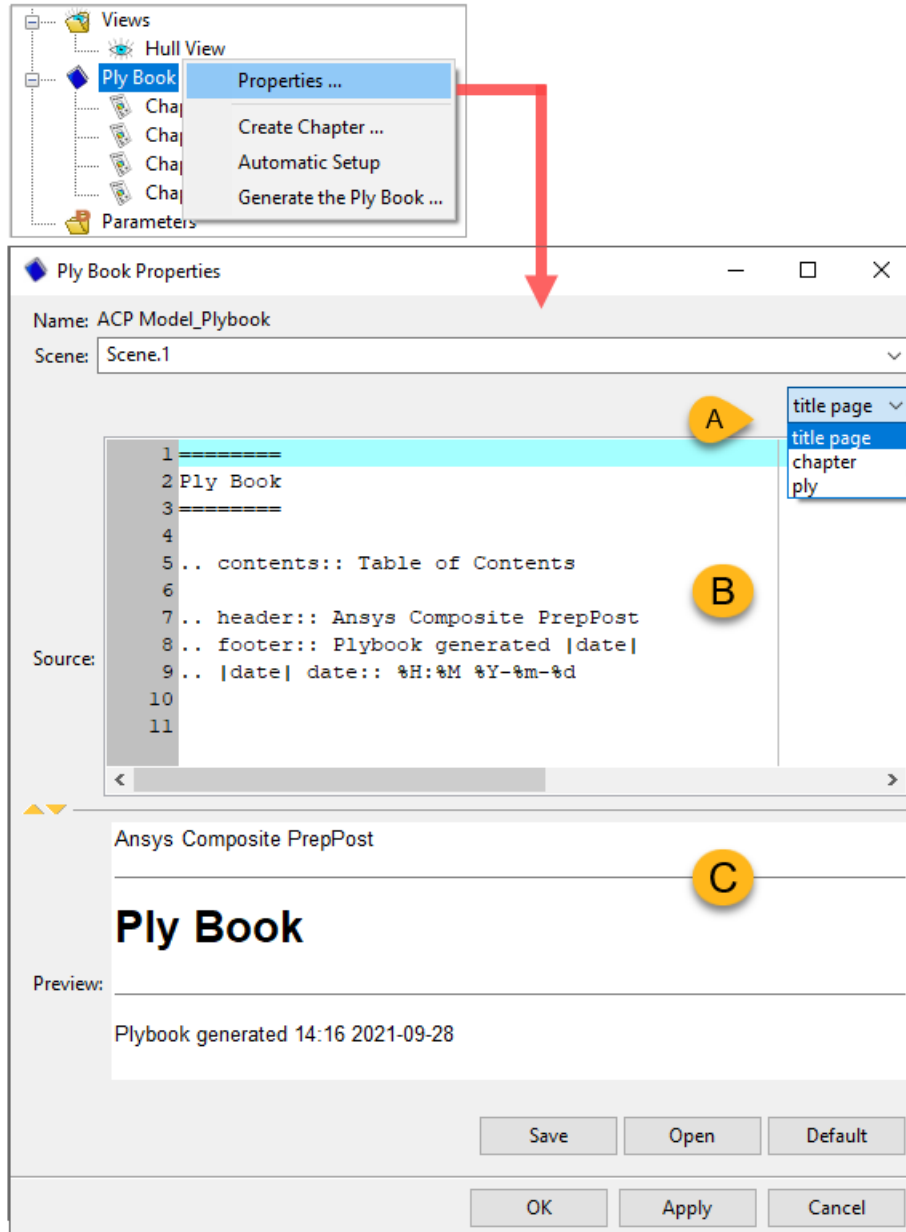

When you select the **chapter** or the **ply** template from the menu (A), additional menus (as shown in the image below) appear in the **Ply Book Properties** window so you can select the specific Chapter and/or production ply template which will appear in the **Preview**.

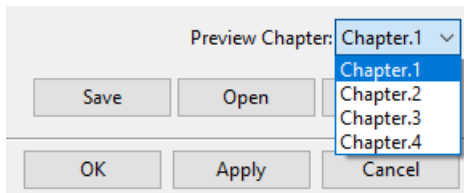

Use the **Source** panel (B) to edit the template using [reStructuredText markup format](#). Your modifications will appear in the **Preview** panel below.

- **Save:** Saves the reStructuredText template to an external text file.
- **Open:** Allows you to open an external text file as a reStructuredText template.
- **Default:** Restores the template to its default format and content.
- **OK:** Save the templates and close the Properties dialog.
- **Apply:** Save the template and update the ACP model.

The **Scene** dropdown menu is explained below in [Modifying the Ply Book Snapshots \(p. 238\)](#).

2.1.20.3.1. Python Expressions

For the Chapter and Ply Templates, you can use [Python expressions \(p. 56\)](#) to print information about the current Chapter and/or ply.

- A Python statement must be enclosed in vertical bars: `|<statement>|`
- The following literals must be present in the statement for it to be evaluated as a Python expression:
 - In the Chapter Template: `chapter`
 - In the ply section, any one of `chapter`, `modeling_group`, `modeling_ply`, or `production_ply`

These are also the variables defined in the Python context.

- The statement `|chapter.view|` has special meaning: It will be replaced by a Snapshot image.

Example:

The following example shows two uses of Python expressions:

- `|modeling_ply.draping_seed_point|`: Adds information about the Draping Seed Point to the Ply Book.
- `|f"{production_ply.thickness:.4f}"|`: Uses [Python formatted string literals](#) to set the precision shown in the ply book.

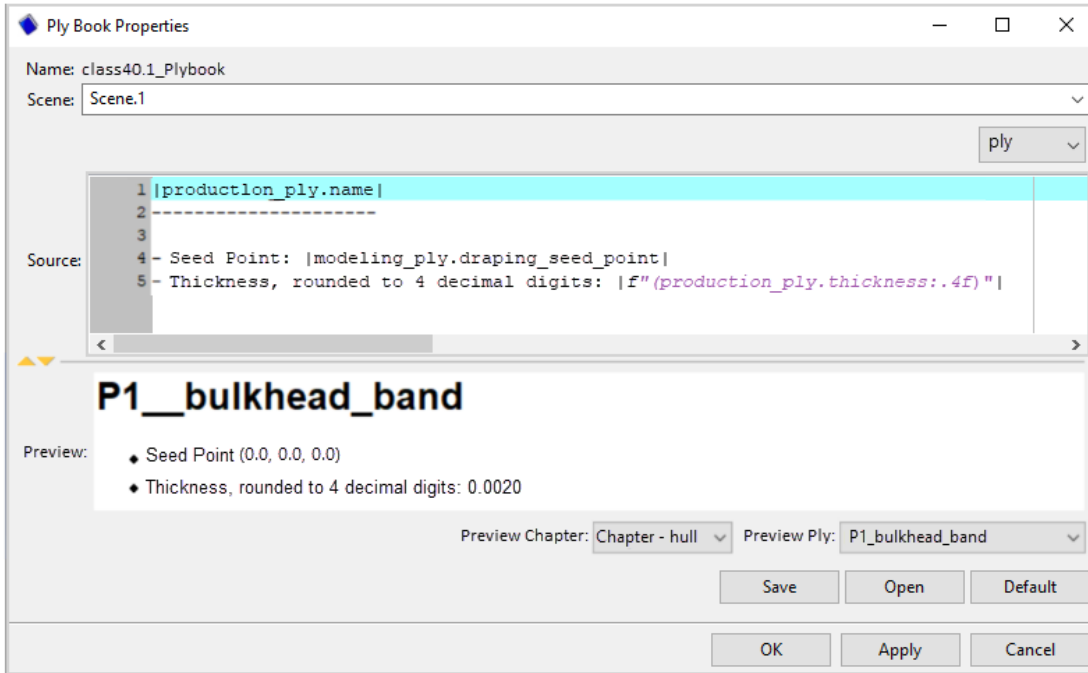

2.1.20.4. Modifying the Ply Book Snapshots

The Snapshot images in the Ply Book use the Scene inked to the Ply Book. You can change which Scene is used in the **Ply Book Properties** window (p. 235).

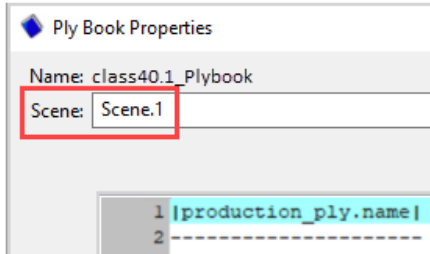

By changing the Scene itself, you can control how the model is rendered, that is, which plots and supporting information are shown. For details on manipulating the Scene, see the following sections: [Scene](#) (p. 23) and [Scene Preferences](#) (p. 19).

You can define the size of the image in the Ply Book using [Scene Preferences](#) (p. 19). If you do not specify its size, it will default to the size of the Scene in the ACP window.

2.1.20.5. Exporting the Plybook

To export the Ply Book, right-click the **Ply Book** object in the **Tree View** and select **Generate the Ply Book** from the context menu. You can export Ply Books in **.html**, **.pdf**, **.odt** or **.txt** formats. The export operation can take several minutes, depending on how many Snapshots are taken.

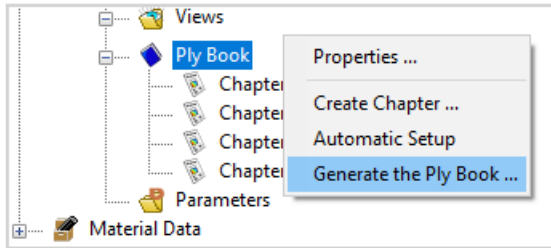

For the **.pdf** output, the paper orientation and size can be selected.

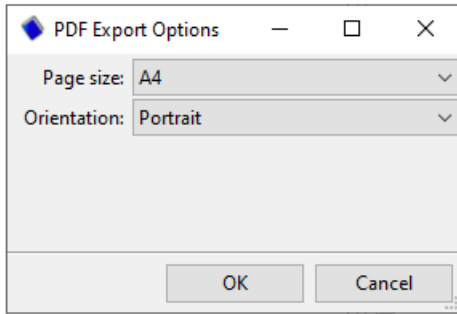

Note:

See the section below, [Ply Book Limitations \(p. 241\)](#), regarding exporting to .odt.

2.1.20.6. Sample Ply Book Page

Below shows a sample Ply Book page. The Scene displays the fiber directions, flat wrap, and rosette used for the ply.

Ansys Composite PrepPost

Chapter - hull

P1__outer_skin_1

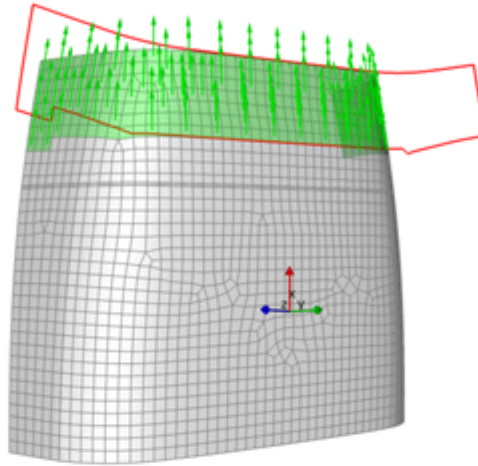
Ansys
2021 R2

- Ply Group Name: hull (hull)
- Modeling Ply Name: outer_skin_1 (outer_skin_1)
- Ply Name: P1__outer_skin_1 (ProductionPly)
- Orientation: 0.0
- Material: E-Glas
- Draping Seed Point: (-4.7643, -0.0, -0.2401)

Parameter	Value
Thickness	0.00027000000000000006
Area	3.703239453349462
Cost	0.0
Weight	1.9998242293937767

Plybook generated 17:38 2021-09-24

2.1.20.7. Ply Book Limitations

.odt export: When exporting to .odt format, the page numbers in the table of contents will be incorrect. To generate the correct page numbers, open the file in a word processor and update the table of contents. For example: In Microsoft Word, right-click the table of contents and choose **Update Field**. In LibreOffice Writer, the command is **Update Index**.

2.1.21. Parameters

The **Parameter** feature connects inputs and outputs to the parameter interface in the Workbench project schematic (see [Working with Parameters in the Workbench User's Guide](#)). You can use this, for example, for creating parametric studies and for optimizing a model.

Figure 2.162: Connection of ACP and Workbench Parameter Interface

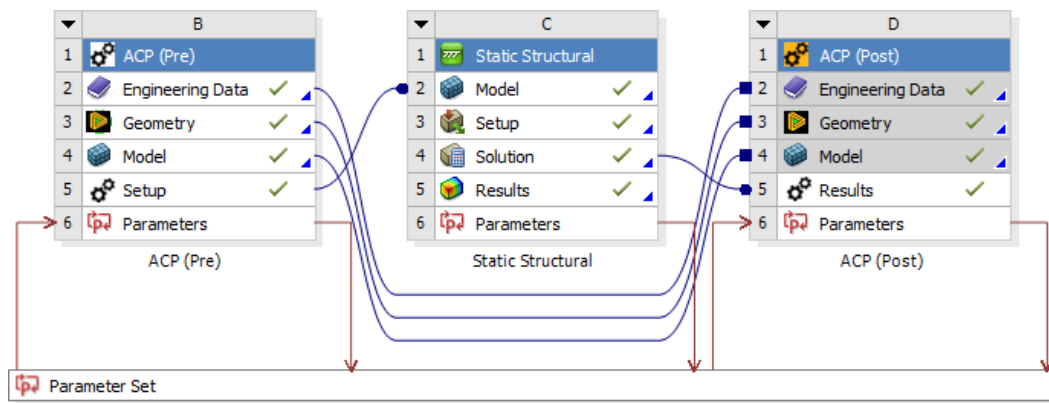

A Parameter is created by selecting **Create Parameter...** in the context menu of the **Parameters** object in the ACP Tree View.

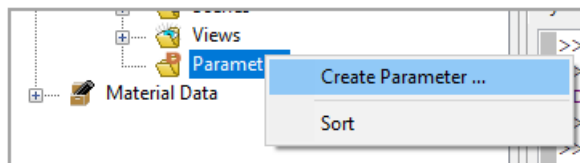

The Parameter connection is then defined in the **Parameter Properties** dialog:

Figure 2.163: Parameter Properties

The screenshot shows a dialog box titled "Parameter Properties" with the following fields and values:

- Name: outer_skin_t.ply_angle
- Description: Ply angle of Modeling Ply outer_skin_4
- Category: Input
- Object: outer_skin_4
- Property: Ply Angle
- Type: Float
- Value: 45.0

Buttons at the bottom: OK, Apply, Cancel.

- **Category:**
 - **Input:** Input parameter taken from the Workbench Parameter interface
 - **Unbound Input:** Input parameters that are not directly linked to other ACP objects. They are mainly used in combination with [Scripts \(p. 71\)](#). Note that unbound inputs do not have the **Object** or **Property** properties.
 - **Output:** Output parameter given to the Workbench Parameter interface
 - **Expression Output (p. 243):** Output parameter that can contain a regular ACP script
- **Object:** The object on which the parameter acts.
- **Property:** The property of the object to be parameterized.
- **Type:** The parameter format. Determined automatically if there is only one possible option. Units are not transferred from ACP to Workbench. Parameters appear as dimensionless numbers in the Workbench interface.
 - **Bool:** Boolean (true or false).
 - **Float:** Real number.
 - **Int:** Integer.
 - **None:** Default selection if multiple options are available.
 - **String:** Text string from a list of strings. The values in the string list can be called up via an index number in the Workbench interface. The first entry in the string list has the index value 1. The rest follows sequentially.

- **Value:** The current value of the parameter. This option can be modified depending on if a parameter is an **Input** or an **Output**.

Caution:

The ACP systems do not automatic convert Parameter units in the Parameter Manager. Always verify that the units of any ACP-related Parameter are consistent with the unit system selected in the ACP system.

For Parameters in ACP (Post), linked to an object in ACP (Pre), the Parameter will become invalid if you rename the ACP (Pre) object. To correct, redefine the source object for the Parameter.

2.1.21.1. Settings for an Expression Output

The formulation of an expression output requires a basic understanding of [The ACP Python Scripting User Interface](#) (p. 56).

The **Parameter Properties** dialog displays a **Source** field that accepts Python code. Various information stored in the ACP database can be accessed. It is possible to enter a script and perform most of the operations available within ACP's Shell View.

The script's result can be returned by assigning a value to the global `return_value` variable.

Example 2.1: Simple Expression Output

An example of a simple expression output is shown here. In it, the maximum inverse reserve factor is retrieved from the active contour plot.

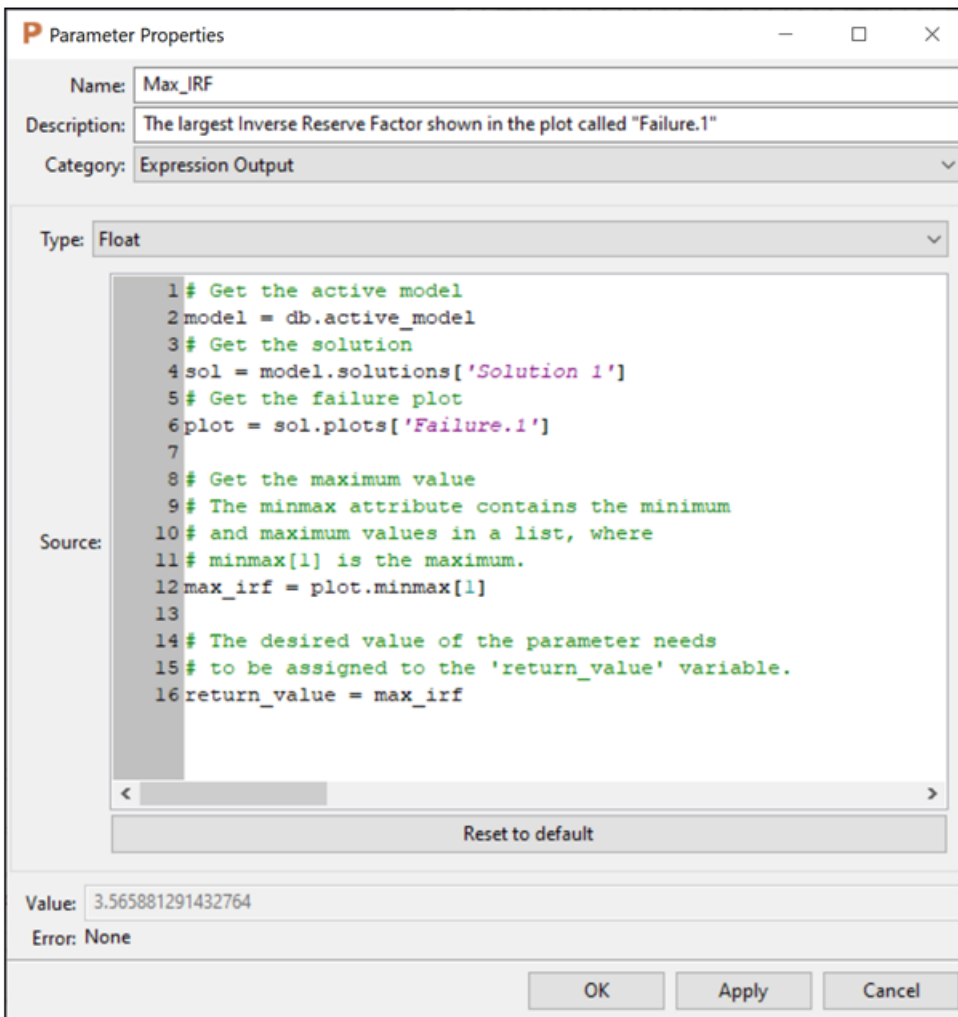

Example 2.2: Complex Expression Output of Maximum Thickness in the Kiteboard Model

```

# Get active model
model = db.active_model

# Create new selection of all elements attached to a specific ply
modeling_ply = model.modeling_groups['Core'].plies['mp_4']
model.select_elements(selection='sel0', op='new', attached_to=[modeling_ply])

# Get total thickness of the first entity of selection sel0
thicknesses = list(model.mesh_query(name='thickness', position='centroid', selection='sel0', entities=[modeling_ply]))

# Get maximum thickness
max_thickness = max(thicknesses)

# Pass the found maximum thickness as the script's result.
return_value = max_thickness

```

2.1.22. Material Database

It is possible to build a Material Database which can be used in different projects. The database can also be saved on an intranet drive for sharing to other ACP users.

The structure of the Material Database is exactly the same as in the model. For more information, see [Material Data \(p. 74\)](#). The database is stored as `.acpMdb` and it can be managed through the context menu:

Figure 2.164: Material Database

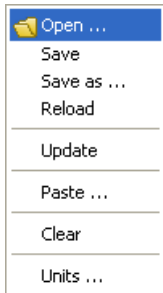

The units of the database and the model can be different. Use **Copy** and **Paste** to transfer a material from one to the other. Values of the materials are converted automatically to the correct unit system.

A default Material Database is installed with ACP: `ANSYS_INSTALL_DIR\v251\ACP\databases`.

2.2. Exchanging Composite Definitions with Other Programs

This section describes how data can be exchanged between ACP and other programs. The following interfaces are available:

- 2.2.1. HDF5 Composite CAE Format
- 2.2.2. Mechanical APDL File Format
- 2.2.3. Import of Legacy Mechanical APDL Composite Models
- 2.2.4. Tabular Data Format for Excel
- 2.2.5. CSV Format
- 2.2.6. ESAComp
- 2.2.7. LS-Dyna
- 2.2.8. BECAS

2.2.1. HDF5 Composite CAE Format

HDF5 Composite CAE is a vendor-independent specification that allows an accurate exchange of composite lay-ups between different CAE and CAD packages. The specification uses HDF5 for data storage, an open and widely used file format that efficiently stores binary data (<http://www.hdf-group.com/>). Many specialized simulation tools (for forming and winding simulation, for example) support this format, which enables a seamless data transfer into Ansys Workbench – ACP to run a structural, thermal, modal, or buckling analysis. The format and interface contain all the necessary information such as ply surfaces, fiber directions, thicknesses, stacking sequence, and materials.

ACP supports the export and import of the HDF5 Composite CAE format. The interfaces are accessible through the **ACP Model** context menu (p. 62).

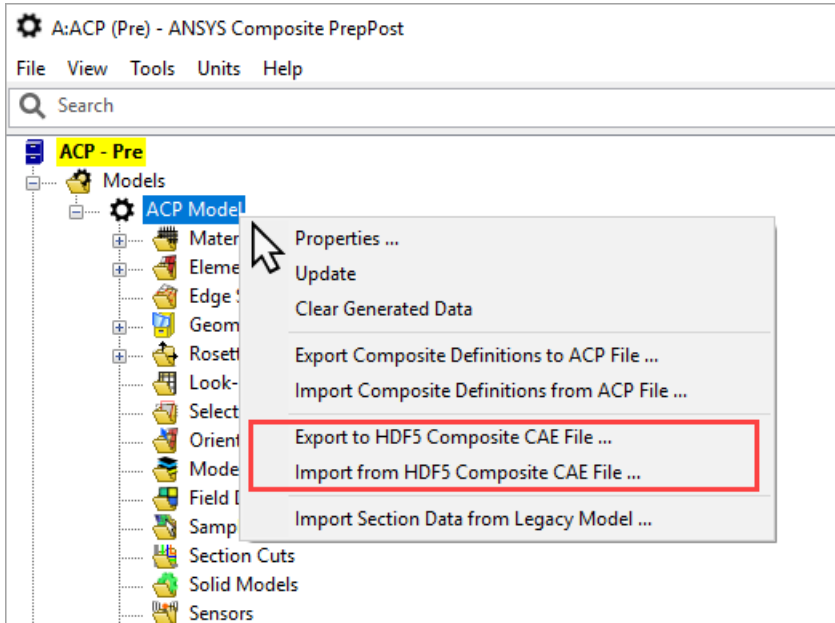
Figure 2.165: Export and Import Options in Model Context Menu**Note:**

The HDF5 Composite CAE format does not take the [Fabric Fiber Angle \(p. 78\)](#) property into account. As a result, if the Fabric Fiber Angle property is active in ACP when the composite lay-up is exported, Mechanical properties might not be accurate.

2.2.1.1. Export

Only the effective lay-up in ACP is extracted during the HDF5 Composite CAE export. This means, for example, ACP will export the ply's thickness distribution but not the taper definitions that affect the ply's thickness. Neither will it export the reference shell surface. It will, however, extract Information on the ply's material, coverage, dimensions, thickness distribution, reference direction field, as well as the overall ply sequencing. All this information gets stored in the .H5 file.

You can then import the extracted data into a program such as FiberSIM for further design and production management.

For Export Settings, refer to the dialog box below and the explanations which follow.

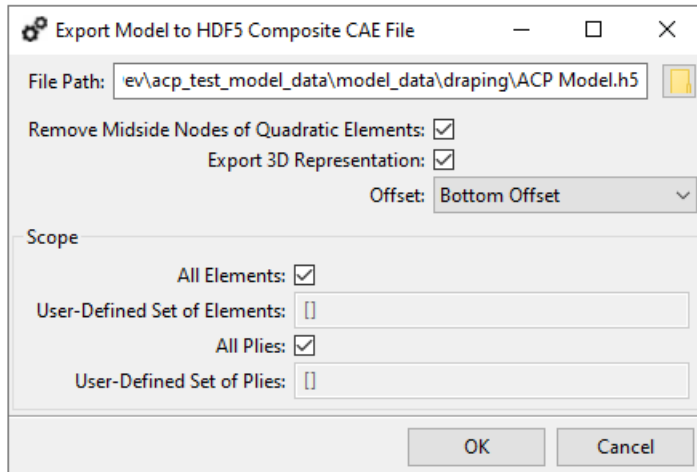
Figure 2.166: HDF5 Composite CAE File Export Settings

- **File Path:** Specify the destination file name and file path.
- **Remove Midside Nodes of Quadratic Elements:** By default, midside nodes of the quadratic elements are not exported.
- **Export 3D Representation:** If enabled, a 3D representation of the ply surfaces (including the offsets from the reference surface) and is computed and exported. (An example is shown in the figure below.) The reference surface, the stacking sequence, and the ply thicknesses of the other plies in the laminate determines the exact 3D location of the ply surface. If **Export 3D Representation** is *not* enabled, the ply geometry is based on the reference surface only.

Note:

If you intend to import the HDF5 Composite CAE file into an external application, you must verify which representation it requires. The standard representation is shell surface, in which case you should *not* enable **Export 3D Representation**.

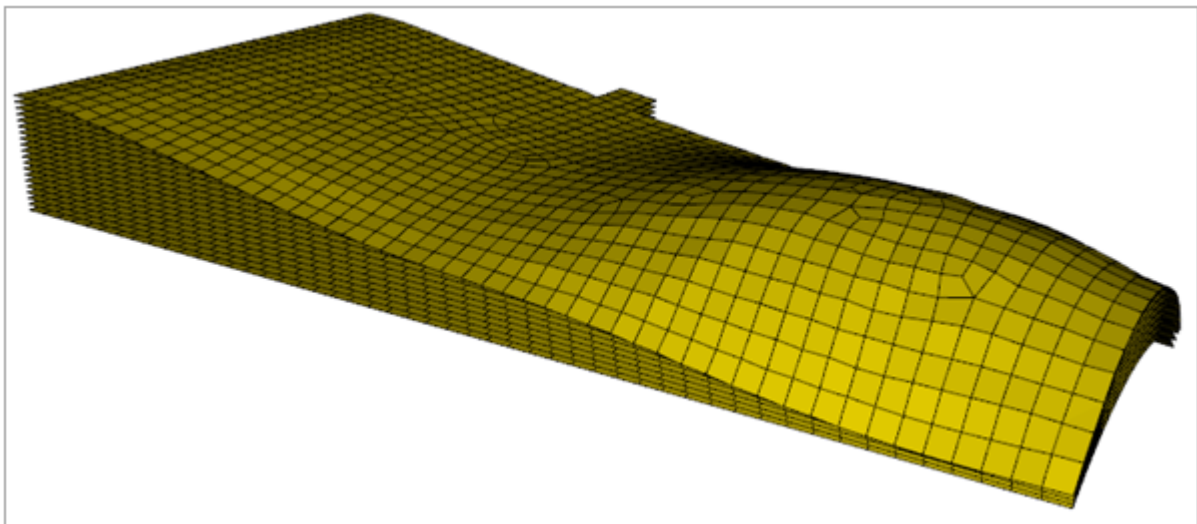
Figure 2.167: 3D Representation of a Lay-Up with Offset Ply Surfaces

- **Offset:** Select the surface for export: the bottom, mid, or top surface of the plies. The default is **Bottom Offset**. The **Offset** option is available only when **Export 3D Representation** is enabled.
- **Scope:**
 - **All Elements:** Uncheck this option to restrict the lay-up export to a region of interest.
 - **User Defined Set of Elements:** Here you can limit the exported plies to the specific Element Sets and/or Oriented Element Sets that interest you.
 - **All Plies:** By default, all plies of the scope are exported. Uncheck this option to select a user-defined set of plies to be exported.
 - **User Defined Set of Plies:** Specify the set of Modeling Plies and/or Modeling Groups to be exported.

Note:

The 3D lay-up representation cannot be generated for complex shapes and topologies. In those cases, it can help to export sub-areas only by using the user-defined set of elements and user-defined set of plies options in the export dialog. See [Figure 2.166: HDF5 Composite CAE File Export Settings \(p. 247\)](#).

2.2.1.2. Import

When importing an HDF5 Composite CAE, you must have a model already loaded in ACP. This is because ACP will take the lay-up definitions from the HDF5 Composite CAE and apply them to the model as explained in the next section.

When using ACP within Workbench, the model of the upstream Mechanical component is automatically loaded in ACP as described in [Basic Workflow \(p. 39\)](#). You can use the [External Model component](#) in Workbench to import an external mesh model of almost any format, and then you can transfer it to ACP as shown here.

Figure 2.168: The External Model Component in Workbench

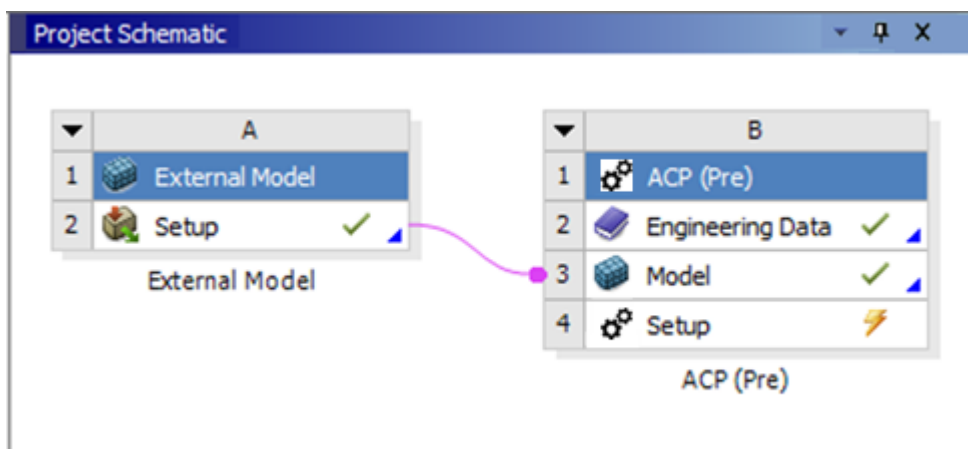

If ACP runs in standalone mode, you can load a mesh model from a `.cdb` file (Mechanical APDL format) as shown in the section [Workflow in Stand Alone Operation \(p. 58\)](#). It is important to understand, the mesh(es) from a HDF5 Composite CAE cannot be loaded directly as a model.

Furthermore, when using ACP within Workbench, materials are *not* directly imported into ACP because materials are always loaded from Engineering Data. This can cause a newly generated Fabric to lose the link to its material if no material with a matching name exists in Engineering Data. Here is a workaround:

1. First, extract the materials from the HDF5 Composite CAE file as explained in the section, [Extract Materials From Composite CAE H5 \(p. 14\)](#).
2. Then import the generated MatML file into Engineering Data.
3. Finally, import the HDF5 Composite CAE file into ACP.

Another option is to add the materials to Engineering Data manually. You can use HDF View (a third-party application) to open the HDF5 Composite CAE file and look up the material names.

2.2.1.2.1. Import Projection Types

The HDF5 Composite CAE Import supports two types of projections. The first one *maps lay-up data onto the shell mesh (reference surface) in ACP*. The second option *directly converts the ply data from the Composite CAE H5 into Imported Plies Objects (p. 160) in ACP*. Below is a more detailed explanation of each projection type.

Mapping onto The Reference Surface

During the import process, the mapping algorithm in ACP begins by computing the ply extent with respect to the reference surface in ACP. It then maps the fiber directions, thicknesses, and other properties onto the surface. Ply material information gets transferred to the Material Data object in ACP, and Oriented Selection Sets are generated based on ply coverage. Finally, thickness distributions and reference direction fields are stored in Look-Up Tables which are then used to define the modeling plies in the lay-up reconstruction.

A ply in the Composite CAE H5 has its own mesh that typically differs from the reference surface in ACP, requiring an adjustment to the mapping parameters. For example, different mesh sizes on curved surfaces can cause element normals to deviate. Nodal locations in the out-of-plane and in-plane directions can also vary, depending on mesh sizing

You can manage these effects with appropriate import tolerances. Large tolerances can result in mapping issues, especially with convergent meshes, as with a T-joint. If the tolerances are too large, ply boundaries cannot be accurately replicated.

Exposed as 3D Plies (Imported Plies)

Instead of mapping the composite data of the HDF5 Composite CAE onto the reference surface in ACP, the data is directly converted into Imported Ply objects if the projection is set to **Expose as 3D Plies**. Since each Imported Ply has its own mesh that is independent of the reference surface, the meshes of the HDF5 and Imported Plies are identical.

This enables you to build complex 3D lay-up models in a CAD environment and load it into ACP for detailed analyses.

The remaining data, such as Thicknesses and Reference Direction, are stored in the same manner as the **Mapping onto the Reference Surface** import option.

Ply material information gets transferred to the Material Data object in ACP. Thickness Distributions and Reference Direction Fields are stored in look-up tables which are then used to define the Imported Plies.

2.2.1.2.2. Import Settings

A number of settings and tolerances control the import of the composite model. Refer to the dialog box below and the explanations which follow.

Figure 2.169: HDF5 Composite CAE File Import Settings

Path

Specify the path to the .h5 file you wish to import.

Import Mode

- **Append:** Imported data and objects will be appended to the existing model/lay-up.
- **Overwrite:** Replaces existing objects that have the same id, unless objects are locked. Note: To preserve the ply ordering specified in the HDF5 Composite CAE file, imported plies will be added to the top of the existing lay-up, or moved to the top if they already exist.

Projection

For additional information on Projection types, [see the detailed explanation above](#). (p. 249)

- **Map onto Reference Surface:** This option maps the plies onto the shell surface in ACP and exposes them as Modeling Plies.
- **Expose as 3D Plies (Imported Modeling Plies):** This option converts the plies into Imported Modeling Plies, uncoupled from the reference surface.

Ply Angles

- **Minimum Angle Tolerance:** Minimum angle tolerance for which tabular correction angles are computed for plies.
- **Recompute Reference Directions:** When this option is selected, reference directions are recomputed from tabular angle data.

Mapping Scope

- **All Elements:** By default, the lay-up data specified in the .h5 file is mapped onto all the elements of a reference shell mesh in ACP. Uncheck this Boolean to restrict the lay-up mapping to a user-defined region of interest.
- **User-Defined Set:** The lay-up data is mapped onto the Element Sets specified here.

Ply Area Mapping

Refer to the [Figure below](#) (p. 252) for an illustration of the Tolerance Settings.

- **Relative Thickness Tolerance:** This sets the mapping tolerance in the element thickness direction relative to a minimum element edge length. In the [dialog box](#) (p. 250) shown above, assuming a minimum edge length of 1mm, elements will be mapped if their deviation in the element thickness direction is between -0.5 and 0.5 mm.
- **Relative In-Plane Tolerance:** This sets the mapping tolerance in the element in-plane direction relative to a minimum element edge length. In the [dialog box](#) (p. 250) shown above, assuming a minimum edge length of 1mm, elements will be mapped if their in-plane coordinates are within the shell mesh with a maximum allowable tolerance of 0.01mm.
- **Angle Tolerance:** Mapping tolerance for angles between element normals (in degrees).
- **Small Hole Threshold:** Holes in plies/Element Sets with an area smaller than this threshold times the area of the Element Set/ply are filled.

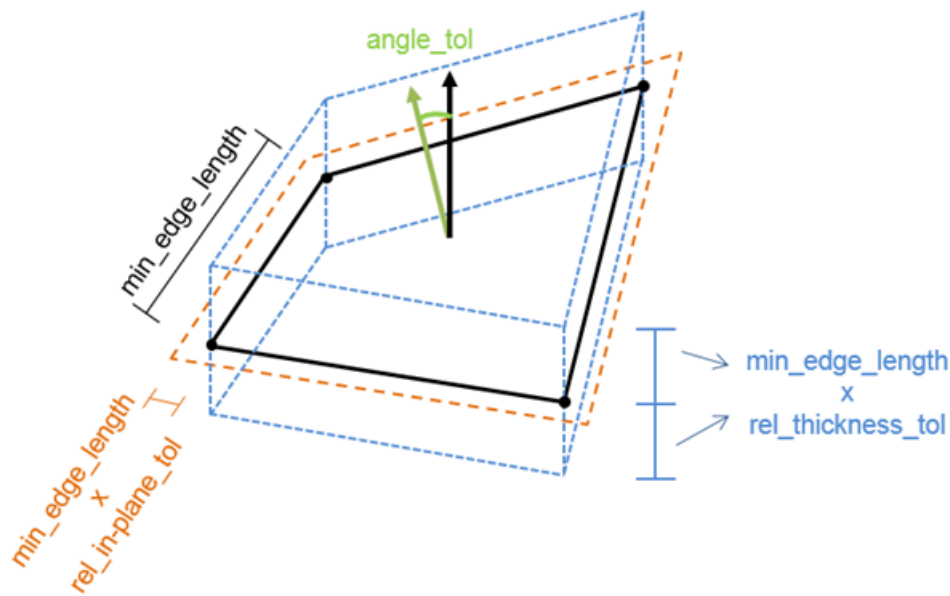
Figure 2.170: Schematic of Tolerance Settings for a Single Element

Coordinate Transformation

The imported Composite Definitions are transformed according to the inputs given here. The transformation order is as follows:

1. Rotation around X-Axis
2. Rotation around Y-Axis
3. Rotation around Z-Axis
4. Translate X, Y, Z

The X, Y and Z rotation happens around three axes of ACP's global coordinate system. All angles must be specified in degrees.

Show/Update Mesh Preview

Clicking this button displays a preview of all the meshes in the hdf5 file after the coordinate transformation has been applied.

2.2.2. Mechanical APDL File Format

A Mechanical APDL input file requires specific element settings if it is to be used with ACP in Stand Alone mode. This applies to preprocessing models that are used to define a composite lay-up as well as postprocessing models where reading stresses and strains in future analyses is required. For more information, see [Workflow in Stand Alone Operation \(p. 58\)](#).

Nodal solutions can be loaded from:

- **PRNSOL** file formats. An example export could be:

```
/format,10,G,25,15,1000,1000
prnsol,u
prnsol,rot
```

- The `.rst` file interface allows ACP to load nodal and element results directly from the Ansys result file.

Use these options for element result import:

- SHELL181: Keyopt(8) = 2 (See Figure 2.171: SHELL181 Keyopts (p. 253))
- SHELL281: Keyopt(8) = 2 (See Figure 2.172: SHELL281 Keyopts (p. 254))
- SOLID185/SOLID186: Keyopt(3) = 1 (See Figure 2.173: SOLID185 Keyopts (p. 254) and Figure 2.174: SOLID186 Keyopts (p. 254))

Keyopt(3) must be defined via the command line: **KEYOPT**,*ET_NUM*,3,1

- SOLSH190: Keyopt(8) = 1
- **ERESX**,NO (copy integration point results to nodes)

Supported shell and solid (for post-processing only) element types: SHELL181, SHELL281, SOLID185, SOLID186

Supported element property definition commands: **SECTYPE**, **SECOFFSET**, **SECCONTROL**, RLBLOCK

Figure 2.171: SHELL181 Keyopts

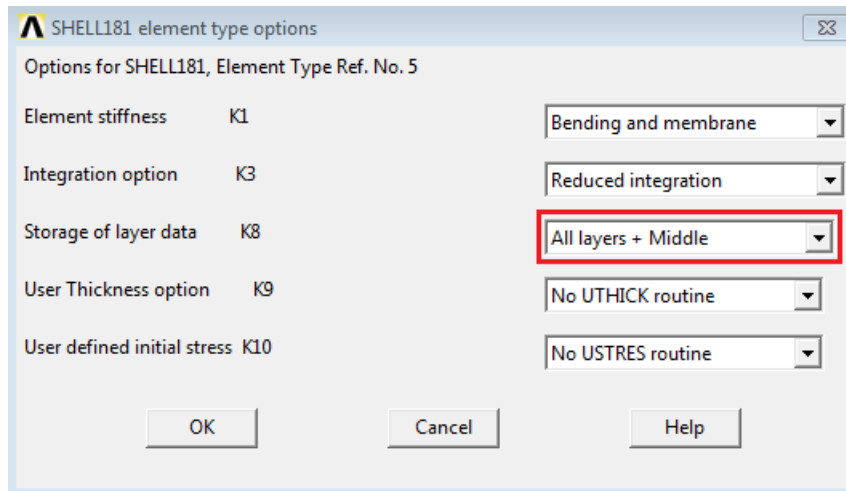
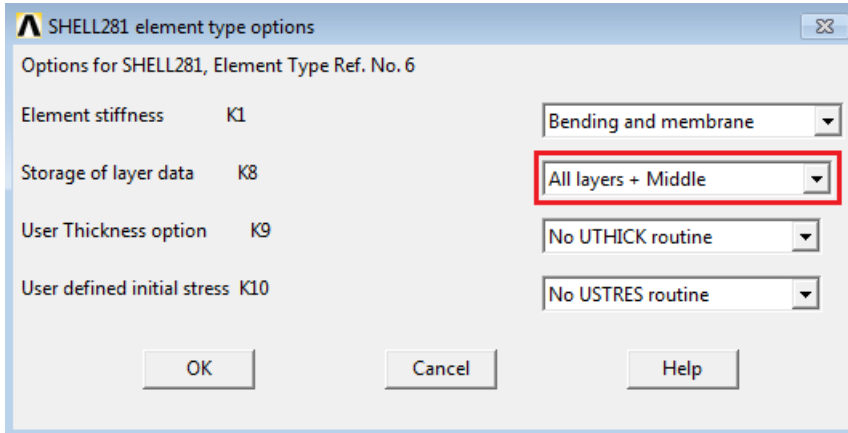
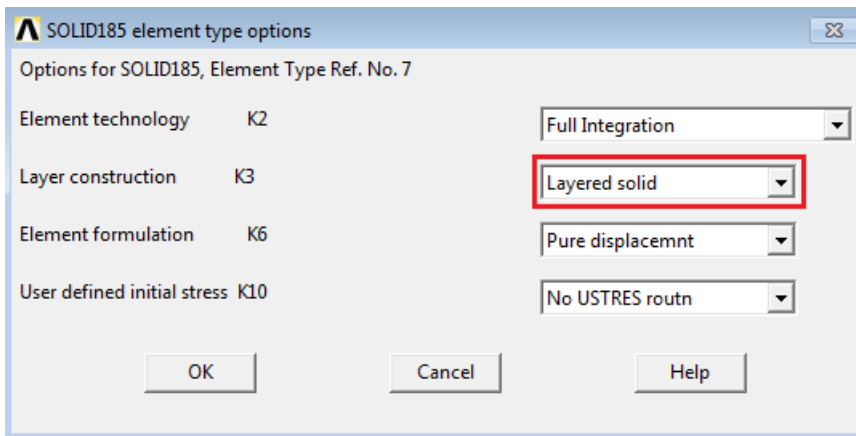
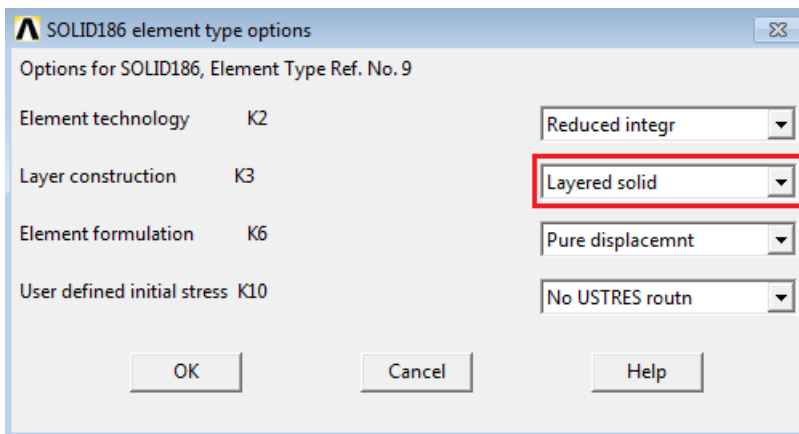

Figure 2.172: SHELL281 Keyopts**Figure 2.173: SOLID185 Keyopts****Figure 2.174: SOLID186 Keyopts**

2.2.3. Import of Legacy Mechanical APDL Composite Models

You can import composite shell models with section definitions created in Mechanical APDL to ACP. Upon import, the lay-ups are converted into ACP Composite Definitions (Rosettes, Oriented Selection

Sets and Modeling Plies). The converted model can be subsequently used in Workbench projects. See the [Special Cases \(p. 256\)](#) and the [Known Limitations \(p. 257\)](#) sections for more information.

Review the following import scenarios. The scenarios are different based upon whether or not you are working with the mesh of the legacy model in ACP.

Equal Meshes

In this case, the section definitions of the legacy model are mapped according to the element labels. It also assumes that also the element normals are equal.

To import a legacy model that can be used in Workbench projects:

1. Add an **External Model** system to the Workbench project page and load the legacy file.
2. Add a new **ACP (Pre)** system to the Workbench project page.
3. Link the **External Model** system with the **Engineering Data** cell of the ACP system. This loads the materials (cells A2-B2).
4. Link the **External Model** system with the **Model** cell of the ACP system in order to load the mesh (cells A2-B3).
5. Refresh the ACP system **Setup** cell. Launch ACP.
6. Make sure that the unit system in ACP and the legacy model are the same.
7. From the action menu of the **Model** folder in ACP, select the option **Import Section Data from Legacy Model**. Select the file you have opened in the **External Model** system (see [Import Section Data from Legacy Model \(p. 68\)](#)). Verify that you have the correct material mapping mask.

Figure 2.175: Configuration Overview

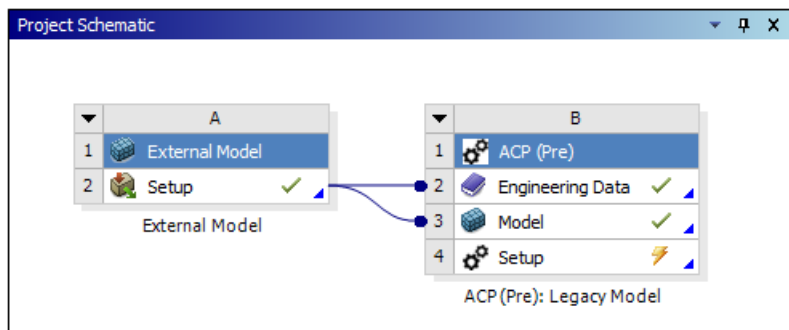

Note:

- Engineering Data renames the materials. The pre- and suffix masks enables the automatic mapping between legacy material IDs and WB material IDs.
- Import each legacy model separately because the mapping is based on the element labels. You can assemble the legacy files in a downstream Mechanical Model as needed.

To import a legacy model in ACP standalone mode:

1. Start ACP in ACP standalone.
2. Load the file using the **Import Model** option from the Models action menu or File tab in the application toolbar and select the **Convert Section Data** check box.

Different Meshes

If you are working with different meshes, you have to convert the legacy model by using the Composite CAE H5 file format.

To convert a legacy model onto a different mesh:

1. In Workbench, import and convert the legacy model as described above (system A and B)
2. Update ACP **Setup** cell (A4) and [export the lay-up to a HDF5 Composite CAE file \(p. 68\)](#).
3. Create the ACP system (C) where you want to map the legacy lay-up to.
4. Link the **External Model** with the Engineering Data component to load the materials (A2-C2).
5. Open the ACP **Setup** cell (C5) and [import the Composite CAE H5 file \(p. 68\)](#).

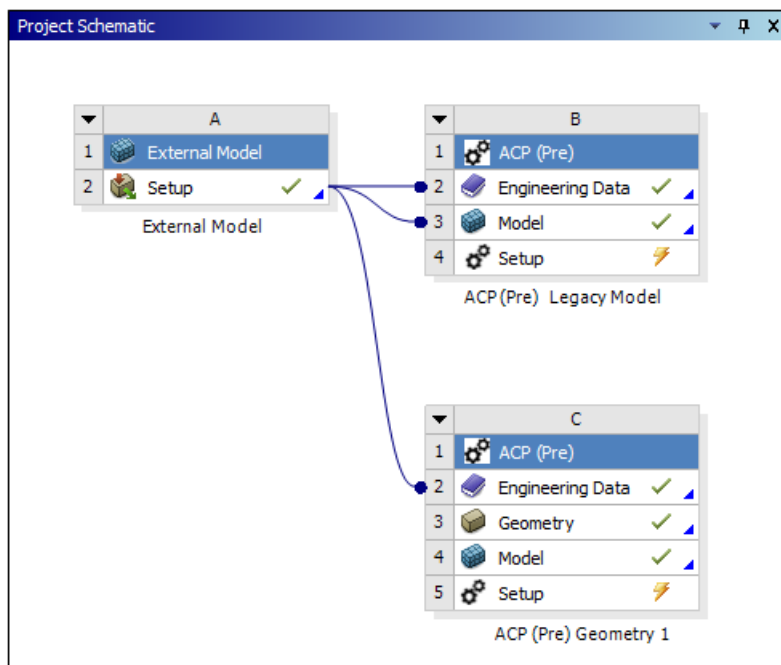
Figure 2.176: Configuration Overview**2.2.3.1. Special Cases**

Lay-ups in ACP are either stacked on the top or the bottom of a shell surface. If the shell offset direction of a Mechanical APDL model is not set to top or bottom, then the ply lying on the shell surface is split into two plies on either side of the shell surface during the conversion.

Figure 2.177: A Four Ply Mechanical APDL Lay-up Where a Ply Crosses the Reference Surface is Converted to a Five Ply ACP Lay-up

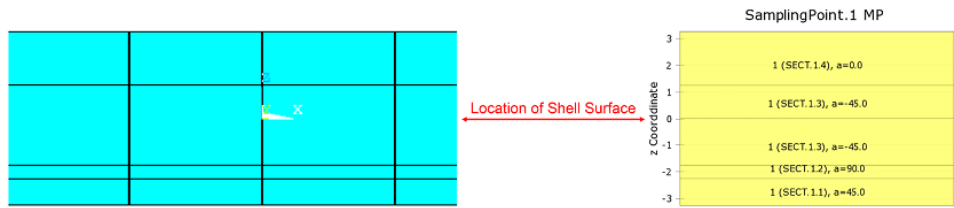

2.2.3.2. Known Limitations

The conversion of the composite lay-up of legacy Mechanical APDL models to ACP models only works for shell models.

The proper translation of Mechanical APDL sections to ACP modeling plies can only be guaranteed if the Mechanical APDL section points to a connected region of elements where all element normals are oriented the same way. If this is not the case, a warning is issued on export and the resulting lay-up may not be entirely correct.

The material transfer from External Model to Engineering Data is not supported on Linux. Alternatively you can load the model in ACP standalone and export the materials in the Ansys Workbench [XML format \(p. 75\)](#) and import from this file.

2.2.4. Tabular Data Format for Excel

A definition block starts with a cell value of BEGIN TABLE and ends with END TABLE. This cell is in the first column (A) of the worksheet. The block DEFINITION is used to identify the type of tabular data defined in the block. ModelingGroup, LookUpTable3D, and LookUpTable1D are currently the only supported definition types.

Empty lines are not allowed inside of sub-blocks. Lines between sub-blocks are ignored. When the lay-up is pushed from ACP, the formatting of existing cells is not changed. Missing field in the DATA block are ignored and not set when synchronized with ACP. Hidden cells are not ignored and are synchronized with ACP.

Figure 2.178: ModelingGroup Tabular Format in Excel

BEGIN TABLE				
BEGIN DEFINITION				
type	ModelingGroup			
id	hull			
name	hull			
END DEFINITION				
BEGIN DATA				
name	id	oriented_selection_set_1_id	ply_material	ply_angle ...
outer_skin_1	outer_skin_1	hull_all	fabrics/E-Glas	0
outer_skin_2	outer_skin_3	hull_all	fabrics/E-Glas	-45
core_bwl	core_bwl	hull_bwl	fabrics/Corecell_A550_25mm	0
END DATA				
END TABLE				

In the case of Look-Up Tables, if you add the text string "(Read Only)" to the column name, the corresponding Excel column is ignored.

Figure 2.179: Look-Up Table Tabular Format in Excel

BEGIN TABLE			
BEGIN DEFINITION			
type	LookUpTable1D		
id	LookUpTable1D.1		
name	LookUpTable1D.1		
origin	0.0, 0.0, 0.0		
direction	1.0, 0.0, 0.0		
END DEFINITION			
BEGIN DATA			
column_names	Location	Value	Index [i] (Read Only)
column_types	location	scalar	-----
dimensions	length	dimensionless	-----
values	0	0	0
	1	1	1
	2	2	2
	3	3	3
	4	4	4
	5	5	5
END DATA			
END TABLE			

References to other objects (ply material, oriented selection sets, etc.) are defined by the object's ID. In the case of ply material, the type of material and the material's ID are joined with a forward slash (for example, fabrics/E-Glass). For the angle and thickness fields, the column name and the ID of the lookup table must be provided (LookUpTable.1/Angle).

Communication to Excel is accomplished through the COM interface. The identifier used to connect to Excel is **Excel.Application**.

You can find more information on how to exchange model data with Excel in [Edit Entities with Excel](#) (p. 24).

2.2.5. CSV Format

Materials, Look-Up Tables, Selection Rules definitions, and Modeling Groups can be exported and imported using a `.csv` format (comma separated value file).

The `.csv` file format for the import and export of Look-Up Tables and Modeling Groups follows the same format as the [Tabular Data Format for Excel](#) (p. 257).

Caution:

The CSV format uses a "," as list separator. In some Regional Options in Windows, the list separator is defined by another character (very often ";"). In this case, the `.csv` files will not be properly read and written by Excel. Change the list separator in Windows Settings.

2.2.6. ESAComp

Model format: ESAComp XML files.

The following operations are available:

[2.2.6.1. Export](#)

[2.2.6.2. Import](#)

2.2.6.1. Export

Material data (Fabrics, Stackups and Sublaminates) and Sampling Points can be exported to ESAComp XML. A Fabric represents a Ply in ESAComp and Stackups; Sublaminates and Sampling Points are exported as Laminates.

To be sure that the imported values in ESAComp are in accordance to the ACP model, the FE import units in ESAComp should be checked first.

- Open FE import and export units in ESAComp.
- Adjust units in the **Model Properties** dialog (see [ACP Model \(p. 65\)](#)).

2.2.6.2. Import

Import

As for the export, check that the units match in ESAComp and Ansys Composite PrepPost.

In ESAComp, there are 2 ways to export the data:

Script Format (recommended)

In ESAComp, you can export Plies and Laminates through the *FE Export / ANSYS ACP* option in the menu. It generates a Python script, in which all the information is stored in ACP format.

XML Format

In ESAComp, export your data as `.XML` file using the File menu. Import this data in Ansys Composite PrepPost with the context menu for the **Material** object in the Tree (see [Material Data \(p. 74\)](#)).

Only material data can be imported.

Important:

The Import from ESAComp XML operation does not create the material in Ansys Composite PrepPost. It only changes the properties. So the material must be created before with the same name as in ESAComp.

2.2.7. LS-Dyna

There are three ways to exchange an ACP composite model with LS-Dyna:

- LS-DYNA (Extension Library): This approach allows you to convert a Workbench model, including Composite Definitions, to an LS-Dyna model. This is the recommended approach.

- LS-Dyna Interface (ACP Add-on): Allows you to define Composite Definitions for LS-Dyna meshes/models.
- LS-Dyna Solid Model (ACP Add-on): Allows you to export to the solid model in the .x file format.

Caution:

The add-on features described in this section are not recommended for general use. It is strongly suggested that you use the Workbench interface to transfer information between ACP and LS-Dyna.

2.2.8. BECAS

ACP can export the 2D mesh of a surface section cut to the cross-section analysis tool BECAS. This allows you to derive a beam model from an ACP shell model.

The 2D mesh is built with linear elements and includes material information and lay-up orientations. As a result, consider both geometric and material-dependent coupling.

The 2D mesh can also be exported to Mechanical APDL. In this case, no lay-up information is transferred.

For more details on exporting surface section cuts, see [Section Cuts \(p. 170\)](#).

For more information on the BECAS tool, see the [BECAS website](#).

Chapter 3: Composite Modeling Techniques

The various composite modeling techniques available in ACP are described in the sections below:

- 3.1. T-Joint
- 3.2. Local Reinforcements
- 3.3. Ply Tapering and Staggering
- 3.4. Variable Core Thickness
- 3.5. Draping
- 3.6. Guide to Solid Modeling
- 3.7. Guide to Composite Visualizations
- 3.8. Guide to Composite Failure Criteria
- 3.9. Element Choice in ACP
- 3.10. Variable Material Data in Composite Analyses

3.1. T-Joint

T-joints are used to bond a primary structure to a secondary one. A good example is a frame with a stringer of a boat hull. **Oriented Selection Sets** (OSS) allow you to define complex laminates by an intuitive approach. For an example of a T-Joint analysis, see [T-Joint Tutorial](#).

The laminate of a T-joint can be split into several sublaminates:

- Base plate (skin)
- Stringer (frame)
- Bonding
- Cover

Figure 3.1: T-Joint Lay-Up

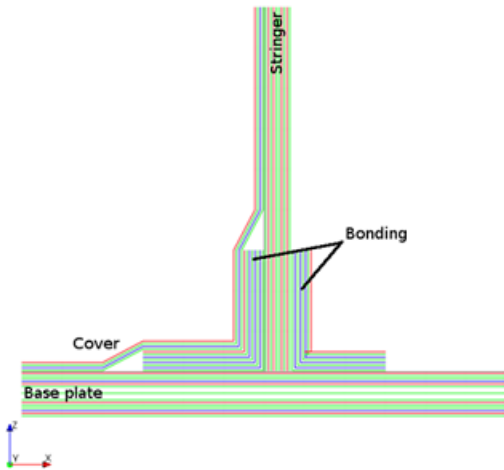

The laminate is modeled by defining different Oriented Selection Sets for the different regions. The modeling plies are then associated with the OSS and their order defines the stacking sequence of the laminate.

The first OSS is defined for the base. The offset direction of this OSS shows from top to bottom as shown in [Figure 3.2: OSS for the Base Plate \(p. 262\)](#).

Figure 3.2: OSS for the Base Plate

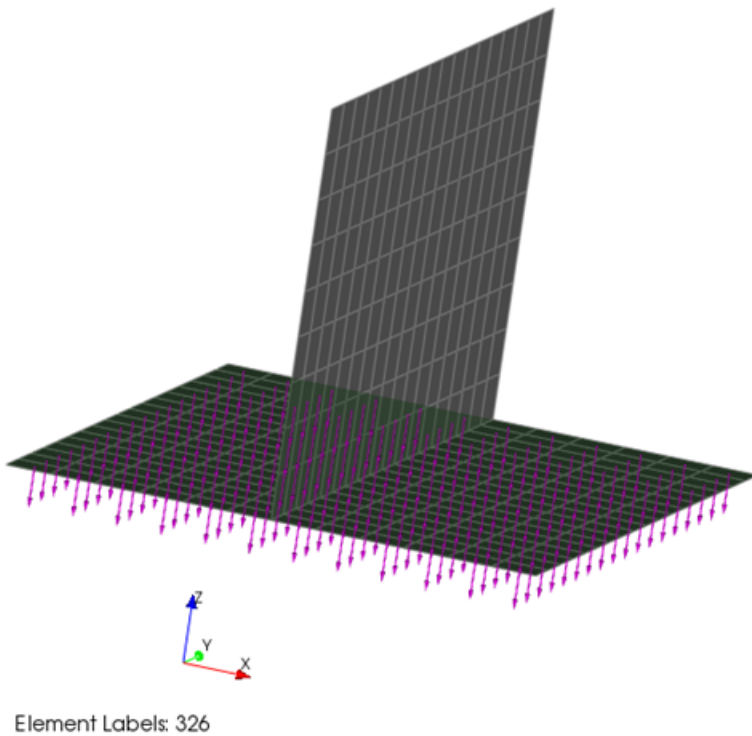

The OSS of the stringer has an orientation parallel to the global X-direction as shown in [Figure 3.3: OSS for the Stringer \(p. 263\)](#).

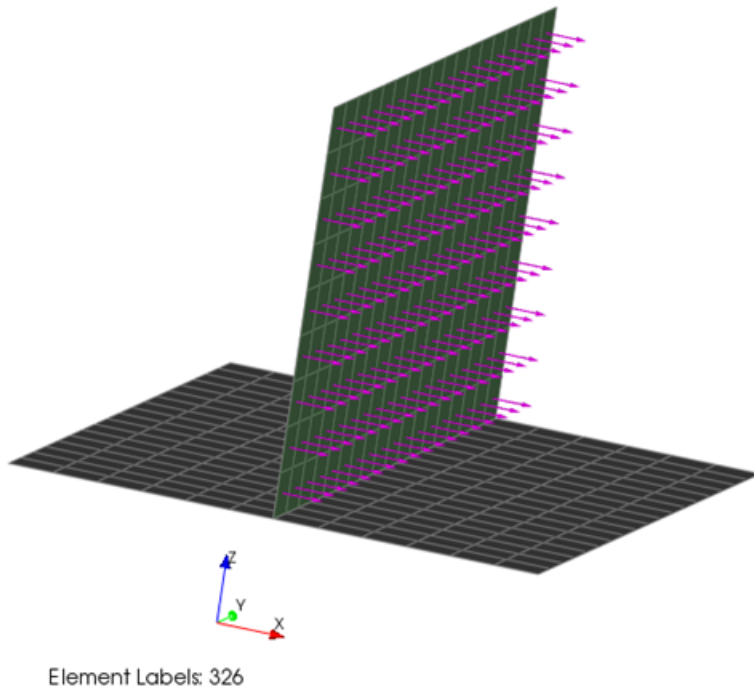
Figure 3.3: OSS for the Stringer

The OSS feature allows you to define several offset directions for one element: OSS can overlap and can have different orientations. This functionality is used to define the offset direction for the bonding layers as shown in [Figure 3.4: OSS for Bonding Plies](#) (p. 263). The offset direction of the base plate is different if compared with [Figure 3.2: OSS for the Base Plate](#) (p. 262).

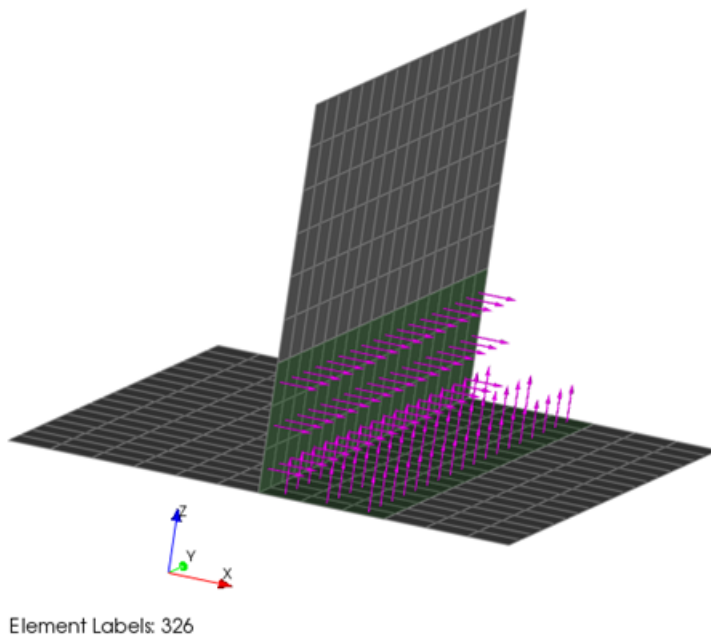
Figure 3.4: OSS for Bonding Plies

In addition, the OSS feature allows you to define the reference directions for complex shapes (twisted surfaces, right angles). The reference direction is computed from one or several reference coordinate systems (CSYS) as shown in [Figure 3.5: Reference Direction \(p. 264\)](#). In this case two CSYS are selected.

Figure 3.5: Reference Direction

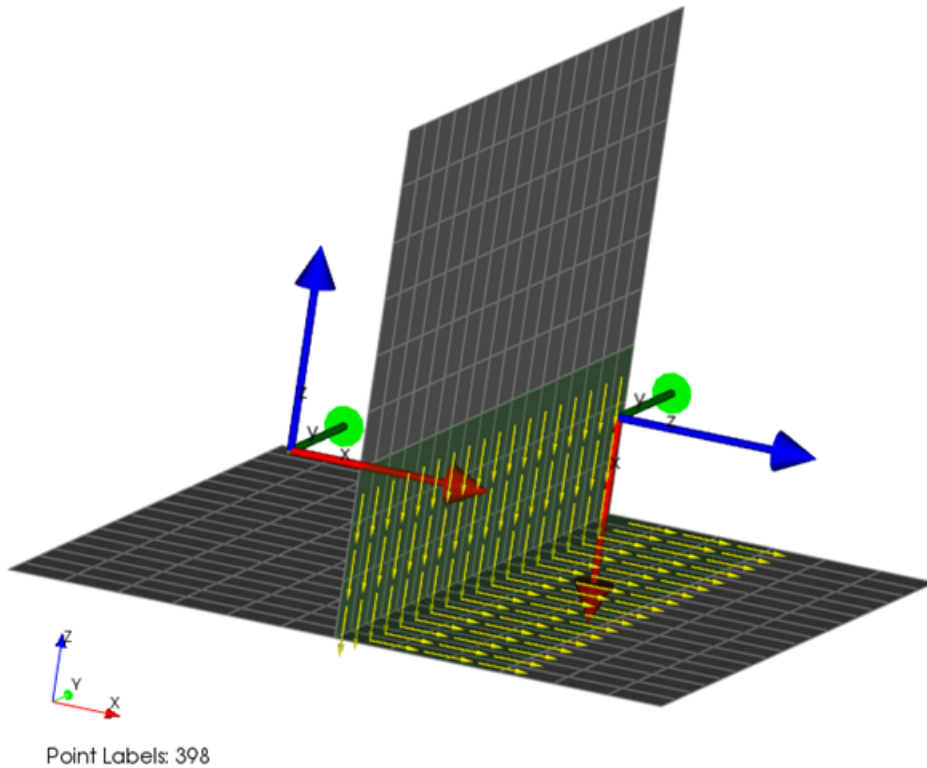

After all the necessary OSS are defined, define the Modeling Plies in the same order as the structure is produced later. First, the base lay-up is defined using the OSS of the base plate.

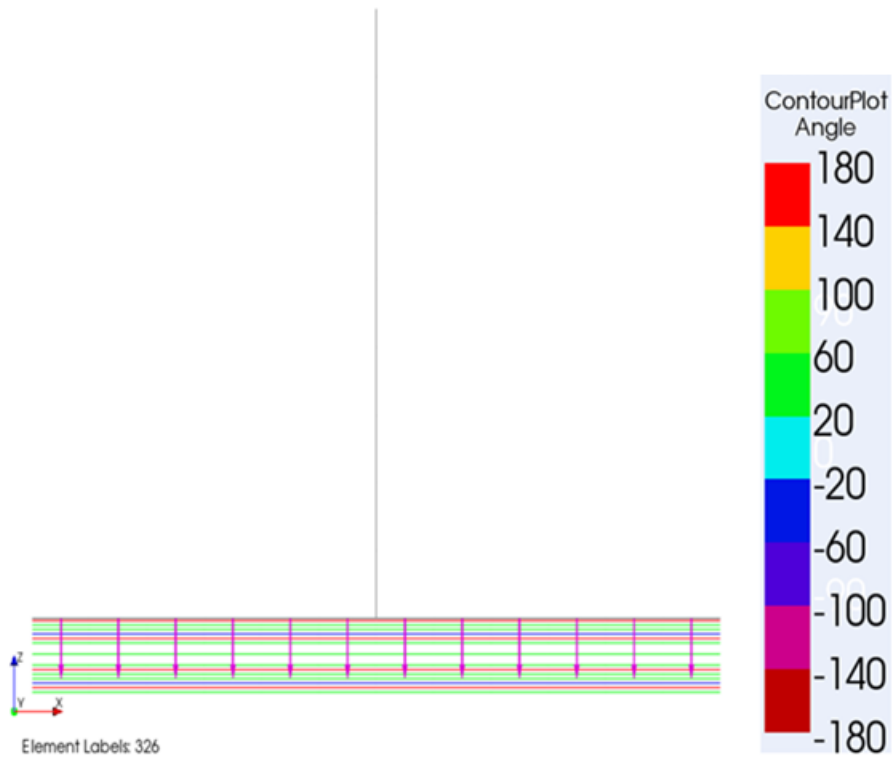
Figure 3.6: Laminate of the Base Plate

The next plies are added to the stringer.

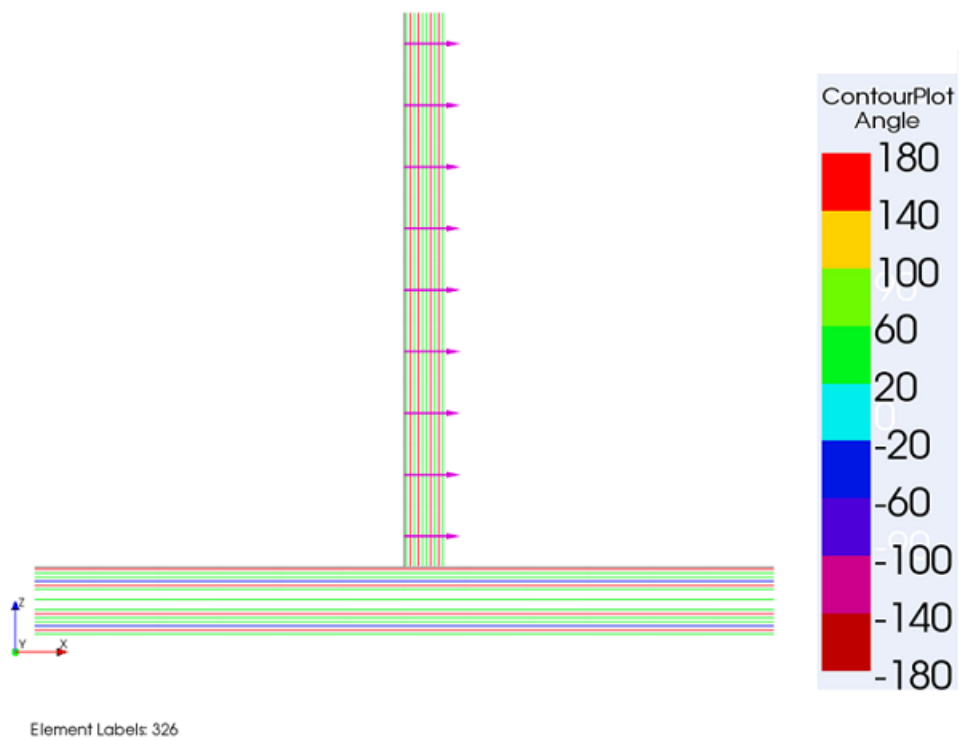
Figure 3.7: Laminate of the Base Plate and Stringer

It is important to define the base plate and stringer laminate before the bonding plies are defined because the order is responsible for the final offset. As shown in [Figure 3.8: First Bonding Laminate \(p. 266\)](#), the bonding layers are applied to the top of the base plate and onto the plies of the stringer.

Figure 3.8: First Bonding Laminate

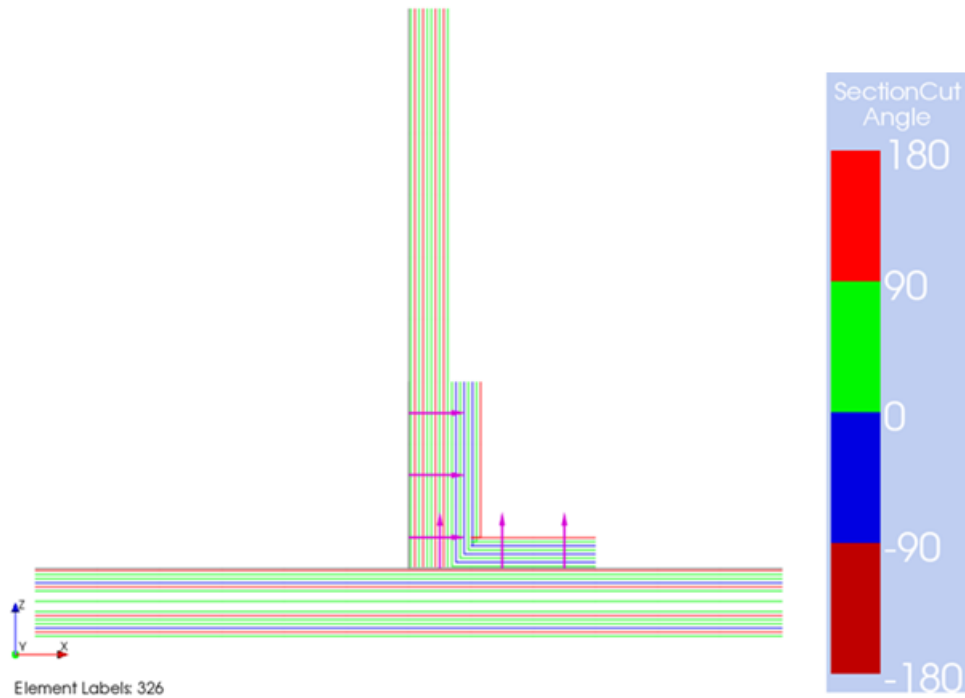

On the other side, the second bonding laminate is offset to the top (base plate) and to the left (stringer).

Figure 3.9: Second Bonding Laminate

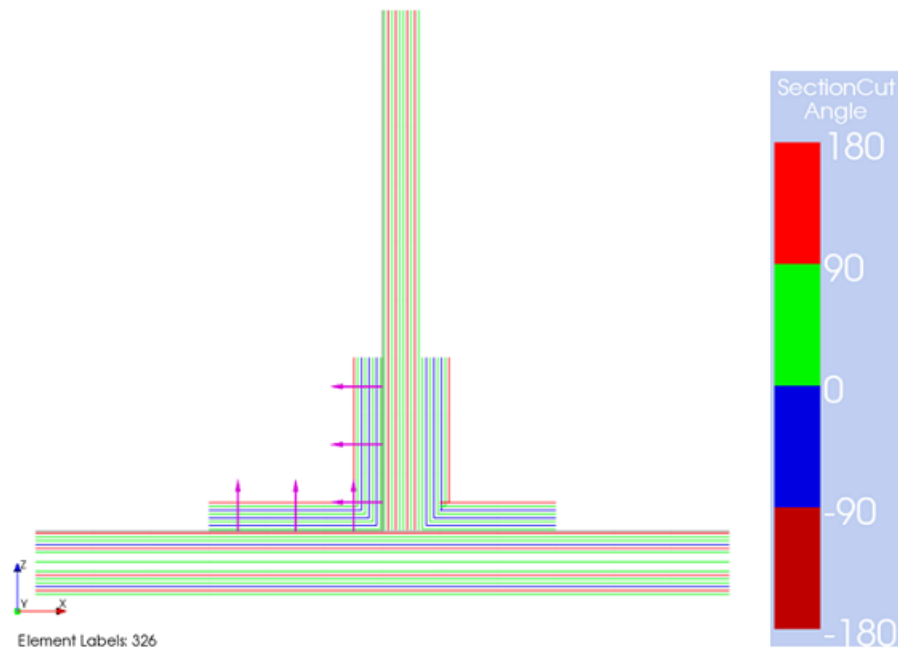

Cover plies complete the lay-up definition of the T-joint. [Figure 3.10: Cover Plies \(p. 267\)](#) shows that ACP can also handle Drop-Offs.

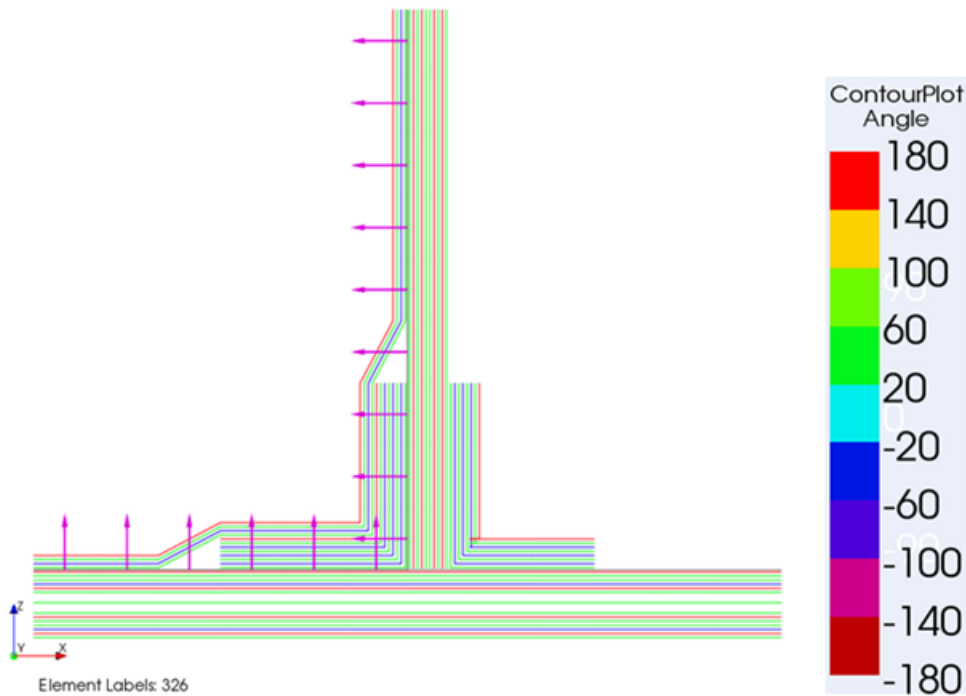
Figure 3.10: Cover Plies

3.2. Local Reinforcements

Regions with cut-outs, holes or load introduction elements are normally highly stressed and require local reinforcements to prevent failure. ACP offers different ways to define local patches. **Selection Rules** can be used to apply reinforcements to selected areas of the structure's geometry. The shape of a reinforcing ply is defined by the intersection of an Oriented Selection Set and the selected Selection Rules.

The examples [Tutorial 3](#) and [Tutorial 4](#) use Parallel Selection Rule and Tube Selection Rule to define patches. [Tutorial 4](#) describes how a Tube Selection Rule can be defined to add a ply following an edge. The procedure involves these steps:

1. Define an **Edge Set** from the boundaries of an **Element Set**.
2. Create a **Tube Selection Rule** along the defined **Edge Set** with a certain inner and outer radius.

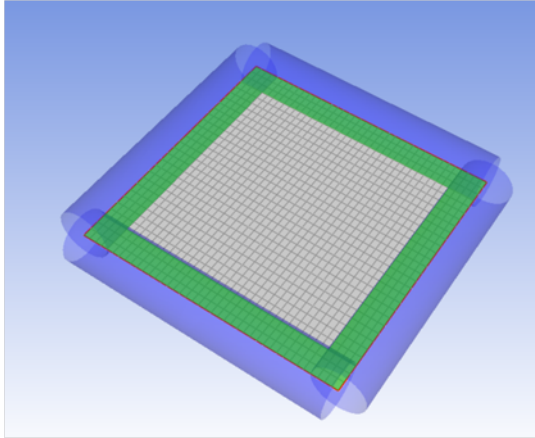
Figure 3.11: Tube Selection Rule

3. Create a new ply and configure the **Selection Rules** in the **Rule** tab of the **Modeling Ply Properties** dialog.

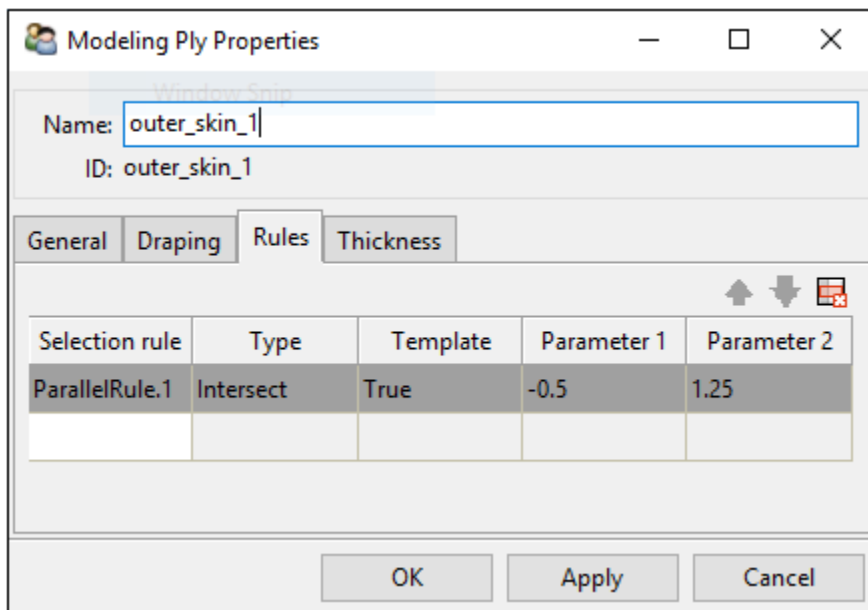
Figure 3.12: Rules Tab of the Modeling Ply Property Dialog

The selection rule parameters can be modified for each **Modeling Ply**. This allows you to work with one **Selection Rule** to define the staggering of a laminate. You can activate a template and set the new parameters. The final result can be double-checked with **Section Cuts** or a thickness contour plot as shown in the figure below.

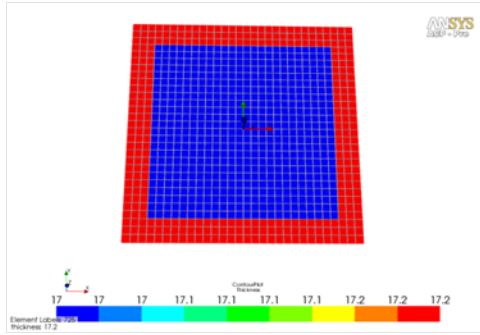
Figure 3.13: Resulting Local Reinforcements

Selection Rules can also be combined with **Oriented Selection Sets** and other **Selection Rule** types like **Parallel**, **Spherical**, or **Cylindrical** are also implemented in ACP. Any combination of these selection rules allows you to create plies with complex shapes.

3.3. Ply Tapering and Staggering

Ply tapering and staggering can be quickly defined within ACP. Several examples are shown below.

3.3.1. Ply Tapering

Core plies are generally much thicker than regular or woven plies. This means that core edges must be tapered for structural and manufacturing reasons. When a taper is applied to an edge of a ply in ACP and the corresponding thicknesses are evaluated and mapped automatically onto the finite elements.

3.3.1.1. Edge Tapering

This section gives an overview of how the edge tapering feature works. The **Taper Edges** option can be applied to [modeling plies](#) (p. 146). Its definition requires a constant taper angle along an edge set. Optionally, a taper offset can be specified. Based on this definition, a virtual taper plane is evaluated to taper the thickness of plies. The effective tapering or thickness distribution over the taper is further dependent on the resolution of the mesh.

[Figure 3.14: Simple Edge Tapering](#) (p. 270) shows a schematic of a simple edge tapering. An Edge Set runs along the side of a square of elements. Ply tapering is evaluated at each element along the edge set. The taper edge offset specifies the normal (thus out-of-plane) distance from each element adjacent to the element set. This offset forms a plane parallel to the underlying element. The taper angle specifies the angle between this offset plane and the resulting taper plane. In the figure, the resulting taper plane is the same for the whole edge set. The resulting taper planes are oriented differently if the Edge Set follows a curved path. The offset direction is set to be positive in the orientation direction of the oriented selection set of the modeling ply. Depending on the mesh and application, it may have to be specified as a negative value.

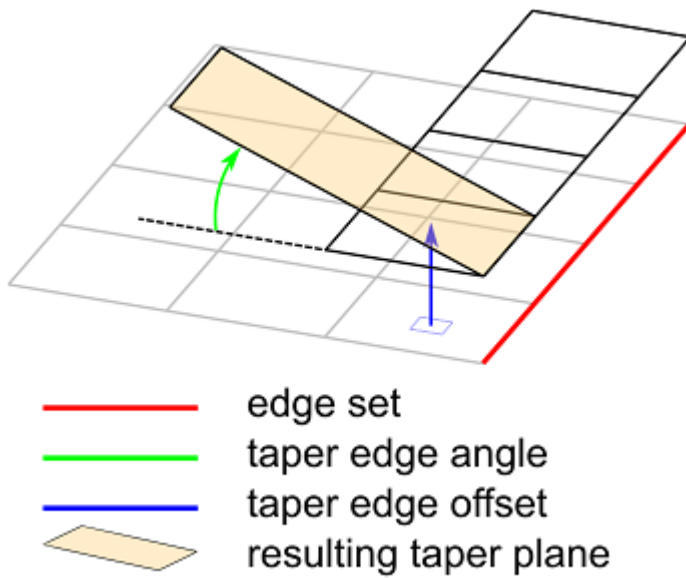
Figure 3.14: Simple Edge Tapering

3.3.1.2. Tapered Core

The [Tutorial 3](#) example uses a tapered core. Open the model and check the **Modeling Ply** `core_bwl` in the **Modeling Group** `Hull1`. In the **Thickness** tab of the properties dialog a taper angle of 15 degrees is defined for the edge `edgeset . 2`. A **Section Cut** or thickness contour plot illustrates the final result as shown in [Figure 3.15: Tapered Edge](#) (p. 270).

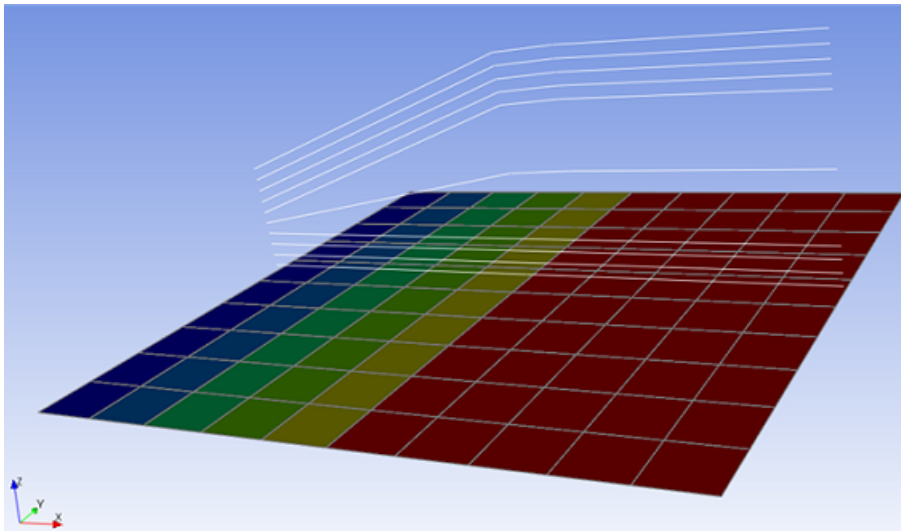
Figure 3.15: Tapered Edge

3.3.1.3. Tapered Edges

In [Tutorial 4](#), a Ply Tapering is defined along 2 edges. The procedure involves these steps:

1. Define an **Edge Set**. In this case, the **Edge Set** is defined through a **Named Selection** in Mechanical.
2. Open the **Thickness** tab in the **Modeling Ply Properties** dialog.

Figure 3.16: Tapering in Ply Definition

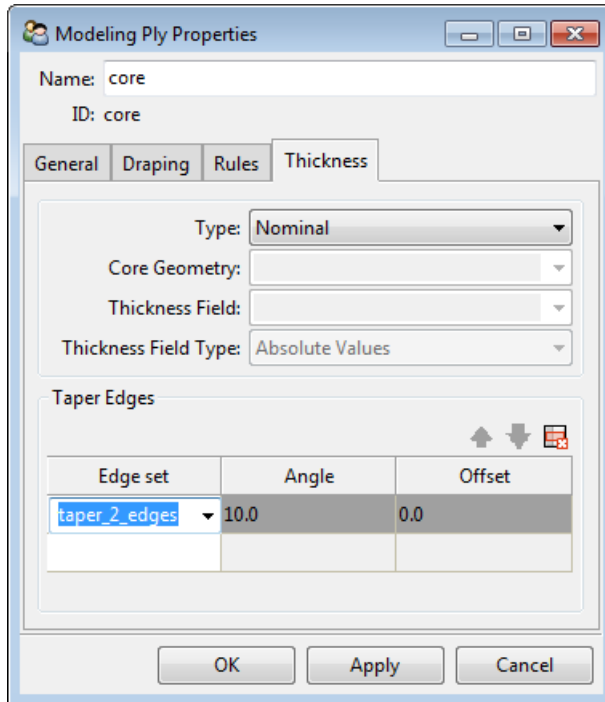

3. Select the edge and define the taper angle.

Figure 3.17: Thickness Distribution After Core Tapering

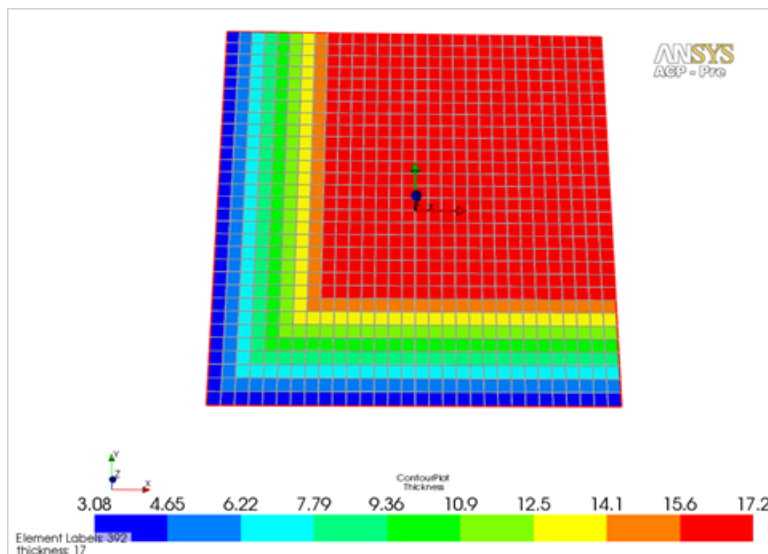

3.3.1.4. Tapering of Multiple Plies

The **Taper Edges** option for **Modeling Plies** is suitable for defining individual taper angles for specific modeling ply. Its intended purpose is for use with a single tapered ply, such as a core, however it can be used for tapering multiple plies. If the **Modeling Ply** tapering option is used for multiple layers the taper angle is applied to each **Modeling Ply** and the vertical ply thickness distribution is superimposed. In such a case, the total taper angle of the lay-up is generally higher than the individual taper angles. The total taper angle scales non-linearly with the number of plies and their thicknesses. Furthermore, the taper size is dependent on the size of the mesh. For this reason, care should be taken when using the **Taper Edges** option for multiple plies. When modeling a composite with a defined total taper angle a **Selection Rule** definition may be more suitable. The trailing edge of an airfoil blade is an example for such an application.

The example below shows the effects of superposing multiple modeling plies that have the same taper angle. The middle column shows a lay-up schematic while the right column displays the corresponding representation of a section cut in ACP. The superposition of two different ply thicknesses results in two taper angles of which one is steeper than the nominal angle.

Figure 3.18: Superposition of Modeling Plies with Identical Taper Angles. Schematic (Middle) and Section View Illustration (Right)

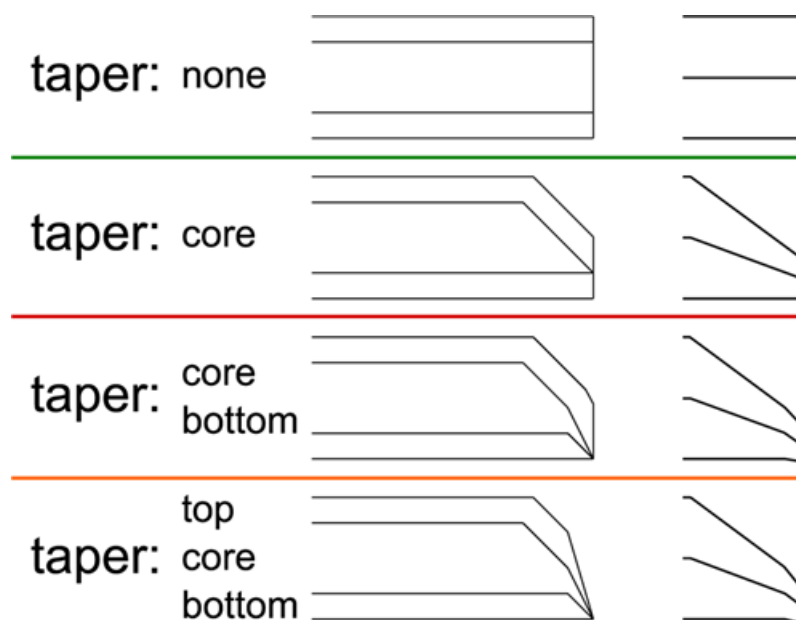

3.3.2. Ply Staggering

Cutoff Selection Rule

A **Cutoff Selection Rule** is used to cut plies and is suitable to define a ply staggering. This feature is not limited to an edge because the staggering is derived from a **CAD Geometry**. The intersection between the ply and geometry defines where the plies are cut. The ply offsets are taken into consideration. This allows you to define a laminate where the total thickness follows a 3D shape.

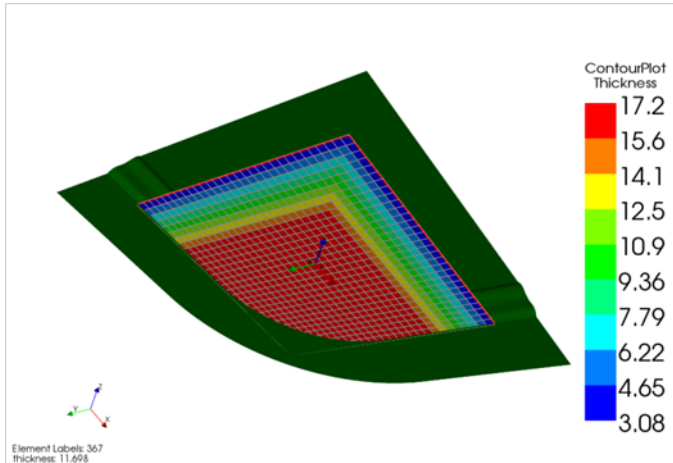
Figure 3.19: Thickness Distribution of a Laminate with a Cutoff Selection Rule

Template Selection Rule

The template selection rule feature of the **Modeling Ply** allows you to use one **Selection Rule** to define plies of different extensions. You can redefine the parameters of a selection rule in the **Modeling Ply Properties** dialog. A wind turbine blade, for example, has hundreds of similar plies that only differ in their the axial extension. Such plies can be defined with one **Oriented Selection Set** and one **Parallel Selection Rule** and the use of template parameters. The template parameters are easily adjusted using the **Import from / Export to CSV file** feature in the context menu of the **Modeling Group**.

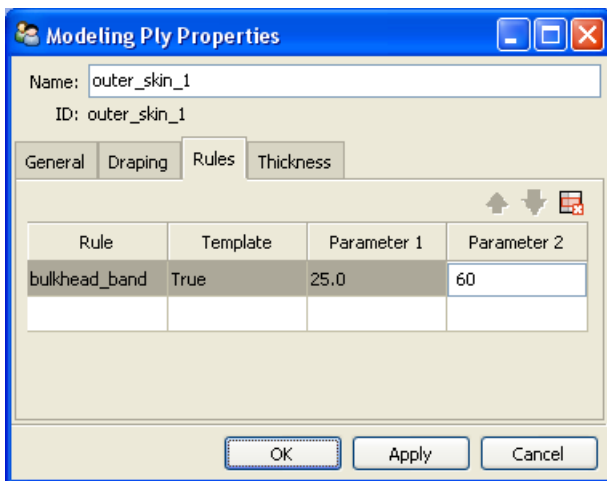
Figure 3.20: Template Selection Rule Definition

3.4. Variable Core Thickness

In many cases, the thickness of a sandwich panel is constant or single plies have a constant thickness. For structural efficiency, cores with variable thickness are used more often since CNC milling allows the production of core plies with complex shapes.

In ACP there are three different ways to define a laminate with variable thickness:

3.4.1. Solid CAD Geometry

3.4.2. Look-Up Table

3.4.3. Geometry Cut-Off Selection Rule

3.4.4. General Application

3.4.1. Solid CAD Geometry

An external core geometry can be used to define the variable core thickness. The 3D shape of the core is modeled in a CAD tool as a 3D solid or a closed shell. This **CAD Geometry** can be imported directly into ACP or via Workbench.

Figure 3.21: Imported Core Geometry

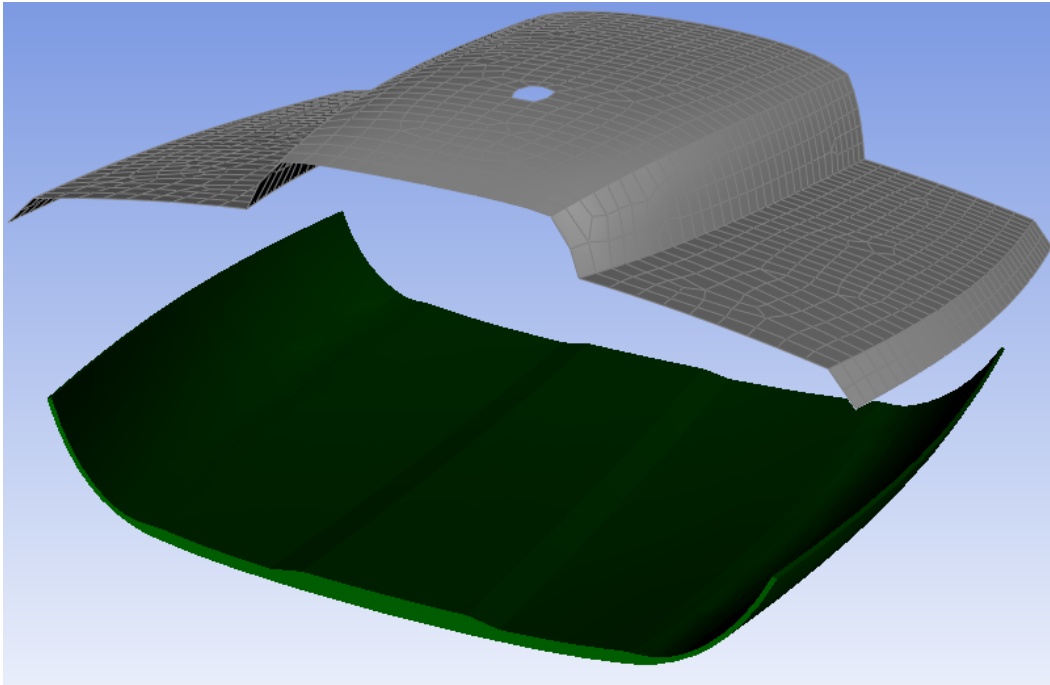

In the **Thickness** tab of the **Modeling Ply Properties** dialog, the thickness definition can be changed from **Nominal** to **From Geometry**. In this case, ACP samples through the geometry in the normal direction and evaluates the thickness of the core for each element. The original thickness defined in the **Fabric** definition becomes obsolete. This method is used in the [Tutorial 3](#) example..

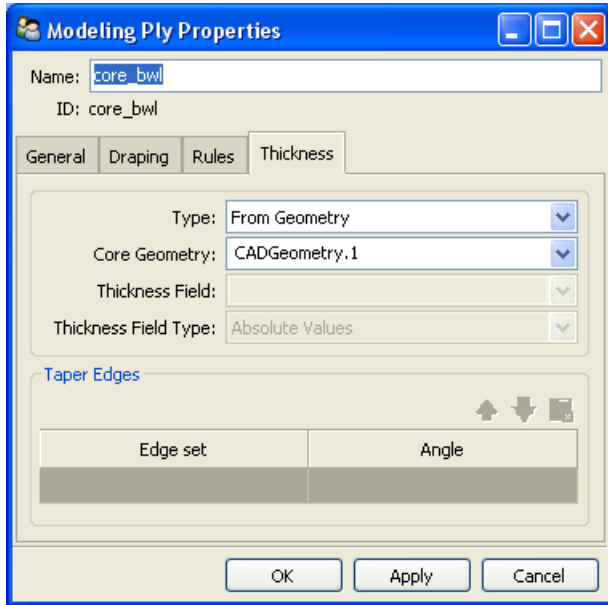
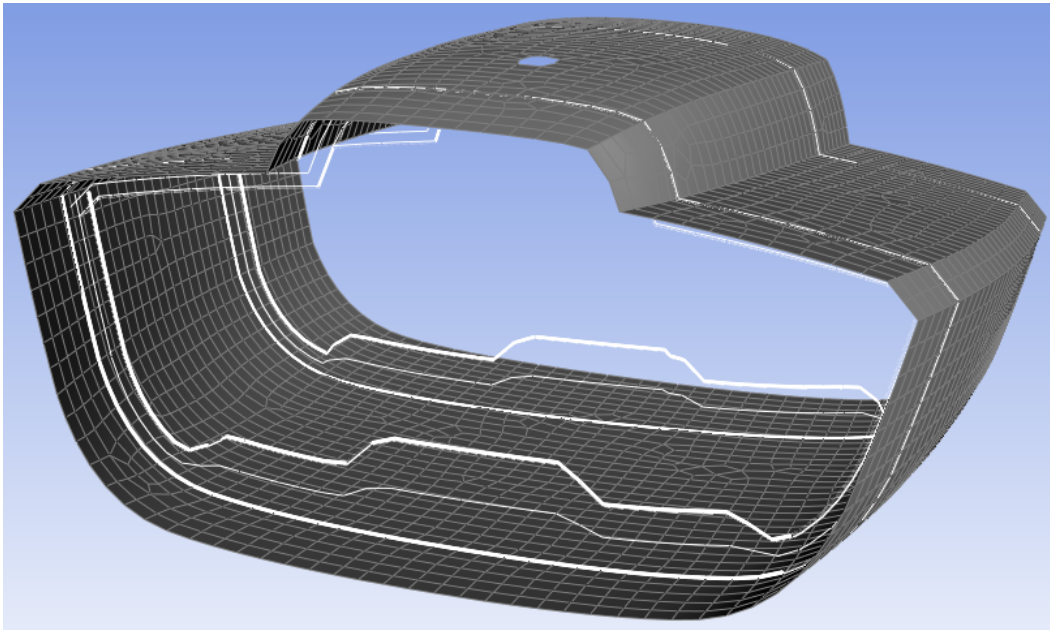
Figure 3.22: Modeling Ply Thickness Definition**Figure 3.23: Section with Variable Core Thickness**

3.4.2. Look-Up Table

The variable core thickness can also be defined with a **Look-Up Table**. A **Look-Up Table** is used to define a data field or tabular values. Thicknesses, angles and directions can be defined in a **Look-Up Table** and the 3D mapping function of ACP inter- or extrapolates the values for each element. You define the thickness of the ply material for certain support points. The figure below shows a list of different angles and thicknesses for selected data points.

Figure 3.24: Table Definition

i	Location.x	Location.y	Location.z	th
0	-1000.000000	0.000000	0.000000	20.000000
1	0.000000	0.000000	0.000000	20.000000
2	0.000000	0.000000	1500.000000	20.000000
3	-1000.000000	2500.000000	0.000000	20.000000
4	0.000000	2500.000000	0.000000	20.000000
5	0.000000	2500.000000	1500.000000	20.000000
6	0.000000	138.888900	1500.000000	20.000000
7	0.000000	138.888900	1333.333300	20.000000
8	0.000000	0.000000	1333.333300	20.000000
9	0.000000	69.444400	1416.666700	1.000000

Following on, the corresponding tabular field can be selected in the **Thickness** tab of the **Modeling Ply Properties** dialog.

Figure 3.25: Thickness Definition Through Tabular Values

Edge set	Angle	Offset
EdgeSet.1	15.0	0.0

The final result can be investigated with **Section Cuts** or a thickness contour plot as per usual.

3.4.3. Geometry Cut-Off Selection Rule

Another way of achieving a variable core thickness is to use a **Cut-Off Selection Rule**. Even if the cutting operation only applies to a core layer, it is dependent on the entire lay-up. If the thickness of the bottom laminate is changed, the thickness of the core is cutoff at a different height. In this way, a laminate thickness limit can be set. This can be a very useful in places where the laminate thickness is limited, near a trailing edge of a blade for example.

Figure 3.26: Section Cut and Thickness Contour Plot

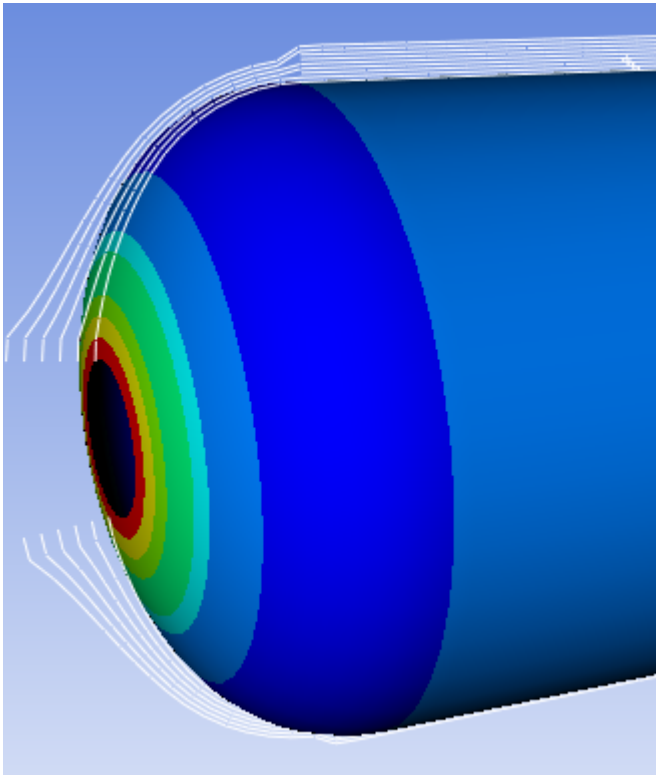

The core thickness can be set to be cut in different ways depending on the **Ply Tapering** option of the **Selection Rule**. It can either follow the exact intersection with the **CAD Geometry** or can be cut off to two discrete size - its nominal thickness or no thickness at all.

The **Cut-Off Selection Rule** has to be used with precaution as any modification of the underlying plies might modify the core.

An example of a **Cut-Off Selection Rule** can be found in [Tutorial 4](#).

Figure 3.27: Imported Cut-Off Geometry

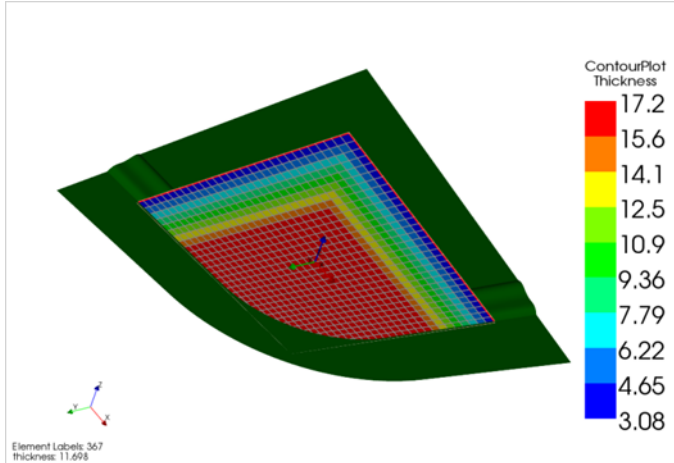
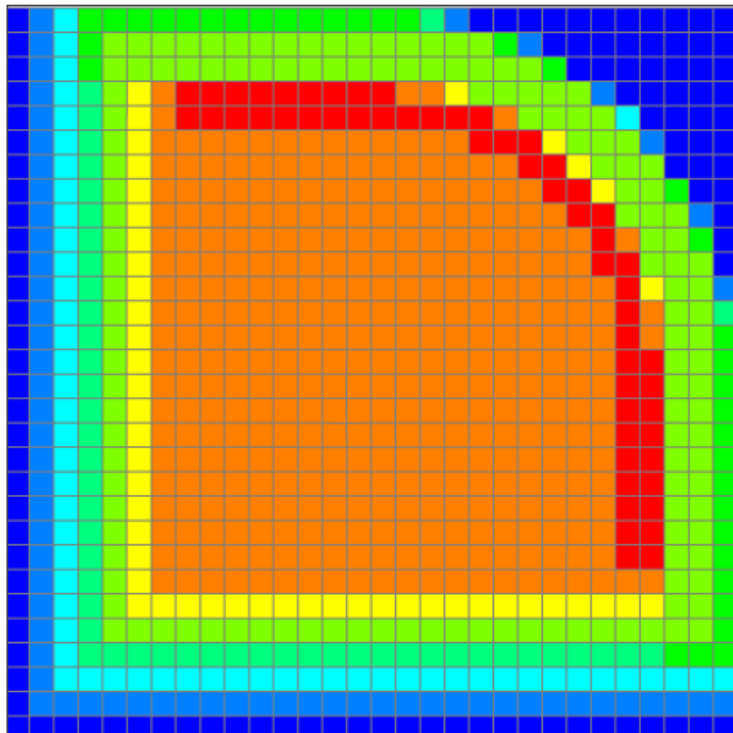

Figure 3.28: Resulting Thickness Distribution (Ply Tapering Activated)



3.4.4. General Application

The described features can also be used in combination with regular or woven materials and are not restricted to core materials. The selection of the method is often derived from the manufacturing process. Tabular values can be used for a winding process and CAD geometries for a CNC milling process. A [Cut-Off Selection Rule](#) (p. 277) is often used in regions of sharp tapered edges (trailing edge of a wind turbine blade).

3.5. Draping

The ply application (draping) on doubly curved surfaces changes the theoretical fiber orientations. In many cases the effect is small and can be neglected. On the other side it is important to know how big this effect can be and if it has to be considered. ACP allows you to evaluate the draped fiber directions. These angles can be visualized and are considered in all analyses, resulting in more accurate evaluations. The draping is evaluated on the **Production Ply** level. In addition the draping algorithm of ACP evaluates the flatwrap of the **Production Plies** which can be exported for manufacturing purposes.

Figure 3.29: Flatwrap (Boundary)

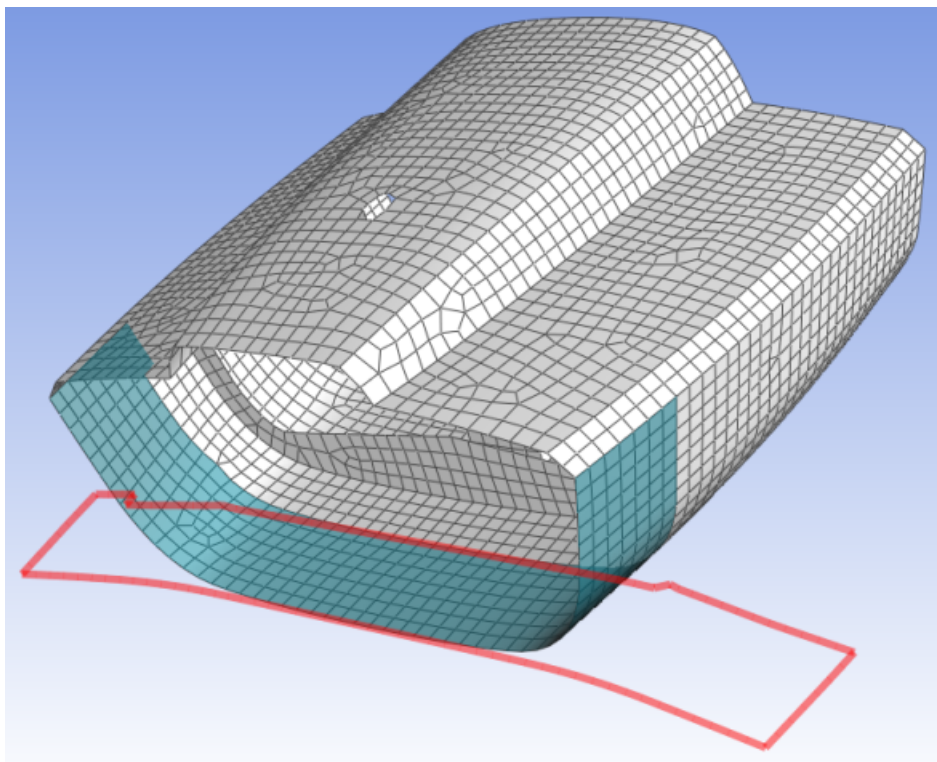

3.5.1. Internal Draping Algorithm of ACP

The draping algorithm is described in [Draping Simulation in the Composites Theory Reference](#).

Draping Method Definition

The draping effect depends highly on the manufacturing process. Process-relevant values can be defined in the ACP draping algorithm.

Seed Point

The **Seed Point** is the starting point where the ply is laid into the mold. At this location the fiber direction is unchanged and the draped fiber direction is equal to the theoretical one. The **Seed Point** can have a big influence on the final result of the draped fiber angles. Assuming a half sphere and a **Seed Point** located on the pole, the maximum draped fiber angle is much smaller than the same evaluation with a **Seed Point** on the equator. The **Seed Point** corresponds to the first element of the draping mesh (left representation in [Draping Scheme in the Composites Theory Reference](#)).

Draping Direction

After the first point is applied on the mold, the **Draping Direction** defines along which route the ply is laid into the mold. The draping algorithm first walks along the **Draping Direction**, then orthogonal and finally proceeds with the 45-degree zones. [Draping Scheme in the Composites Theory Reference](#) shows the scheme in which the ply is applied.

Draping Mesh

The draping algorithm minimizes the shear energy dissipation where an internal **Draping Mesh** is used for the evaluation. This mesh is independent from the structural mesh and has its own size. Analog to the structural mesh, the optimal **Draping Mesh** size is established by balancing the precision of the draping evaluation and the computational cost.

In the case of an incomplete draping, select another **Seed Point**, define a different **Draping Direction** and/or change the **Draping Mesh** size. The draping mesh is built as shown in [Draping Scheme in the Composites Theory Reference](#).

Figure 3.30: Draping Mesh with Shear Energy

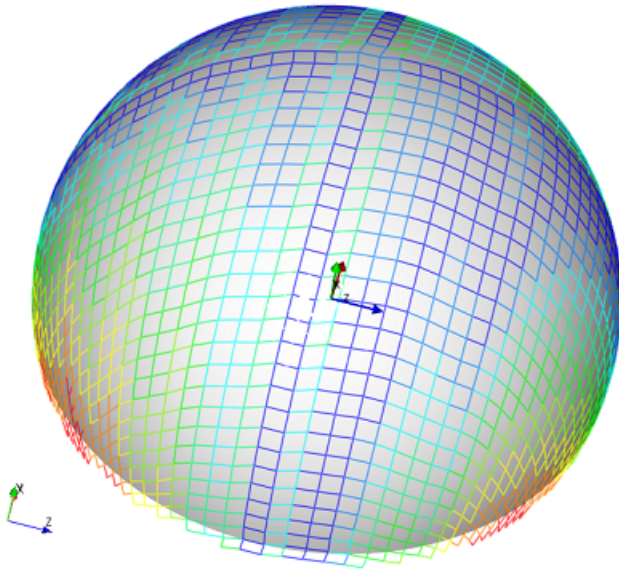

Draping Definition on OSS Level

The draping can be activated in the **Draping** tab of the **Oriented Selection Set Properties** dialog.

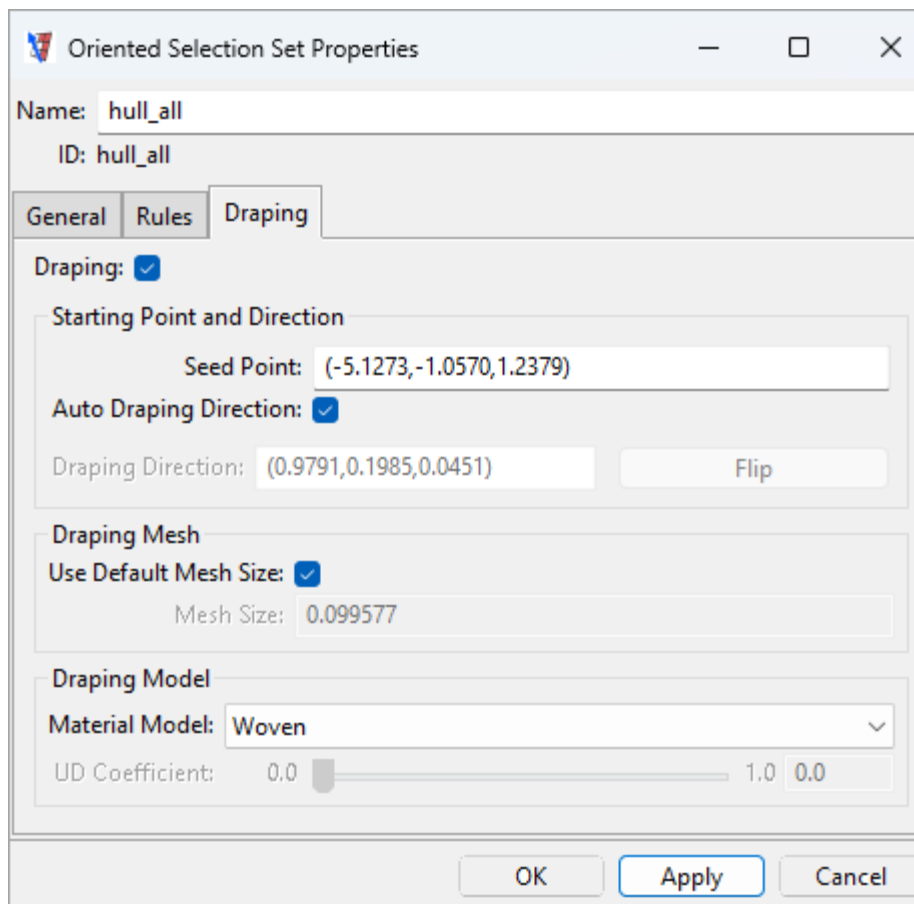
Figure 3.31: Draping Definition in OSS

If draping is activated on the OSS level, the Reference Direction of the OSS is adjusted and all associated modeling plies use this draped reference direction. If the Modeling Ply also has an active draping definition, then an independent draping simulation is started for the modeling ply.

Draping Definition on Modeling Ply Level

Just like OSS, draping can be activated on the **Modeling Ply** level. To activate the draping you toggle the **Draping** check box and define a **Seed Point**. By default, the **Mesh Size** and **Draping Direction** are evaluated automatically.

By default, during the draping simulation the draping mesh is laid on the reference surface of the model independently of the lay-up thickness. If the model property **Use Draping Offset Correction** is enabled, the draping mesh follows the bottom offset (relative to the reference surface orientation) of the selected ply, thus taking into account the lay-up thickness.

An additional feature, **Thickness Correction**, is implemented in the **Internal Draping** algorithm. Due to the shear deformation, the fiber direction and thickness of the ply change. This change can also be considered by activating the **Thickness Correction** option.

3.5.2. User-Defined Draping

ACP can also handle user-defined draping results. The draped fiber directions can be imported as a **Look-Up Table** and used instead of **Internal Draping**.

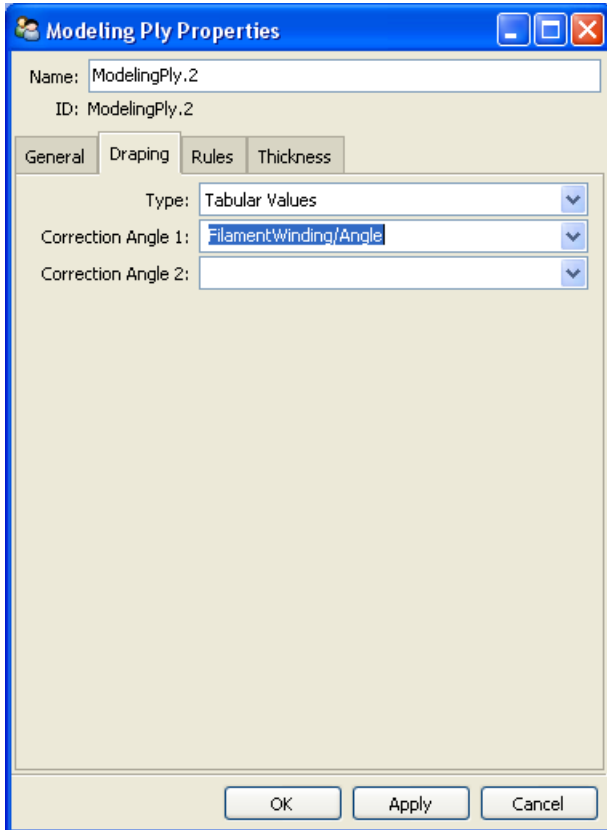
Figure 3.32: Tabular Values Definition of Draping

The first angle **Correction Angle 1** defines the correction of the material reference direction and is also considered in the analysis. The second value **Correction Angle 2** can be used to define the correction angle of the material 2 direction for woven materials. In ACP, the second correction is not considered in any evaluation and is just for information or third party products.

3.5.3. Visualization

The result of the draping evaluation can be visualized on the **Production Ply** and the **Analysis Ply** level. The flatwrap and the draping mesh can be visualized through the use of a **Draping Mesh Plot** (p. 222). The contour plot of the draping shows the average shear (distortion) angle of each element (in degree). Zero means no shear deformation. Depending on the Scene configuration the flatwrap is also available in the **Ply Book** (p. 234). In addition the **Production Ply** functionality allows you to export the flatwrap as a `.dxf` file.

The last result of the draping are the draped fiber directions which are considered in the analysis. These directions can be visualized with the **Show Draped Fiber Directions** button. This visualization combined with **Show Fiber Directions** highlights the influence of the draping.

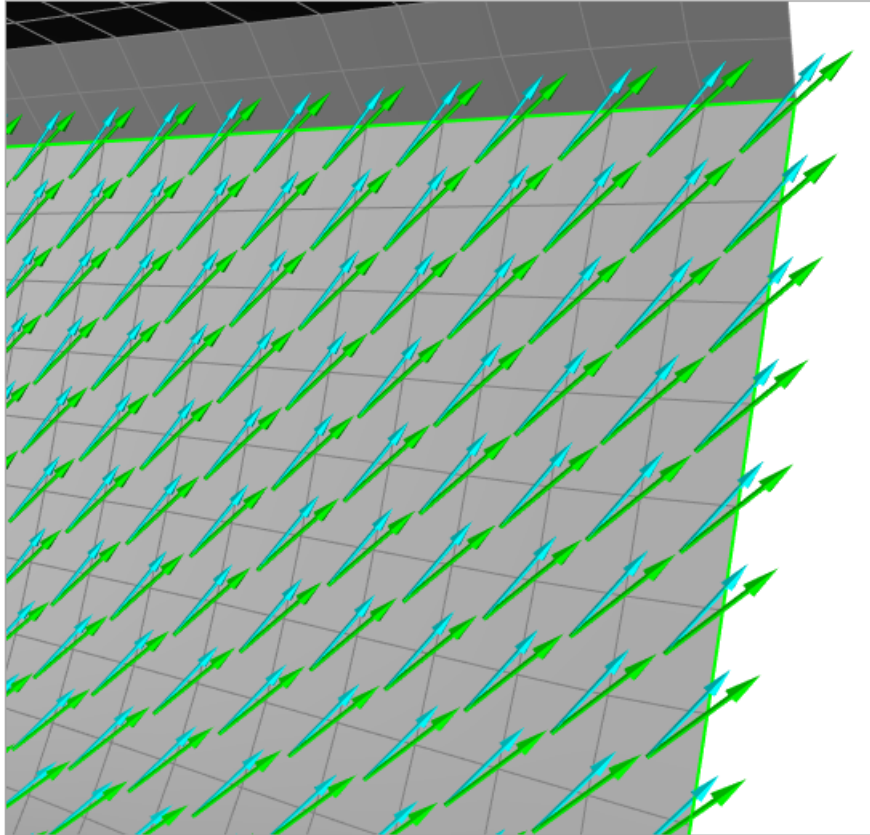
Figure 3.33: Fiber and Draped Fiber Directions

3.6. Guide to Solid Modeling

This section describes when and how to work with the [Solid Model \(p. 283\)](#) feature in ACP (Pre). In this context we are talking about the solid model extrusion and not the lay-up mapping feature within the Imported Solid Model.

In the case of thick composites, the layered shell theory can cause significant errors in the obtained results. In some cases it is necessary to work with 3D models (solid models). ACP has the advanced features to generate layered solid models based on the shell lay-up definitions. Based on the shell mesh and the ACP composite definitions, ACP generates layered solid elements representing one-to-one the composite part. Drop-Offs, staggering and tapering are also considered. In addition the solid model extrusion allows to define extrusion directions, boundary curves, and cut-outs. Finally, virtual cracks (fracture analysis) and contacts between plies can be modeled by [Interface Layers \(p. 151\)](#).

In general we recommend working with the "standard" Solid Model because the extrusion approach allows you to generate a one-to-one solid model. If this is not feasible, then the lay-up mapping approach within the [Imported Solid Model \(p. 208\)](#) is a great alternative. Modeling full cross-section composites such as composite springs or turbine blades, for instance. Example analyses for both approaches are available: [Composite Solid Model \(p. 314\)](#) and [Analysis of a Mapped Composite Solid Model \(p. 326\)](#).

The following sections give a brief guide to Solid Modeling:

[3.6.1. When to Use a Solid Model](#)

[3.6.2. How to Use the Solid Model Feature](#)

3.6.3. Principles of Solid Model Generation

3.6.4. Drop-Off and Cut-Off Elements

3.6.5. Workflow

3.6.6. Practical Tips

3.6.7. Known Limitations

3.6.1. When to Use a Solid Model

From an analysis point of view, the choice between a shell or solid element analysis models largely depends on the structure and the type of structural investigation.

Solid models are inherently larger and computationally more expensive than shell models. It is therefore wise to start an analysis with a shell model before moving on to a solid model. It provides a basis for comparison but it is also a good check on whether the model is solvable.

Typically, a solid model describes the behavior of a structure more precisely when its out-of-plane response becomes significant. ACP has the unique feature of representing the 3D stress state for a shell model. Shell model stress behavior can therefore be taken as a first indication of the 3D stress state. If the out-of-plane stresses are significant then it may be worthwhile analyzing the structure as a solid element model.

The following list shows cases where a solid element model can be used. The solid modeling feature is not limited to these examples.

- Analysis of thick structures
- Investigation into 3D stresses (high element resolution necessary)
- Investigation into debonding
- Investigation into edge effects
- Buckling analysis of sandwich structures

There are no hard rules on this matter. It remains entirely the choice of the designer when to use a solid model in addition to or instead of a shell model.

3.6.2. How to Use the Solid Model Feature

The intention of the solid model feature is to generate analysis models for structures that are built in one piece.

The feature itself makes no distinction between generating solid element models that are analyzed in isolation or ones that are analyzed in combination with other components. There is however a distinct difference in how the analysis of a solid element model of multiple components can be approached. The components of an assembly can either be extruded individually or extruded as one assembly. Both approaches are possible within ACP yet they both have advantages and limitations.

The recommended approach is to generate individual components and connect them using contacts in a Workbench Analysis System. This follows the intention that Solid Models are only created for

components that are to be built in one piece. Additional connecting structures can be also fully modeled or dimensioned with the help of substitute model.

The other approach is the extrusion of an entire assembly in one solid model generation. This method is not only limited by the topological complexity of a geometry but also by a reduced stiffness at transitions as a result of Drop-Off elements. On the other hand, this approach offers the ability to model all connecting structures in full.

3.6.3. Principles of Solid Model Generation

The solid model feature requires a reference shell geometry and a composite definition to construct a solid element model.

Solid model settings control how the solid model is divided into elements in the thickness direction and how Drop- and Cut-Off elements are handled. The level of detail required in the solid model depends on how accurate certain features are to be modeled. This depends on the judgment of the designer.

The feature has additional ways to enhance the resulting solid model to be as detailed as necessary: ply staggering and tapering are transferred from the composite definitions. Extrusion Guides add more complex possibilities in shaping the model. The Snap-To functionality makes an alignment with an external CAD geometry possible. Arbitrary cut-outs or cut-offs can be created with Cut-Off Geometries. The Cut-Off operation is analogous to machining a composite part after curing.

Geometry operations (Extrusion Guides, Snap-To and Cut-Off geometries) help to shape a solid model into the desired shape. These operations are applied sequentially to the solid model. You should explore all possibilities of shaping the solid model first with the help of Extrusion Guides and Snap-To geometries before moving on to Cut-Off features. While Cut-Off geometries allow great freedom in shaping a solid model, they also introduce degenerated elements which are limited in representing a layered composite. For more information, see [Drop-Off and Cut-Off Elements \(p. 285\)](#).

Details of the solid model feature are explained in the [Usage Reference \(p. 61\)](#).

3.6.4. Drop-Off and Cut-Off Elements

Drop-Off and Cut-Off elements cannot store any layered information and therefore must be associated with a homogenous material.

Drop-Off elements are created when ply boundaries exist inside the part. When the plies come to an end, the solid model extrusion creates a Drop-Off element in the shape of a triangular prism. The Drop-Off Elements can be modeled with either the ply (or core) material, a different material such as resin, or as a void.

Cut-Off elements are created when a hexahedral element is diminished by a Cut-Off operation and decomposed into prism or tetrahedral elements. These elements can also be modeled with different homogenous materials.

The Cut-Off features offer great freedom in shaping a solid model. The trade-off when using the Cut-Off feature is that elements diminished by the cutting operation are decomposed into homogenous tetrahedral and prism elements. These elements cannot store any layered information and the post-processing results for Cut-Off regions must be interpreted with care.

Both Drop- and Cut-Off elements can cause steps in the structural stiffness, which may lead to stress peaks and higher IRFs. This affects the homogeneous elements as well as the layered elements in their proximity.

For information on the postprocessing of stresses and strains of homogeneous elements, see [Postprocessing of Drop-Off and Cut-Off Elements in the Mechanical User's Guide](#).

3.6.5. Workflow

A solid model is easily created alongside an existing shell model in Workbench. Once a solid model has been generated in ACP (Pre) it can be linked to new Analysis System. A single ACP (Pre) system can be used to create a shell and a solid model analysis. This workflow is shown below:

Figure 3.34: Analyzing a Solid Model Alongside a Shell Model

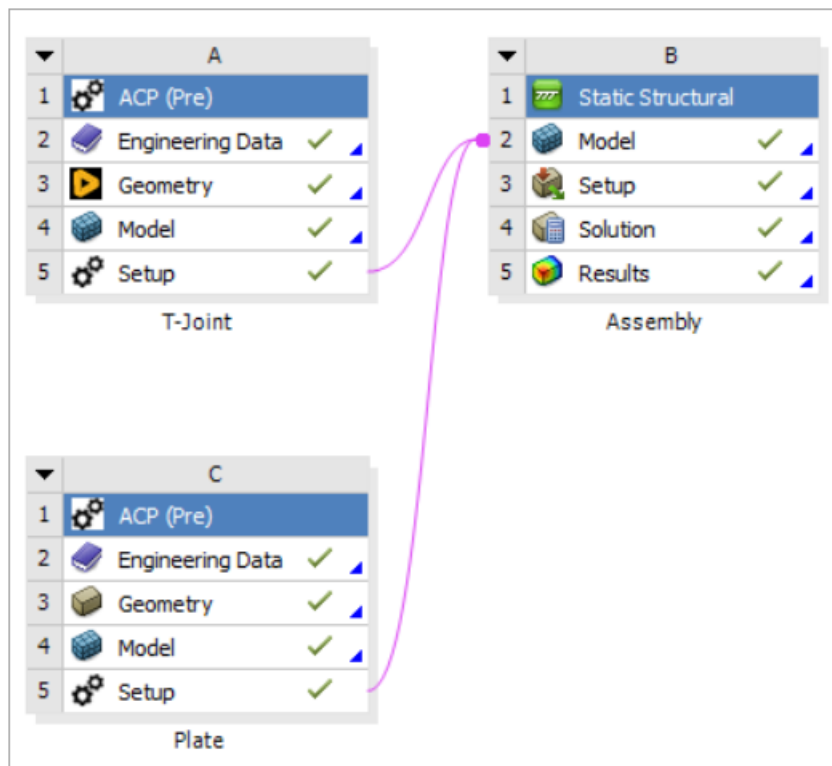

The analysis of an assembly requires multiple solid model components to be connected in a Workbench system. The components can be connected with contacts in Mechanical, for example. As a consequence, the connections can be modeled and analyzed in detail. The [Composite Failure Tool](#) in Mechanical permits the analysis of all composite parts at once or for a selected scope of interest.

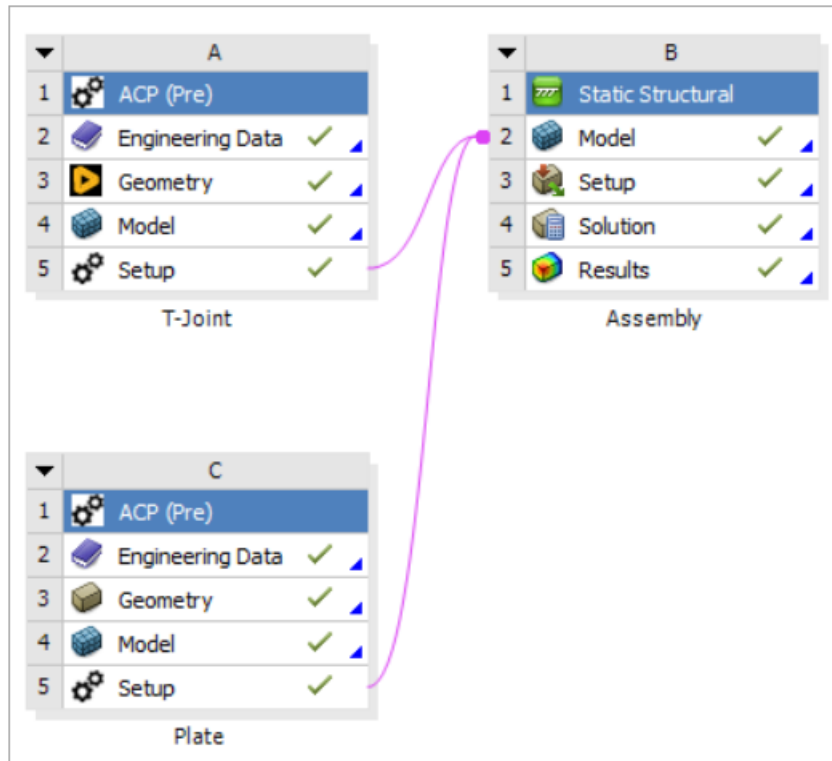
Figure 3.35: Solid Model Assembly Workflow

3.6.6. Practical Tips

The solid modeling process is generally more complicated than shell modeling is. The shape and mesh of a structure have a strong influence on the robustness of the solid modeling process. Generally speaking, the less complex the model the more robust the process. The challenges of composite modeling can vary greatly. Following composite design principles for structural concepts will aid the solid modeling process. Abrupt changes in shape and sharp edges are not advisable in composite design and also cause problems in composite modeling.

You can use Named Selections to define boundary conditions, contacts, and much more. Named Selections also contribute to making your model associative which automates the update process. For this reason Named Selections of the shell geometry are converted and maintained in the solid model workflow as shown in the figure below. An edge becomes a wall (edge_1 \Rightarrow EDGE_1_WALL) and a surface is converted into a bottom and top surface (face \Rightarrow FACE_BOT and FACE_TOP) in the solid of the downstream Mechanical system.

Figure 3.36: Conversion of the Named Selections in the Solid Model Workflow

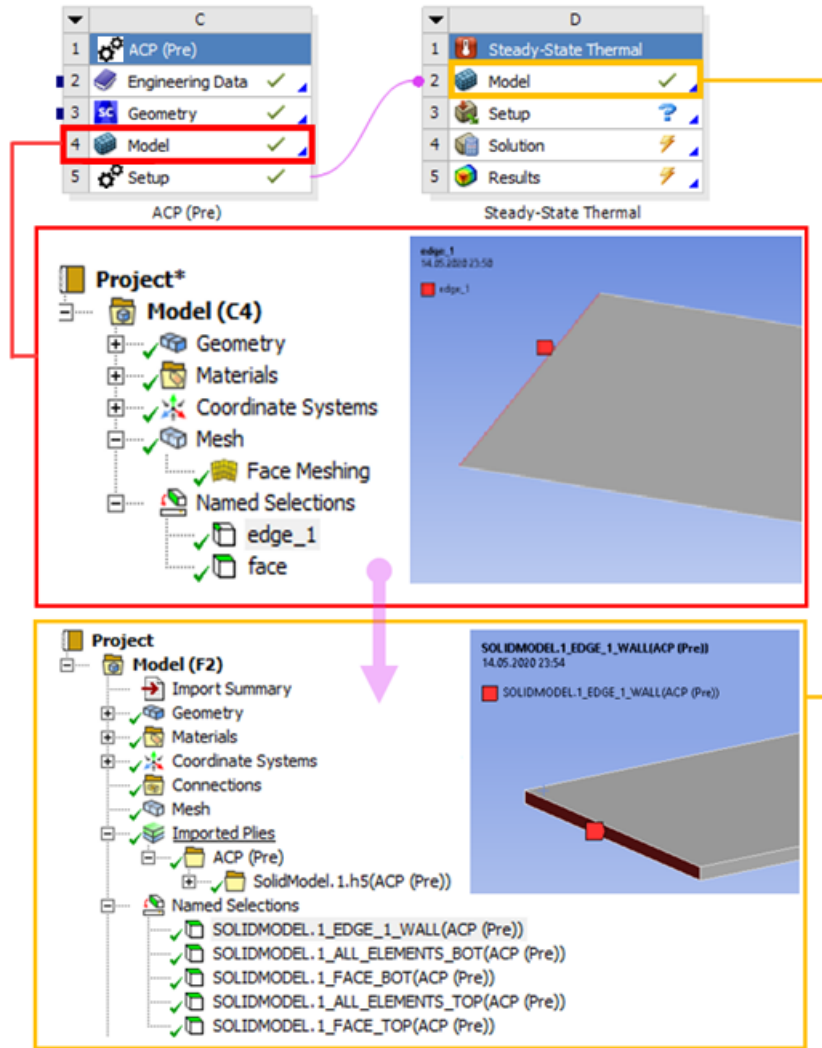

3.6.7. Known Limitations

Awareness of the limitation of solid modeling can help you build a better solid model. It is worth spending time thinking about aspects of your model such as mesh sizing, extrusion methods, and geometry operations. For example, it can often be more robust to extrude from the inside out.

This section gives an overview of the limitations of these advanced modeling features:

Mesh Extrusion

The solid model relies on the extrusion of a shell geometry mesh. As the extrusion directions and operations increase the solid model generation reaches a limit of how heavily a shell mesh can be distorted. If the topology of the structure is complex then the extrusion operations can result in ill-formed elements which are subsequently deleted in the element check.

Drop-Off Elements

There are transition regions where an edge of a solid model extrusion is reduced to a series of Drop-Off elements. This reduction in thickness will result in a local reduction in stiffness that should not be overlooked.

Cut-Off Elements

Cut-Off elements are decomposed into homogenous tetrahedral and prism elements. These elements can cause abrupt changes in the structural stiffness which may lead to higher stresses and IRFs. The results in the proximity of Cut-Off elements should be evaluated with care.

Connect Butt-Jointed Plies

The ability to connect adjacent plies is currently restricted to plies that appear sequentially in the same Modeling Group. Consequently, there is a certain arrangement where a ply drop-off cannot be evaded.

Solid Model Extrusion Offset

The solid model extrusion starts from a reference shell and the lay-up definition. An extrusion with an offset to the reference geometry is not possible.

Sampling Points, Section Cuts, and Sensors

Sampling points, Section Cuts, and Sensors give information about the lay-up as it was defined in the Modeling Ply Group. The changes as a result of geometric operations in the solid model are not reflected in these features. While Cut-Off plies still appear in the sampling point, these plies show zero stress and strain during postprocessing.

Recomputation of ISS

The recomputation of interlaminar shear stresses only corrects the stresses of layered elements. Homogenous elements (Drop-Off and Cut-Off elements) retain the interlaminar shear stresses of the .RST file.

Interface Layers / Elements

Element faces located above and below an interface element must have the same shape (quadrilateral or tetrahedral). If their shapes are not the same, the interface element is removed. This can happen due to the effect of [Drop-Off elements \(p. 285\)](#) (as shown in the figure below). It can also happen when interface elements intersect a [Cut-Off Geometry \(p. 285\)](#) and the interface element is not updated. As a result, the interface element does not conform to the new shapes of the adjacent top and bottom elements.

Figure 3.37: A quadrilateral interface element surrounded by a brick element and two tetrahedral elements created when the Drop-Off is split

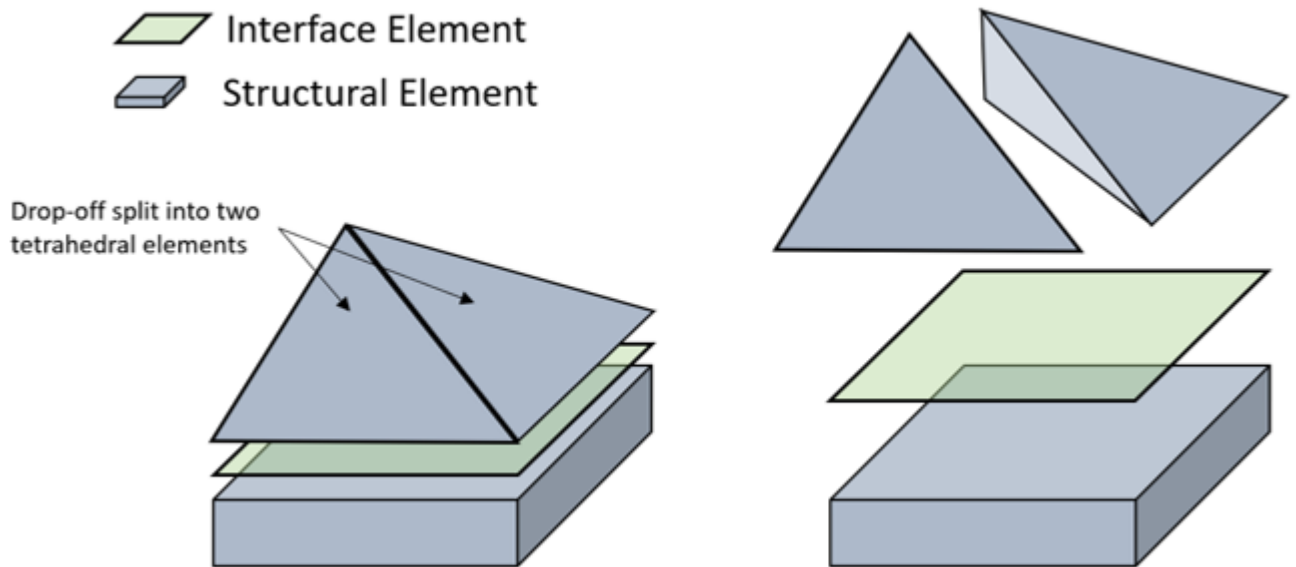

3.7. Guide to Composite Visualizations

There are several features available in ACP that help in visualizing a composite model. Some features aid in the verification of the lay-up definition. Others provide an insight into the stresses, strains, and failures and can thus help in the optimization of a structure.

This section aims to be a brief guide to the some of the available functionality.

3.7.1. Model Verification

Two features are very useful for checking the lay-up definition before solving the model. One is the **Orientation Visualization**, the other is the **Section Cut** feature.

The **Orientation Visualization** can display the direction and/or orientation of the elements, **Oriented Selection Sets**, and plies. Refer to [Scene Manipulation \(p. 23\)](#) for more information.

After the whole definition of the lay-up, a visual verification of the lay-up sequence can be very useful. **Section Cuts** offer a useful visual check once the lay-up has been determined. By defining one or several **Section Cuts**, the ply position (number in the sequence) and orientation can easily be verified. Refer to [Section Cuts \(p. 170\)](#) for more information.

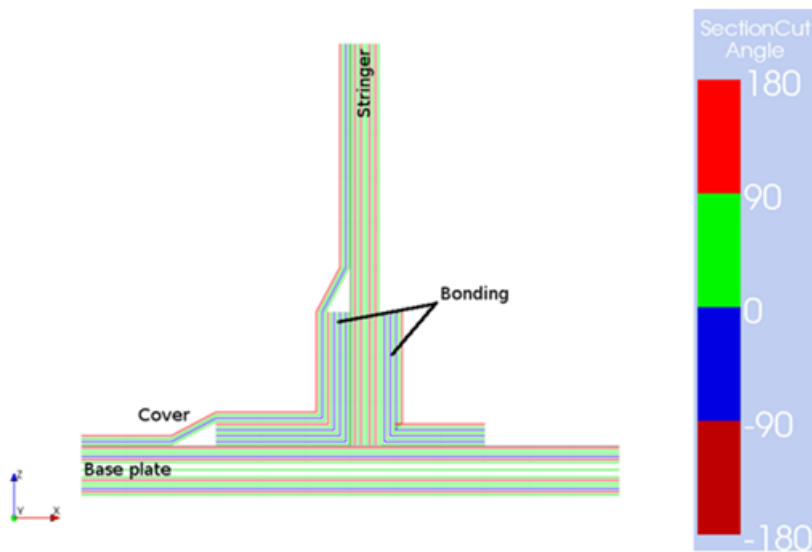
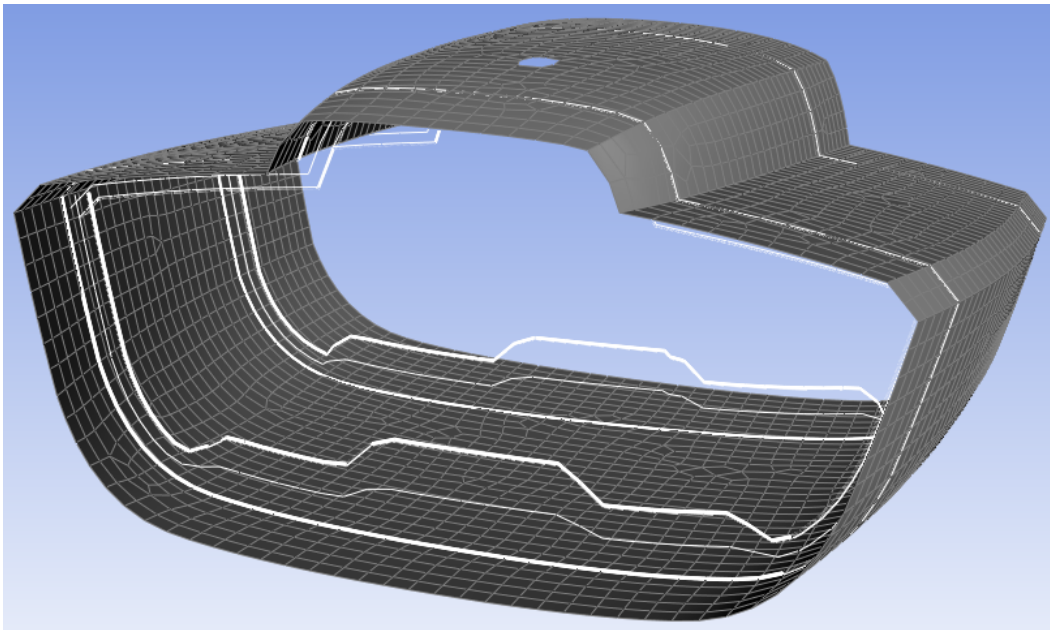
Figure 3.38: T-Joint Section Cut**Figure 3.39: Class40 Section Cut**

3.7.2. Postprocessing Visualizations

There are several features that can be used for viewing the results of a simulation. They all can give a different insight into the behavior of the composite structure. The different postprocessing visualizations mentioned below are also described in the last part of [Tutorial 1](#).

Composites are significantly more complex than isotropic materials because of their orthotropic material behavior and multiple possible failure modes (different types of fiber, matrix failure, etc.). Therefore, composites are evaluated based on standard results (such as deformation, stress, and strain) and on failure criteria to identify the first ply failure of the structure.

This section describes the use of the standard result objects in the Mechanical software for composite, ply-wise scoping, and failure criteria evaluation.

Deformation

In the Mechanical application, you can visualize the deformation of a structure with the following result objects: **Total Deformation** or **Directional Deformation**. The **Display Time** field in the Details panel enables you to plot the result at a specific time. The plot can be scaled by using the **Deformation Scale** in the Result tab's **Display** group.

Figure 3.40: Insert Deformation Object under the Solution Group

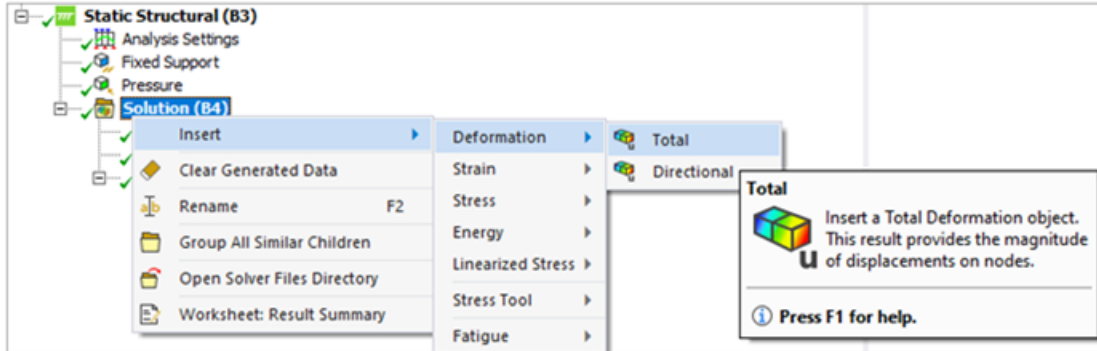
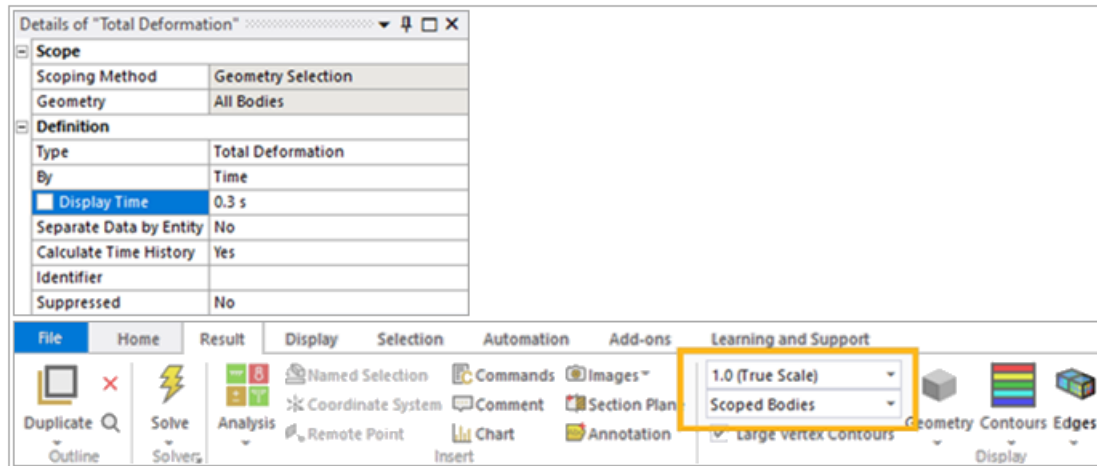

Figure 3.41: Modify the Display Time and/or Deformation Scale of the Result Object



Failure Criteria

The failure plot displays the critical safety factors (reserve factors, inverse reserve factors, and margin of safety) to first ply failure for a given failure criteria definition.

The safety factors are evaluated for every element of each layer and the critical value through the thickness of the lay-up is then projected on to the reference shell mesh. A failure plot for an envelope solution works in the same way and is a display of the most critical failure of all included solution sets. Alternatively, the safety factors can be displayed ply-wise for each analysis ply.

Before creating a failure plot, you must insert a **Composite Failure Tool** under the Solution and complete the failure criteria definition.

You can insert a **Composite Failure Tool** by right clicking the **Solution** group object, navigating to the **Composites** cell, and selecting the **Composite Failure Tool**.

Figure 3.42: Insert a Composite Failure Tool under the Solution

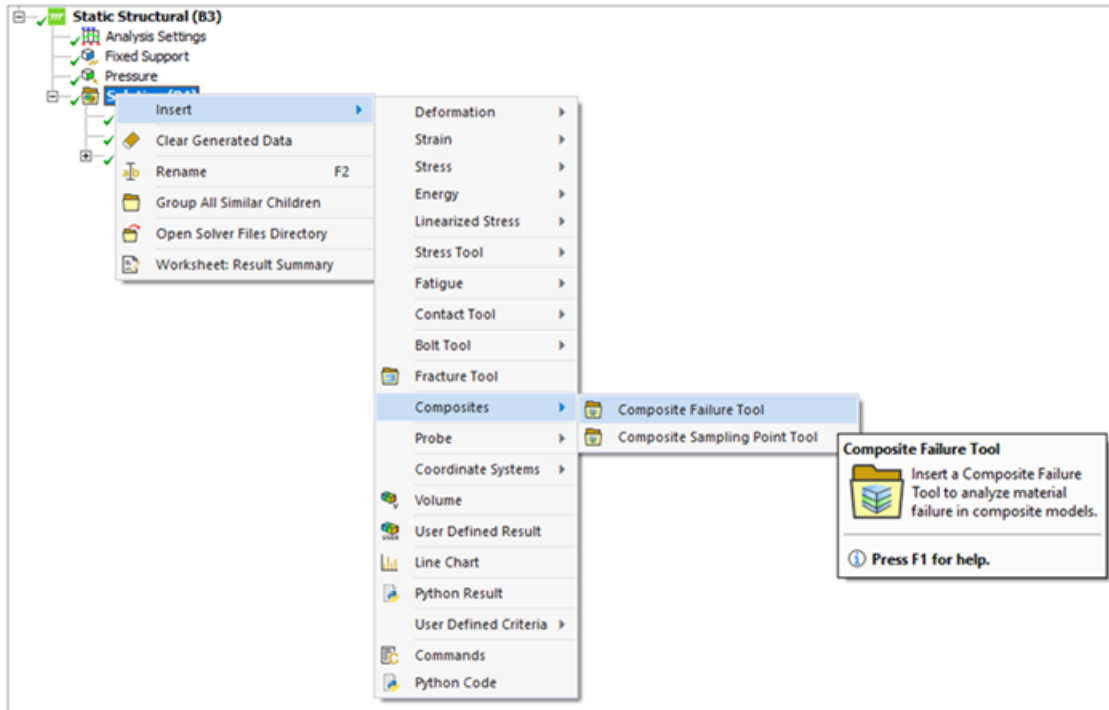

When you click the **Composite Failure Tool** group object, you can enable/disable the failure criteria in its Details panel. The failure criteria definition (such as the IRF) must be performed before creating the failure plot. When creating the failure criteria group, the IRF is inserted by default.

Figure 3.43: Configure the Failure Criteria definition in the Composite Failure Tool group

Details of "Composite Failure Tool"	
Definition	
Type	Composite Failure Tool
Reference	
Defined By	Direct Input
Reinforced Ply Criteria	
Maximum Strain	Off
Maximum Stress	On
Tsai-Wu	Off
Tsai-Hill	Off
Hoffman	Off
Hashin	Off
Puck	Off
LaRC	Off
Cuntze	Off
Sandwich Criteria	
Face Sheet Wrinkling	Off
Core Failure	Off
Shear Crimping	Off
Isotropic Material Criteria	
Von Mises	Off

Additionally, you can display the critical failure modes and critical plies as element labels. To configure the display setup, select the result object (for example, IRF) under the **Composite Failure Tool** and modify the respective fields in the Details panel.

Figure 3.44: Modify the Displayed Information (Failure Mode, Critical Layer)

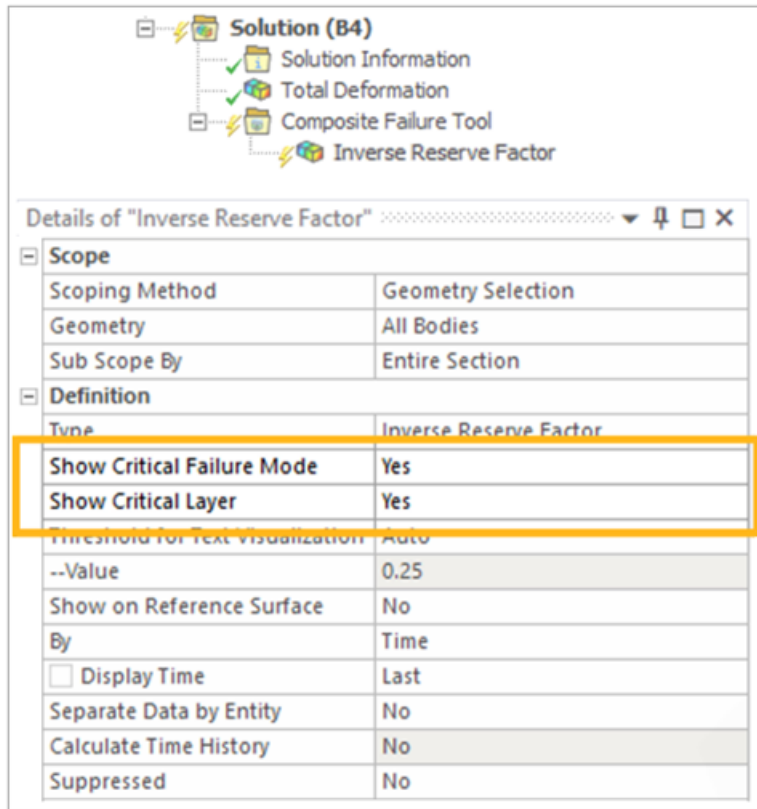

In the Details panel, you may also change the **Type** of failure (Inverse Reserve Factor, Safety Factor, Safety Margin).

Figure 3.45: Type of Failure Plot

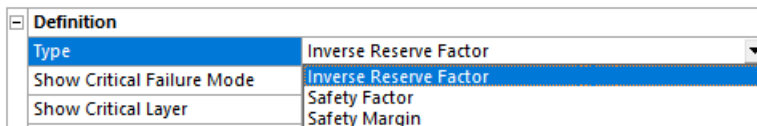

You can view and zoom in on the results.

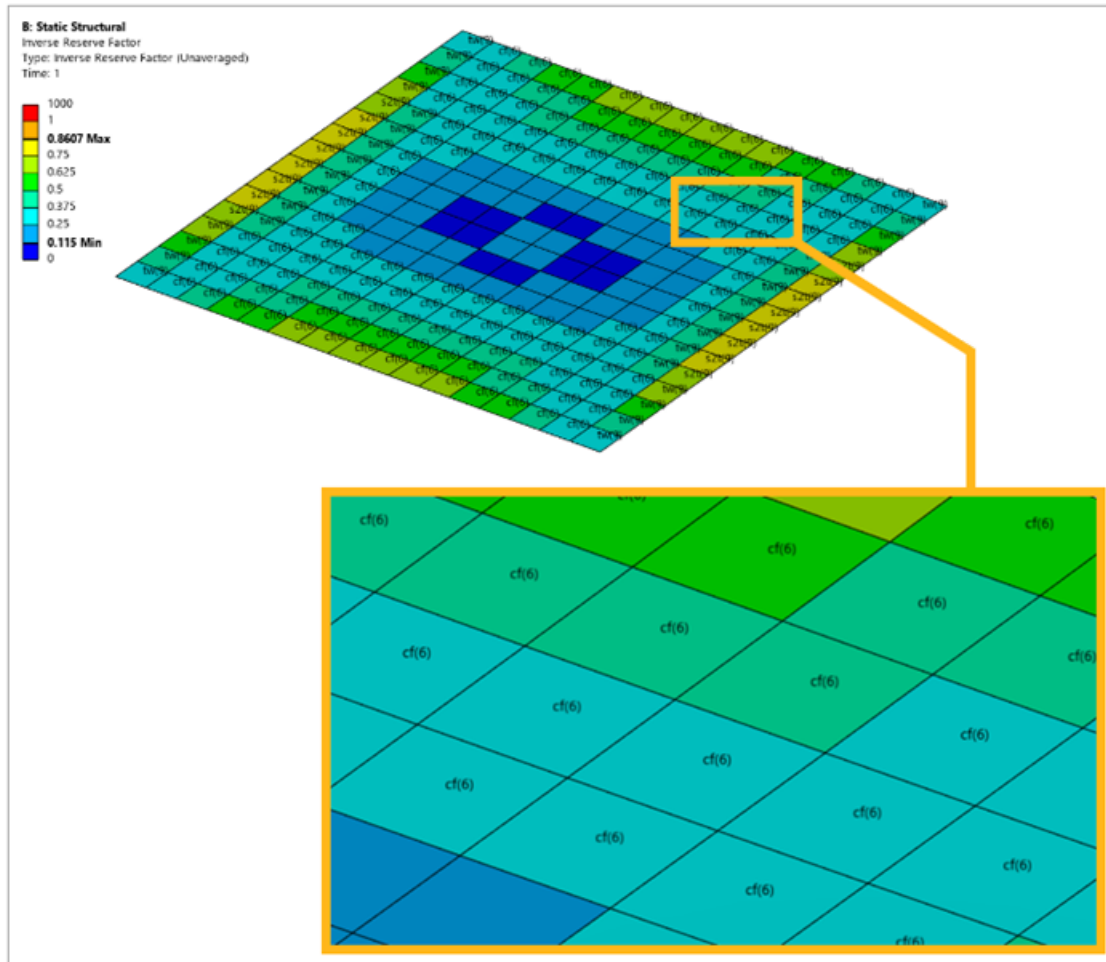
Figure 3.46: IRF Value, Text Plot for Each Element, and Zoom on Area (Tutorial 1)

Ply-Wise Results

The structural behavior throughout the lay-up at each layer is of great interest in composite design. Ply-wise information helps to identify and optimize layers that are critical and ones that are not.

All the solution plots except the deformation plot have the option of displaying results ply-by-ply. If a result object supports ply-scoping, then the **Sub Scope By** field will be exposed in the Details panel. Its options are **Layer** and **Ply**. To postprocess across the entire envelope of the selected geometries, select **Layer**. To evaluate only a selected ply, select **Ply**.

Evaluate the ply-wise results through the following steps:

1. In the respective solution plot Details panel, select **Ply** as the definition of the **Sub Scope By** field.

Figure 3.47: Active Ply-Wise Scoping

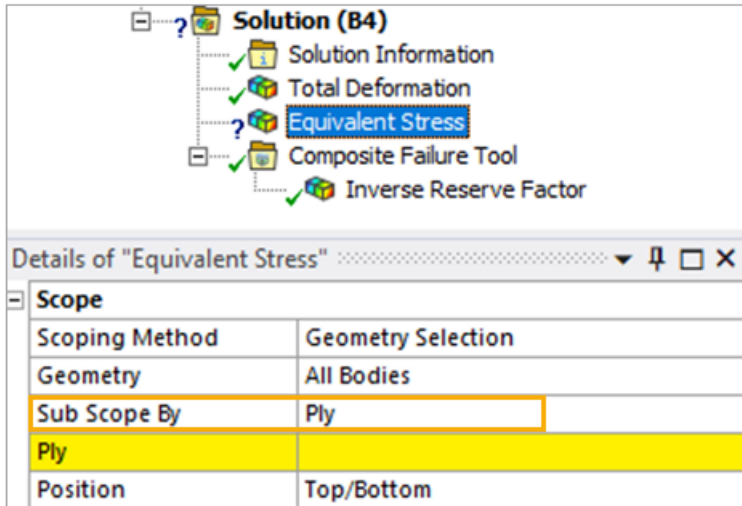

2. Select the respective **Ply** field.

Figure 3.48: Select Ply Field

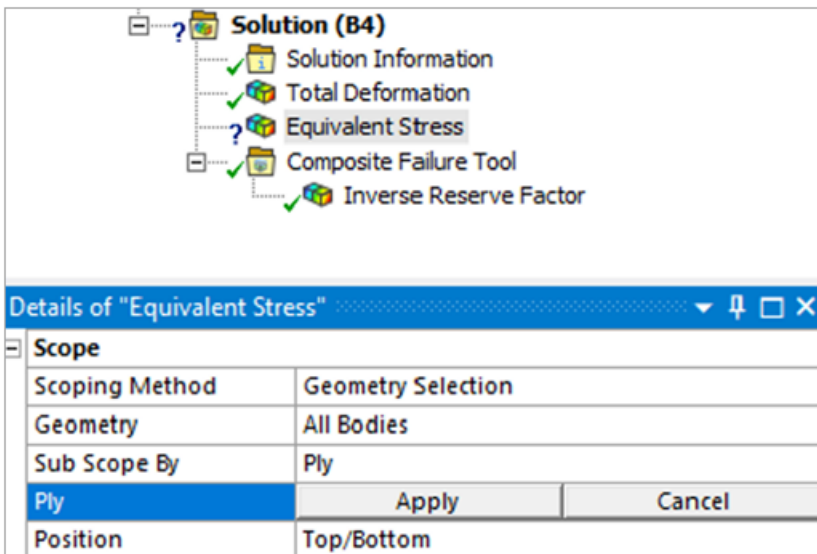

3. Navigate to the **Imported Plies** group and select the desired ply.

Figure 3.49: Select a Ply in the Imported Plies Group

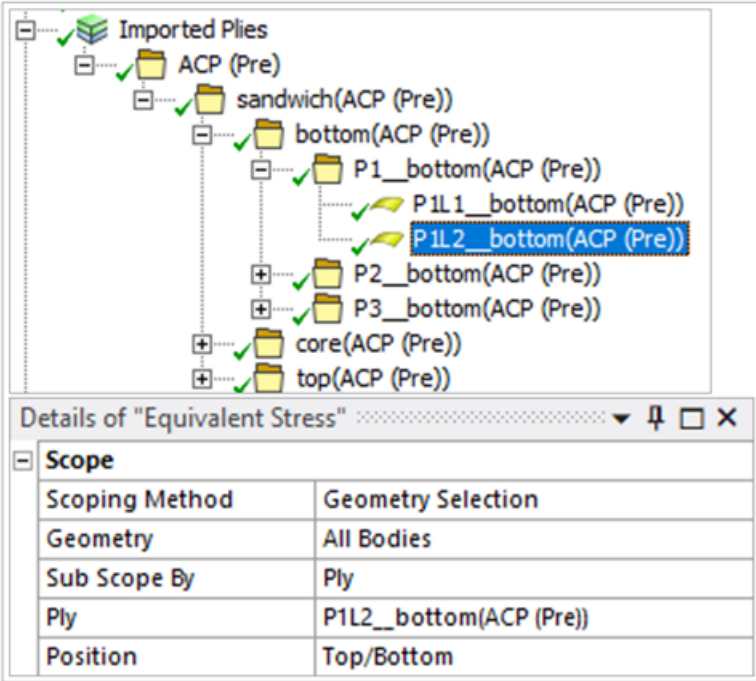

- 4. Return to the result object's **Ply** field and click **Apply**.
- 5. The result object can now be evaluated on the selected ply.

Figure 3.50: Evaluate the Result of Ply-Wise Scoping (Tutorial 1)

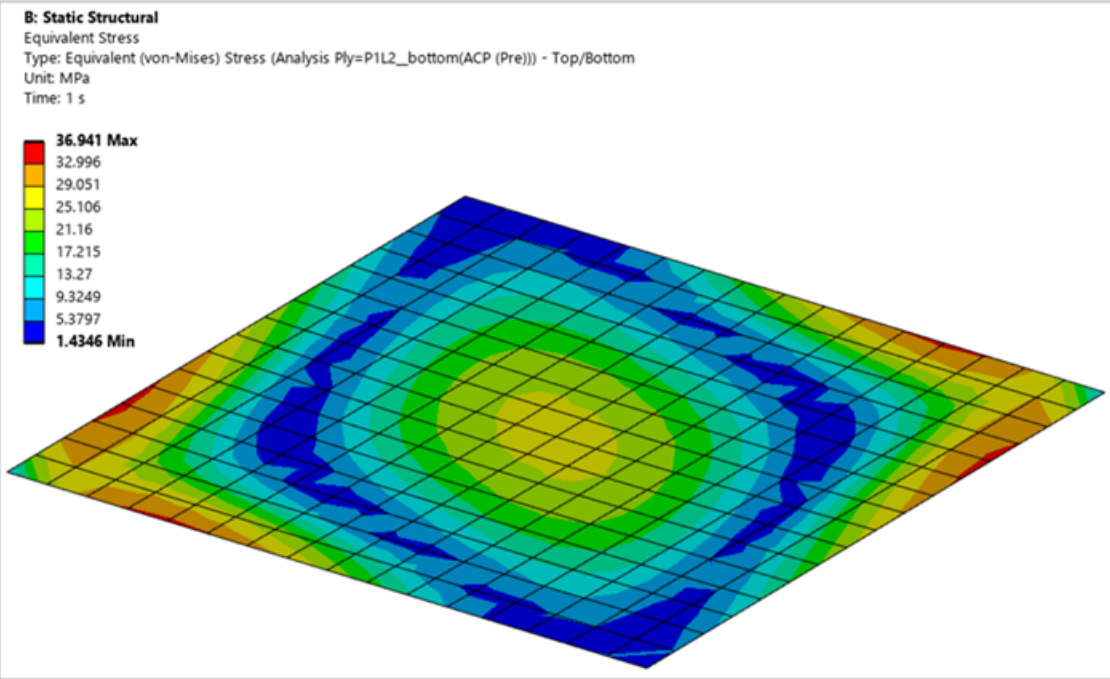

Sampling Point Results

Sampling Points are an alternative way of analyzing a lay-up on a ply level. A point of interest on the composite part is selected and its local lay-up is sampled. This feature can display failure criteria, stresses, and strains through the thickness of the laminate. In this way, the **Sampling Point** gives a detailed insight into the laminate behavior ply-by-ply.

Insert and evaluate a Sampling Point result through the following steps:

1. Insert a **Composite Failure Tool** group object and define the Failure Criteria using the steps explained in the [Failure Criteria \(p. 292\)](#) section.
2. Select the **Composite Failure Tool** group, then right-click and select the **Promote to Composite Failure Criteria** cell. That places a **Composite Failure Criteria Definitions** group under the **Model** in the Tree View, which contains the user-defined Composite Failure Criteria object.

Figure 3.51: Promote the Failure Criteria Definition of the Composite Failure Tool

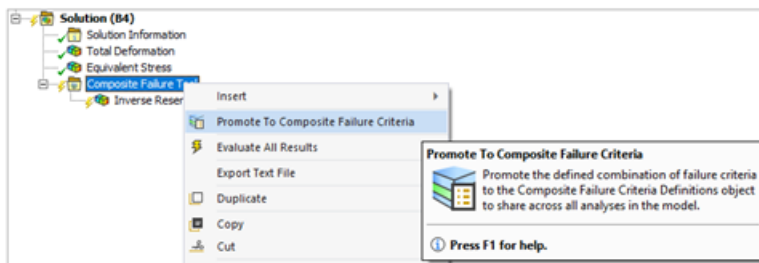

- a. In the Details panel of the **Composite Failure Tool**, the **Defined By** field now contains Composite Failure Criteria Definitions instead of Direct Input. This enables the Failure Tool to refer to the Criteria Definitions group for the Failure Criteria definition. By default, the promoted Composite Failure Criteria object is selected.
- b. The Composite Failure Criteria objects under the Composite Failure Criteria Definitions group can be modified, and the Failure result objects under the Solution which refer to them will be updated accordingly.

Figure 3.52: Modify the Promoted Composite Failure Criteria Object when Necessary

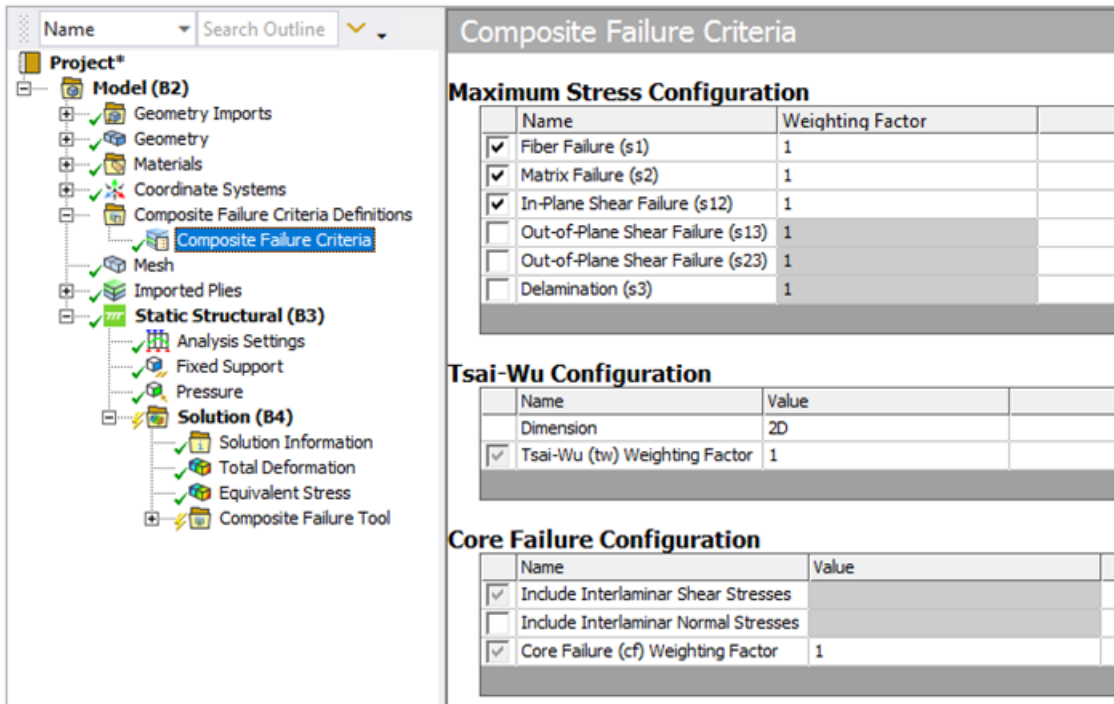

3. Right-click the **Solution** group object, navigate to the **Composites** field, and select the **Composite Sampling Point Tool**.

Figure 3.53: Insert a Composite Sampling Point Tool Object

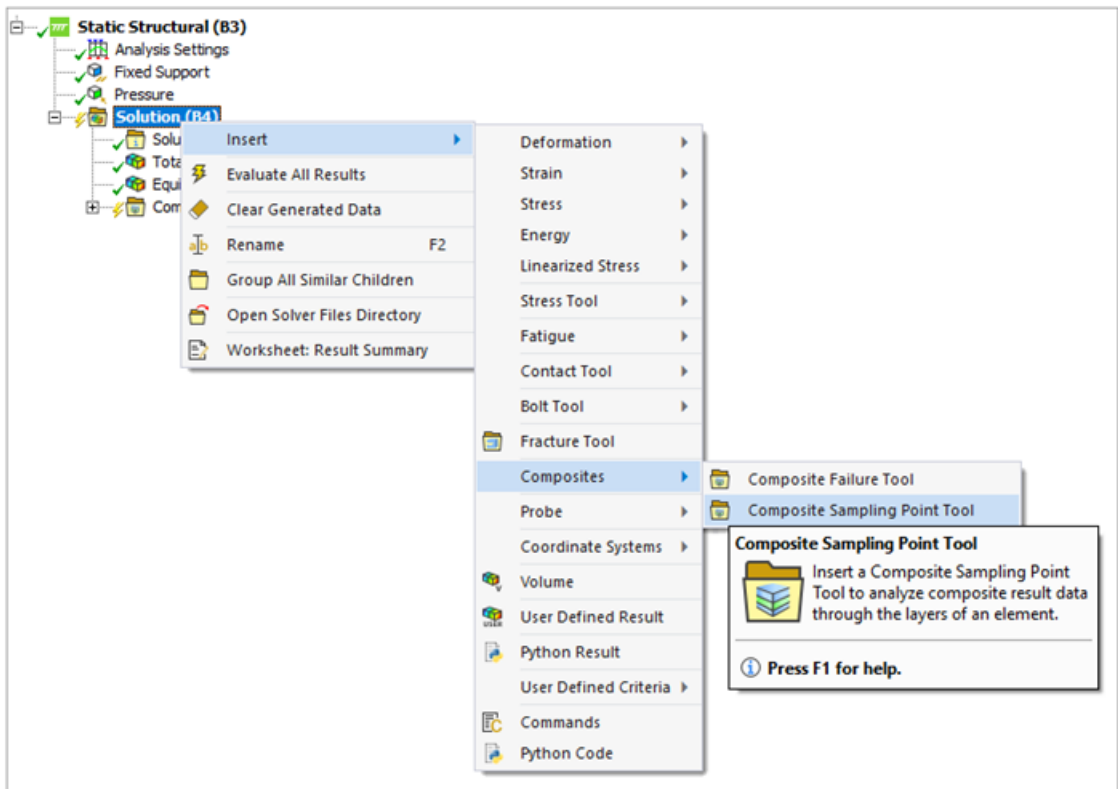

4. In the Details panel of the Composite Sampling Point Tool, select the promoted **Composite Failure Criteria**.

Figure 3.54: Select Failure Criteria under Sampling Point Tool Group

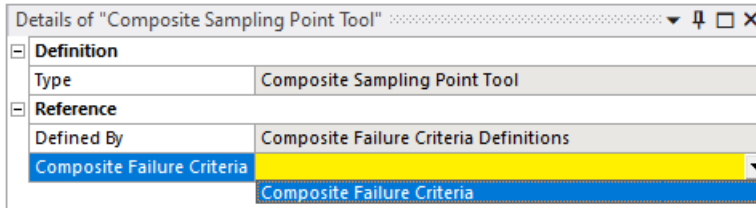

5. You can now choose a point and evaluate:
 - a. Select the **Composite Sampling Point** result object that has been automatically created under the respective group.
 - b. Click the **Geometry** field which is currently undefined.
 - c. Click any area of the Geometry and then Apply. The white cross on the Geometry represents the selected point.

Figure 3.55: Choose Sampling Point on Geometry and Apply Selection

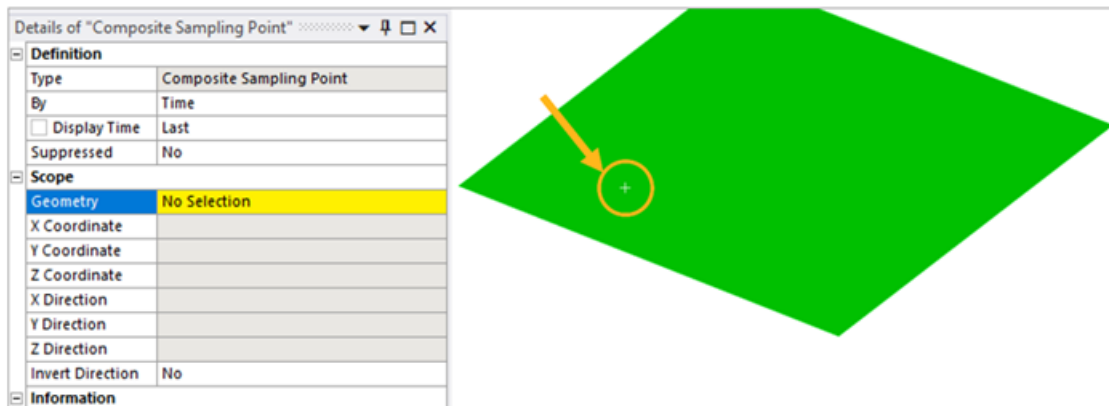

- d. The details of the selected point are reported under the Scope group of the object. You can redefine the point by navigating to the Geometry, selecting another target, and re-applying the selection.

Figure 3.56: Review the Selected Point

Scope	
Geometry	1 Face
X Coordinate	-61.84811145 mm
Y Coordinate	-90.14264494 mm
Z Coordinate	0. mm
X Direction	0.
Y Direction	0.
Z Direction	1.
Invert Direction	No

6. After evaluating the result, the **Worksheet** view is activated, where you can select which type of luyap to postprocess, the results (strain, stress, failure, and polar of the material), and annotation. You can also scale the core to modify the luyap plot visualization.

Figure 3.57: Evaluate the Sampling Point's Results

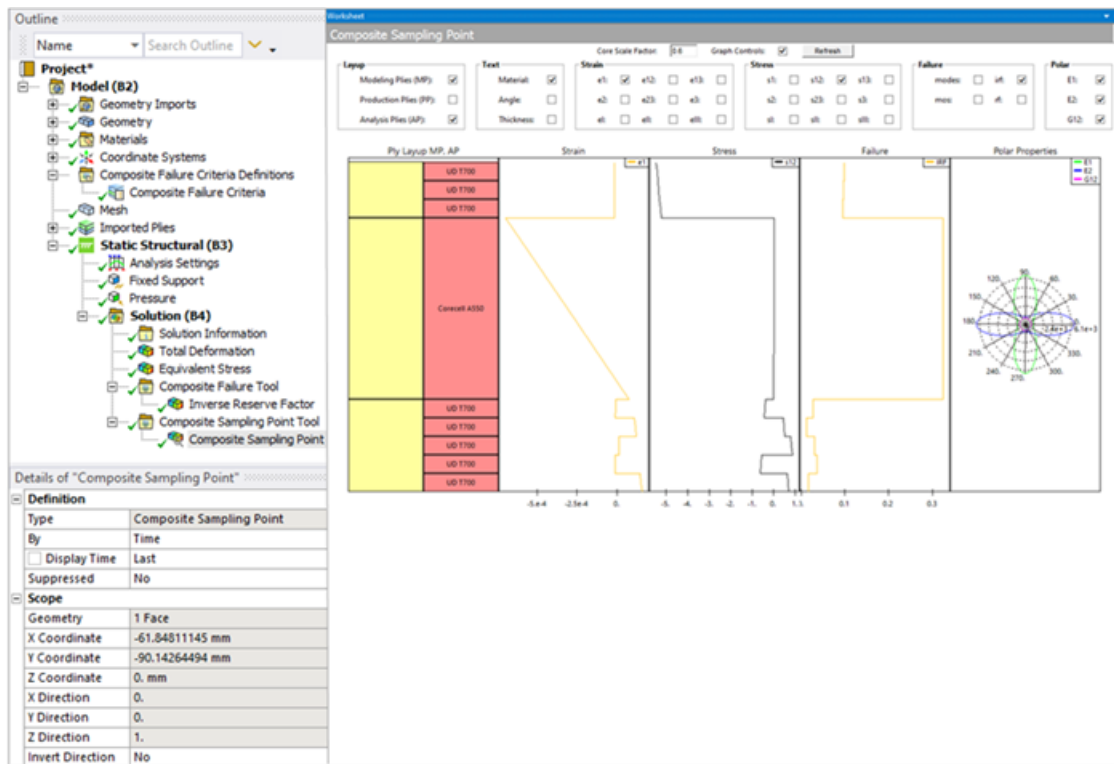

3.8. Guide to Composite Failure Criteria

The **Composite Failure Criteria Definitions** in the Mechanical application provide a number of failure criteria for the strength assessment of composites. Both established and basic as well as recent and advanced failure criteria are included in the program. This section provides some guidance on the selection of failure criteria.

- It is advised that you use failure criteria that distinguish between different failure modes (for example, fiber failure or matrix failure).
- The use of all-inclusive quadratic failure criteria is not advised (for example, Tsai-Wu, Tsai-Hill, or Hoffman). In most situations, these criteria are less accurate than others and provided minimal information on any failure.
- It is more conservative to combine different failure criteria (Puck, Max Stress, and LaRC) than using any single criterion.
- In general, failure criteria that consider all in-plane stresses (s_1 , s_2 , s_{12}) and the out-of-plane interlaminar shear stresses (s_{13} , s_{23}) should be used, as these results are available in a shell model.
- 3D stresses (s_3) can often be ignored in thin laminates with moderate curvature. Otherwise, Puck 3D can be used to investigate delamination.

- 3D solid models can be used to get more accurate results, especially if out-of-plane stresses are being investigated.
- Wrinkling and Core Failure should be evaluated for sandwich structures.
- The use of Puck 2D is recommended over the use of Puck Simplified.

For more information, see [Failure Analysis in the Composites Theory Reference](#) and [Postprocessing Usage Reference in the Mechanical User's Guide](#). A comprehensive comparison of composite failure criteria was carried out in the worldwide failure exercise [10 (p. 369)].

3.9. Element Choice in ACP

This section describes the composite modeling techniques for the use of shell, solid, and solid-shell elements.

[3.9.1. Introduction](#)

[3.9.2. Shell Elements](#)

[3.9.3. Solid Elements](#)

[3.9.4. Solid-shell Elements](#)

3.9.1. Introduction

The underlying principle of ACP is that a composite lay-up is defined on a shell geometry. The model of the lay-up that is passed from the ACP preprocessor to the solver can be a shell element mesh but also a solid or a solid shell element mesh. The solid model mesh is an extrusion of the shell element input mesh. If this input shell mesh uses linear elements ([SHELL181](#)) the solid model mesh generated in ACP can have either layered solid elements ([SOLID185](#)) or layered solid shell elements ([SOLSH190](#)). If it is quadratic ([SHELL281](#)) the solid model mesh can only have quadratic layered solid elements ([SOLID186](#)).

The geometry and loading of the engineering problem ultimately dictate what element type is best suited for the analysis. The following sections outline a few general considerations about the element types in ACP. For more detailed information, see [Element Library](#) in the [Mechanical APDL Theory Reference](#).

3.9.2. Shell Elements

Shell elements are suited for modeling thin-walled to moderately thick-walled structures. Shell elements are compliant in bending and give good deformation results while being computationally inexpensive.

3.9.3. Solid Elements

Solid elements are aimed at modeling thick walled structures. As laminate thicknesses increase, out-of-plane stresses become more significant; Solid elements are better at approximating these effects. Furthermore, layered solid elements allow the incorporation of composite parts in larger solid model assemblies.

A shortcoming of these element types is that they are typically too stiff in bending when elements are thin. Displacements can be wrong by an order of magnitude as the elements undergo a phenom-

on called locking. Element technologies such as Enhanced Strain Formulation try to remedy this numerical locking but are not sufficient to do so in linear 3D solid elements. Quadratic solid elements (SOLID186) offer a better solution, however, this comes at an increased computational cost.

3.9.4. Solid-shell Elements

Solid-shell elements cover the spectrum between shell and solid elements and are best suited for modeling thin to moderately thick structures. Thin solid-shell elements do not undergo locking and are able to give good results for out-of-plane stresses and strains.

3.10. Variable Material Data in Composite Analyses

Composite modeling in Workbench provides the possibility to account for variability in the mechanical properties of composite materials due to any scalar user-defined quantity. Temperature, Shear Angle (defined through ACP (Pre) [draping \(p. 279\)](#)), and Degradation Factor are predefined variables in Workbench Engineering Data to be used for refining a composite material's behavior. You are free to define your own field variables.

The following mechanical properties can be defined as variable:

- Isotropic elasticity
- Orthotropic elasticity
- Orthotropic stress limits
- Orthotropic strains limits

Dependencies are specified in tabular form in [Engineering Data](#).

An interpolation scheme is used to evaluate the locally effective properties given the local field variable states in the model. For information on how the interpolation scheme is controlled, see [Variable Data Interpolation Settings \(p. 305\)](#).

Once the dependencies are defined in Engineering Data, they are accounted for in subsequent composite analyses and postprocessing. The Shear Value is defined by draping simulation in ACP (Pre), the Temperature is computed or defined in Structural, Transient Thermal, or External Data systems. The state of all other fields should be defined in ACP (Pre). The state of all other fields can be defined by means of Field Definitions in ACP (Pre) or External Data systems.

Variable material data is compatible with both shell and solid elements.

An example analysis using variable material data is given in [Analysis Using Variable Material Data \(p. 320\)](#).

3.10.1. Element- or Layer-wise Field Definition

You can specify the distribution of any variable used in the definition of a Variable Material in ACP. This is done by means of Look-up Tables. A scalar Look-up Table column can be associated with a field variable. The state of the field variable is interpolated from the scalar Look-up Table column over the finite element model. To this end, you can specify whether this interpolation is applicable for the entire model or only specific parts of it. The field definition can be scoped to a combination of:

- Element Sets
- Oriented Selection Sets
- Modeling Plies

Element Sets or Oriented Selection Sets as scope of the field definition always affect all layers of their underlying finite elements. In contrast, scoping to Modeling Plies refines the selection to specific layers of their underlying finite elements. The Field Definition then applies to the layers of the covered finite elements associated with the Analysis Plies of each Modeling Ply. Elements and layers not covered with a field variable definition assume the default value for this variable.

Altogether, a Field Definition can be scoped to the full FE-model or refined to affect only subparts and, furthermore, only layers.

See the [Field Definition \(p. 165\)](#) for additional information about the object as well as object set-up.

3.10.2. Draping Shear

Ply draping on arbitrarily shaped surfaces leads to local shearing of the plies. This manufacturing-induced artifact can lead to significant deviation between the assumed and effective mechanical properties. This is because the shearing can be on the order of several degrees before ply wrinkling becomes an issue. Thus, the configuration of the composite can vary considerably from point to point, as can the mechanical properties.

In order to reflect the mechanical properties' dependence upon draping shear, ACP (Pre) provides a draping simulation tool. Upon specifying shear-dependent material properties in Engineering Data and enabling [draping \(p. 279\)](#) in ACP (Pre) for individual plies or Oriented Selection Sets, downstream analysis systems take this effect into account.

The draping shear angle is defined as:

$$|\text{draped_transverse_angle} - \text{draped_fiber_angle}| - 90$$

Where "draped_fiber_angle" and "draped_transverse_angle" denote the angles of the draped fiber and transverse directions with respect to the reference direction, respectively. Thus, a shear angle of 0 degrees indicates that the ply at the corresponding location is unsheared.

3.10.3. Degradation Factors

Composite parts can exhibit a number of artifacts leading to local degradation of mechanical properties. Such flaws can be the result of a manufacturing process or can develop during operation. Examples of these types of flaws include voids, imperfect resin impregnation of fibers, deviation of the fiber alignment from the design angle, and resin traps.

If such artifacts are known, you can account for them using degradation factors. The typical assumption is that a degradation factor of 1.0 indicates a sound material, while a degradation factor of 0.0 implies a disintegrated material. Degradation-dependent material properties can be specified in [Engineering Data](#).

3.10.3.1. Definition of the Degradation Factor Field

The degradation factor fields are defined by means of a Field Definition object. If Degradation Factor has been used to define one of the [materials in Engineering Data](#) for the current composite analysis, you can select it from the drop-down menu under Field Variable Name, as shown in the Figure below. The scope of applicability of this Field Definition is set under Scope Entities to a combination of Element Sets, Oriented Selection Sets and Modeling Plies. The degradation factors are interpolated from the selected Look-up Table Column upon update of the ACP system: for shell elements the field state values are evaluated at the element centroid taking into account the actual ply offsets if Include Shell Offset is activated; for solid elements the actual ply position is always considered and this behavior cannot be changed.

All downstream analysis systems will make use of the information provided for the Degradation Factor in the Field Definition object.

Figure 3.58: Field Definition Properties to Set Up a Degradation Factor Field

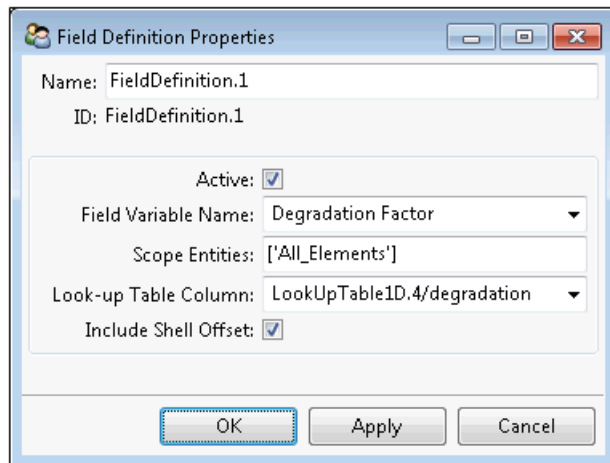

3.10.4. Definition of General User-Defined Fields in ACP (Pre)

The Engineering Data enables you to define Isotropic and Orthotropic Elasticity as well as Stress and Strain limits as a function of up to nine user-defined scalar field variables. Engineering Data pre-defines Temperature, Degradation Factor and Shear Angle fields. If necessary, you can add custom field variables. From within ACP, the custom field variables have to be defined as described by [Field Definition Object Properties](#) (p. 165) for Element- or Layer-wise definitions. From the Workbench-level, External Data components can be used to define custom field variables. Please note, however, that External Data components do not permit layer-wise field definitions.

3.10.5. Variable Data Interpolation Settings

The interpolation algorithm and its settings can be controlled from Workbench Engineering Data. For details on the interpolation schemes available and settings of the interpolation engine, see [General Interpolation Library in the Composites Theory Reference](#).

Chapter 4: Example Analyses

The following examples demonstrate some of the commonly used features and workflows in ACP. Other examples and tutorials can be found in the [ACP Tutorials](#). You must be familiar with the basics of the software to understand the analysis examples in this section.

- 4.1. Analysis of a Composite Shell Model
- 4.2. Analysis of a Composite Solid Model
- 4.3. Analysis Using Variable Material Data
- 4.4. Analysis of a Mapped Composite Solid Model
- 4.5. Shear Dependent Materials in Composite Analysis
- 4.6. 3D Ply Workflow – Imported Plies
- 4.7. ACP for Workbench LS-DYNA: Bird Strike
- 4.8. Workflow with Equivalent Beam Models

4.1. Analysis of a Composite Shell Model

[Tutorials 1 and 2](#) give a good insight into the ACP functionality. While the tutorials always start with an existing model this section outlines the generic build-up of a composite shell model. Selected steps are explained in more detail below and highlighted with a link.

- **Preprocessing**
 - [Add ACP \(Pre\) Component to the project \(p. 308\)](#)
 - [Define Engineering Data \(p. 309\)](#)
 - [Import or construct Geometry \(Units\) \(p. 312\)](#)
 - Open the Model and
 - [Define Named Selections/Element Sets \(p. 312\)](#)
 - Generate Mesh
 - [Open ACP \(Pre\) \(p. 312\)](#) and
 - Define Fabric
 - Define Rosettes and Oriented Selection Sets
 - Create Modeling Plies
- **Workbench Analysis System**

- Add Analysis System to the project (p. 313)
- Open the Analysis System and
 - Define Analysis Settings
 - Define Boundary Conditions
- Solve model (update the project)
- **Postprocessing**
 - Postprocess Results in the Mechanical Application (p. 314)

4.1.1. Preprocessing

The steps involved in pre-processing are described in the sections below:

- 4.1.1.1. Workbench Integration
- 4.1.1.2. Adding ACP Components to the Project
- 4.1.1.3. Engineering Data
- 4.1.1.4. Properties
- 4.1.1.5. Geometry and Units
- 4.1.1.6. Named Selections and Elements/Edge Sets
- 4.1.1.7. Starting and Running ACP

4.1.1.1. Workbench Integration

The Workbench Add-in of ACP installs two additional Component Systems to the Workbench Toolbox: ACP (Pre) and ACP (Post). These systems allow transferring the composite definitions of ACP between ACP and Mechanical on the Workbench schematic level. ACP is now fully integrated in the data structure of Ansys Workbench and the update and refresh logic.

It is important that the user updates (refresh) the upstream data to pass the modifications to the ACP components. The update symbols can be used to check the up-to-date status of each component.

4.1.1.2. Adding ACP Components to the Project

The components ACP (Pre) and ACP (Post) are available in the **Toolbox** menu.

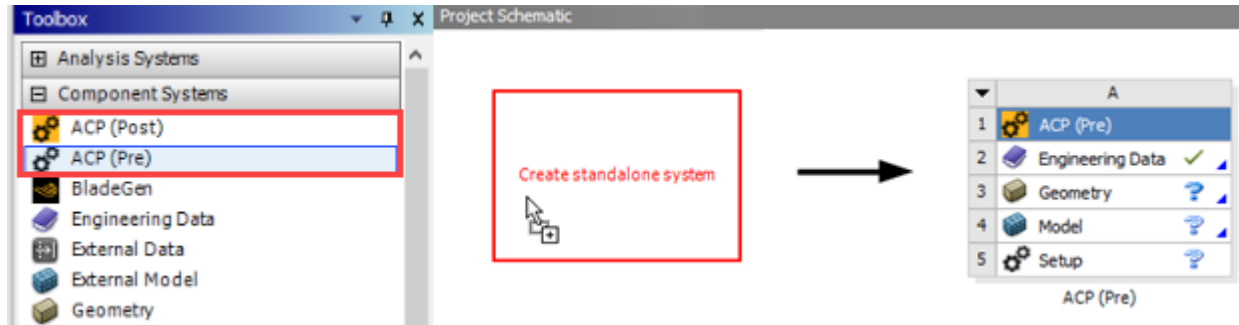
Figure 4.1: ACP Components

These components are handled in the **Project Schematic** like the other standard components (drag-and-drop or right mouse-click menu).

4.1.1.3. Engineering Data

With the installation of ACP a new material catalog named **Composite Materials** is available in the databank. This catalog contains typical materials used in composite structures like unidirectional and woven carbon and glass, or core materials. Within the Workbench workflow of ACP, the materials have to be defined in **Engineering Data** and not in ACP (Pre).

Figure 4.2: Engineering Data Sources

Engineering Data Sources				
	A	B	C	D
1	Data Source		Location	Description
2	★ Favorites			Quick access list and default items
3	📁 General Materials	<input type="checkbox"/>		General use material samples for use in various analyses.
4	📁 General Non-linear Materials	<input type="checkbox"/>		General use material samples for use in non-linear analyses.
5	📁 Explicit Materials	<input type="checkbox"/>		Material samples for use in an explicit analysis.
6	📁 Hyperelastic Materials	<input type="checkbox"/>		Material stress-strain data samples for curve fitting.
7	📁 Magnetic B-H Curves	<input type="checkbox"/>		B-H Curve samples specific for use in a magnetic analysis.
8	📁 Thermal Materials	<input type="checkbox"/>		Material samples specific for use in a thermal analysis.
9	📁 Fluid Materials	<input type="checkbox"/>		Material samples specific for use in a fluid analysis.
10	📁 Composite Materials	<input type="checkbox"/>		Material samples specific for composite structures.
*	Click here to add a new library		...	

Figure 4.3: Outline of Composite Materials

	A	B	C	D	E
1	Contents of Composite Materials		Add source		Description
2	Material				
3	Epoxy_Carbon_UD_230GPa_Prepreg	+		-	
4	Epoxy_Carbon_UD_230GPa_Wet	+		-	
5	Epoxy_Carbon_UD_395GPa_Prepreg	+		-	
6	Epoxy_Carbon_Woven_230GPa_Prepreg	+		-	
7	Epoxy_Carbon_Woven_230GPa_Wet	+		-	
8	Epoxy_Carbon_Woven_395GPa_Prepreg	+		-	
9	Epoxy-EGlass_Wet	+		-	
10	Honeycomb	+		-	
11	SAN Foam 103kqm3	+		-	

4.1.1.4. Properties

To fulfill the ACP requirements, the materials in Ansys Workbench have some additional properties which are highlighted below.

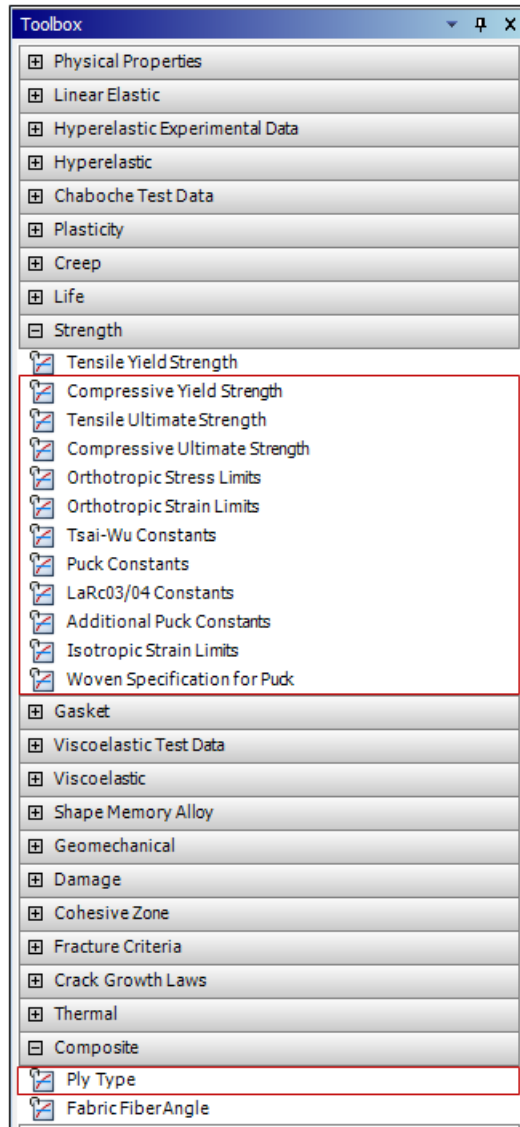
Figure 4.4: Material Properties for ACP**The new properties are:**

- **Ply Type:** Physical behavior of the material like core, unidirectional or woven ply.
- **Strengths:**
 - Orthotropic Stress Limits
 - Orthotropic Strain Limits
 - Isotropic Strain Limits
- **Composite Failure Parameters:**
 - Tsai-Wu Constants
 - Puck Constants

- LaRc03/04 Constants
- Additional Puck Constants
- Woven Specification for Puck.

More information about the ACP material definitions are described in Section [Material Data \(p. 74\)](#).

4.1.1.5. Geometry and Units

A shell geometry is required for building any composite model in ACP. The geometry can either be constructed in the Ansys DesignModeler or imported as a CAD file.

The ACP unit system is independent from the unit system in the Mechanical application (user interface or solver). The transfer from the Mechanical application to ACP and vice versa automatically converts the data. The current unit system is displayed in the status bar of ACP at the bottom of the screen.

4.1.1.6. Named Selections and Elements/Edge Sets

Named Selections based on bodies, surfaces, and edges defined in the DesignModeler or the Mechanical application are transferred to ACP as an Element Set and Edge Set, respectively. They are necessary for building a composite model.

4.1.1.7. Starting and Running ACP

First, an **ACP (Pre)** component has to be defined in the Workbench project. Double-click **Setup** to open ACP (Pre). You can also use the context menu and select **Edit**, or run a Python script in which the ACP commands are included, from the context menu. After defining the composite data in ACP (Pre), you can return to the Workbench project to proceed. The ACP data is saved with **Save** in the Workbench project or any other **Save Project** command in the different components.

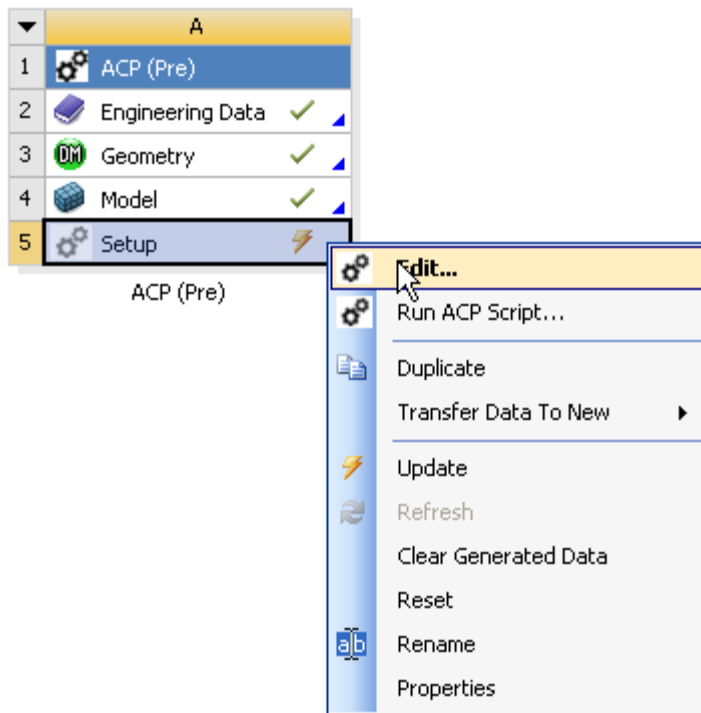
Figure 4.5: Context Menu of ACP (Pre) Setup

4.1.2. Workbench: Adding an Analysis System to the Project

The ACP components are handled in the Workbench **Project Schematic** like any other standard components. The components can be connected by drag-and-drop operations or by using the context menu. The Mesh, Engineering Data, Named Selections and Coordinate Systems are transferred to the analysis system.

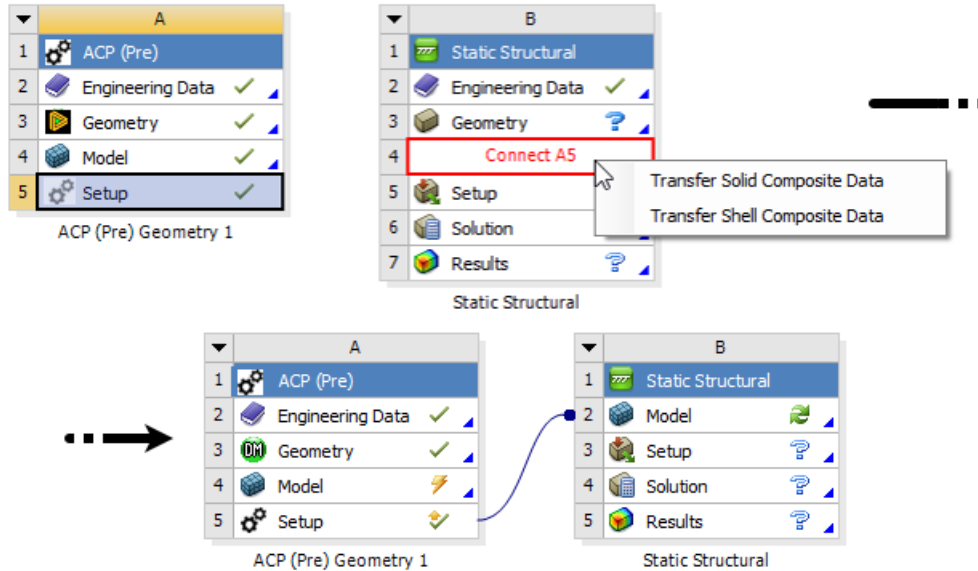
Figure 4.6: Connecting a Static Structural Analysis to ACP (Pre) using a Drag and Drop Operation

4.1.3. Postprocessing

For postprocessing in the Mechanical application, see [Postprocessing of a Composite Shell Model in the *Mechanical User's Guide*](#).

4.2. Analysis of a Composite Solid Model

In the case of thick composites, the layered shell theory can cause significant errors in the obtained results. In some cases, it is necessary to work with 3D models - also referred to as solid models. ACP has the unique feature that can generate layered solid models based on the shell lay-up definitions. ACP generates layered solid elements based on the shell mesh and the ACP composite definitions, thus representing one-to-one the composite part. Drop-offs, staggering and tapering are also considered. In addition, the solid model extrusion allows you to define extrusion directions and boundary curves.

In this section, the workflow of modeling a composite solid is outlined as it differs to some extent from shell modeling. Selected steps that differ from shell modeling are explained in more detail below and highlighted with a link.

• Preprocessing

- Add **ACP (Pre)** component to the project
- Define Engineering Data
- Import or construct Geometry
- Open the Model and
 - Define Named Selections/Element Sets
 - Generate Mesh

- Open ACP (Pre) and
 - Define Fabric
 - Define Rosettes and Oriented Selection Sets
 - Create Modeling Plies
 - [Create Solid Model \(p. 315\)](#)
- **Workbench Analysis System**
 - [Choose an Analysis System \(WB Mechanical/Mechanical APDL\) \(p. 316\)](#)
 - [Add Analysis System to the project \(p. 317\)](#)
 - [Add other systems \(p. 320\)](#)
 - Open the Analysis System and
 - Define Analysis Settings
 - Define Boundary Conditions
 - Solve model
- **Postprocessing**
 - [Postprocess Results in the Mechanical Application \(p. 320\)](#)

4.2.1. Preprocessing

Creating a Solid Model

You can generate a Solid Model by performing a mesh extrusion which converts the shell-based lay-up definition into a layered, solid-element mesh. The configuration of the extrusion happens in ACP (Pre) with the Solid Model feature. (For details, see [Solid Models \(p. 183\)](#) in the Usage Reference chapter.) The options and advanced settings of the Solid Model feature control the extrusion, shape, and mesh quality. See [Guide to Solid Modeling \(p. 283\)](#) for practical tips and recommendations.

The Export settings for the Solid Model control how it is exported for downstream analysis. For instance, you can choose between different element types (layered solid185 or solsh190). Within Workbench, the element and node labels are automatically handled to avoid numbering conflicts. (See the section on [Assembly \(p. 50\)](#).) If automatic numbering is disabled, then the numbering options can be used to specify the initial labels.

In addition, Element Sets and Edge Sets are transferred from **ACP (Pre)** to the downstream analysis system (**Mechanical Model**) where they appear as Named Selections. This aids the definition of boundary conditions and contacts, for instance, and makes your model associative. (See the section on [Solid Model Properties \(p. 185\)](#) for more information.) The figure below shows how Named Selections of the shell geometry are converted into Named Selections of the solid mesh (geometry). An edge becomes a wall (edge_1 ⇒ EDGE_1_WALL) and a surface is converted into a bottom and top surface (face ⇒ FACE_BOT and FACE_TOP) in the solid of the downstream **Mechanical** system.

Figure 4.7: Conversion of the Named Selections in the Solid Model Workflow

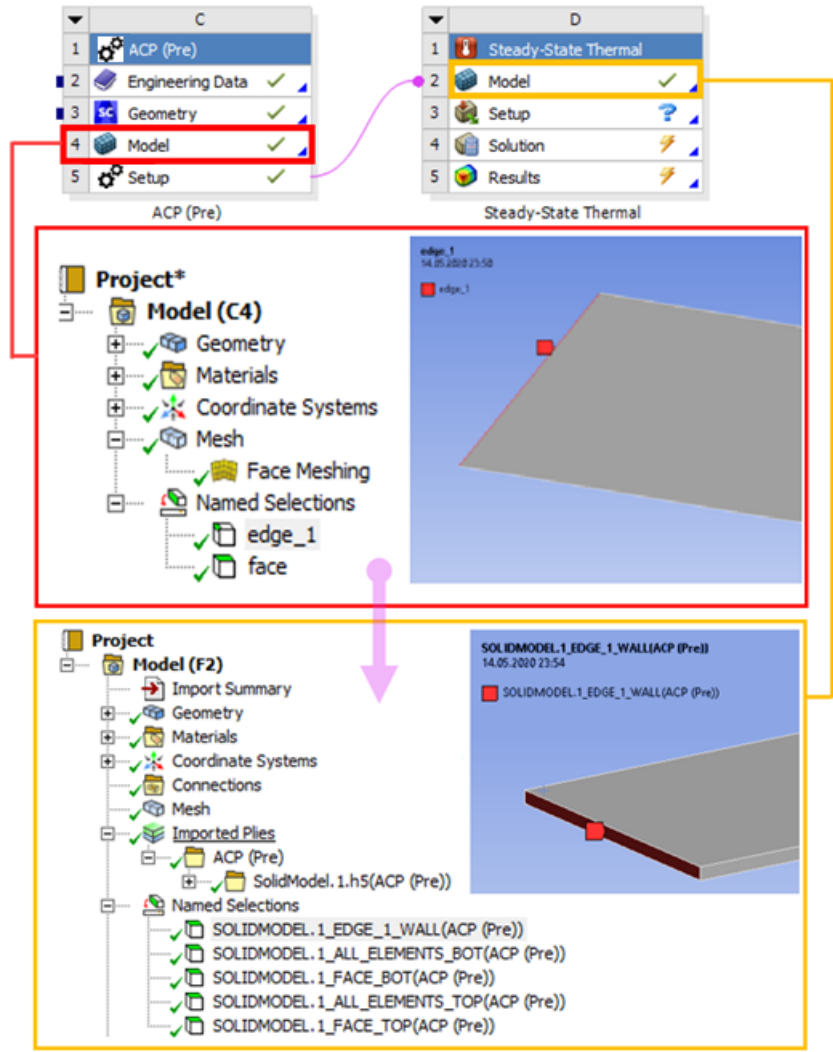

4.2.2. Workbench Application Analysis System

Within the Ansys Workbench application, there are two ways to analyze composite solid models: The analysis can be done in the Workbench Mechanical application, or it can be carried out in the Mechanical APDL software (Ansys Classic). While the functionality is identical, the user interface is very different. As an alternative, composite solid models can be exported from the ACP application for processing outside of Ansys.

Analysis with Mechanical Application

In the Mechanical application, the composite layered solid element model appears as a meshed body. Any other bodies in the ACP (Pre) component are not carried forward. You can define loads, boundary conditions, and connections to other parts in the Mechanical application as usual. An example of such a solid model workflow is shown below:

Figure 4.8: Workbench Software Workflow for Composite Solid Modeling with Mechanical Application

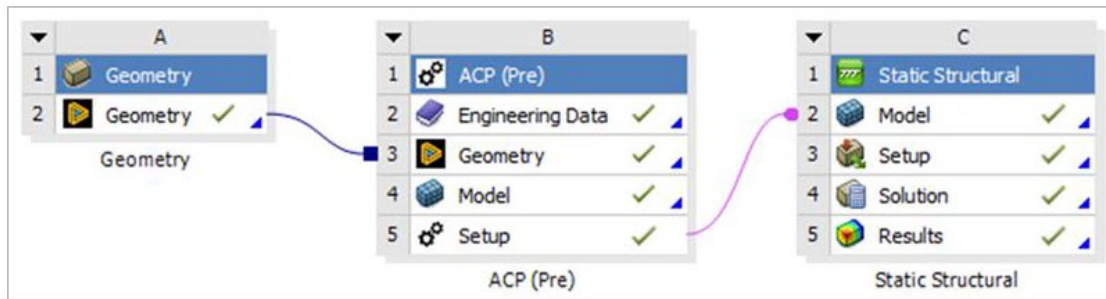

Analysis with Mechanical APDL Application

A further option is to link solid models to a Mechanical APDL application system where the boundary conditions and loads are defined. Typically, an APDL script is used to set boundary conditions and analysis settings for a workflow with the Mechanical APDL application. An example of a solid model workflow with the Mechanical APDL application is shown below:

Figure 4.9: Workbench Software Workflow for Composite Solid Modeling with Mechanical APDL Application

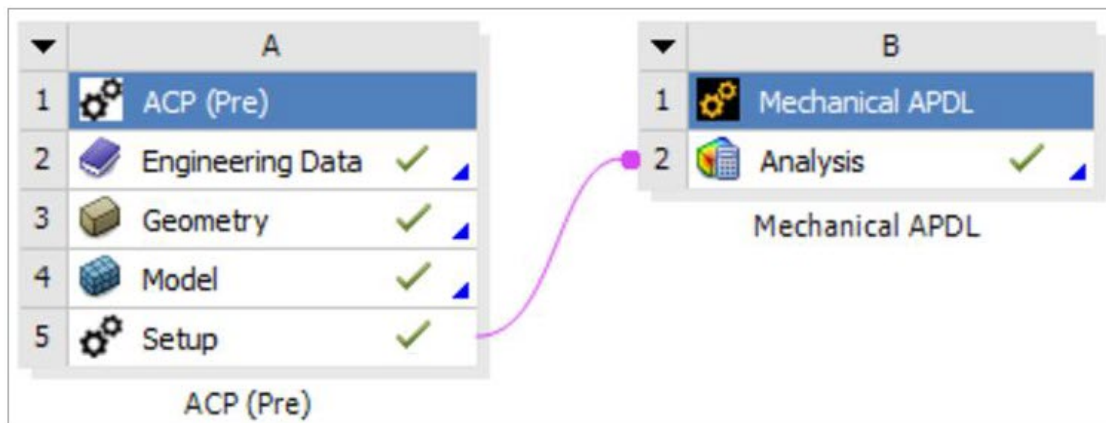

Adding an ACP (Pre) Component to the Project

The solid modeling workflow in Ansys enables the assembly of many preprocessing components into one analysis system. In some cases, it may be desirable to analyze thick-walled composites in isolation but often it is desirable to see the interaction between multiple bodies. The connection procedure is explained with the help of two examples for both analysis methods (Workbench Mechanical and Mechanical APDL applications).

Link with Workbench Mechanical Application

The procedure for building an analysis model is illustrated with a **Static Structural Analysis system** as an example. A composite doubly-curved tensile test specimen is held by two metallic grips at its two ends. Both the composite and the metallic parts are integrated into an assembly model.

A **Project Schematic** is shown below:

Figure 4.10: Analysis of a Composite Doubly-Curved Specimen and Metal Grips Modeled with Mechanical Application

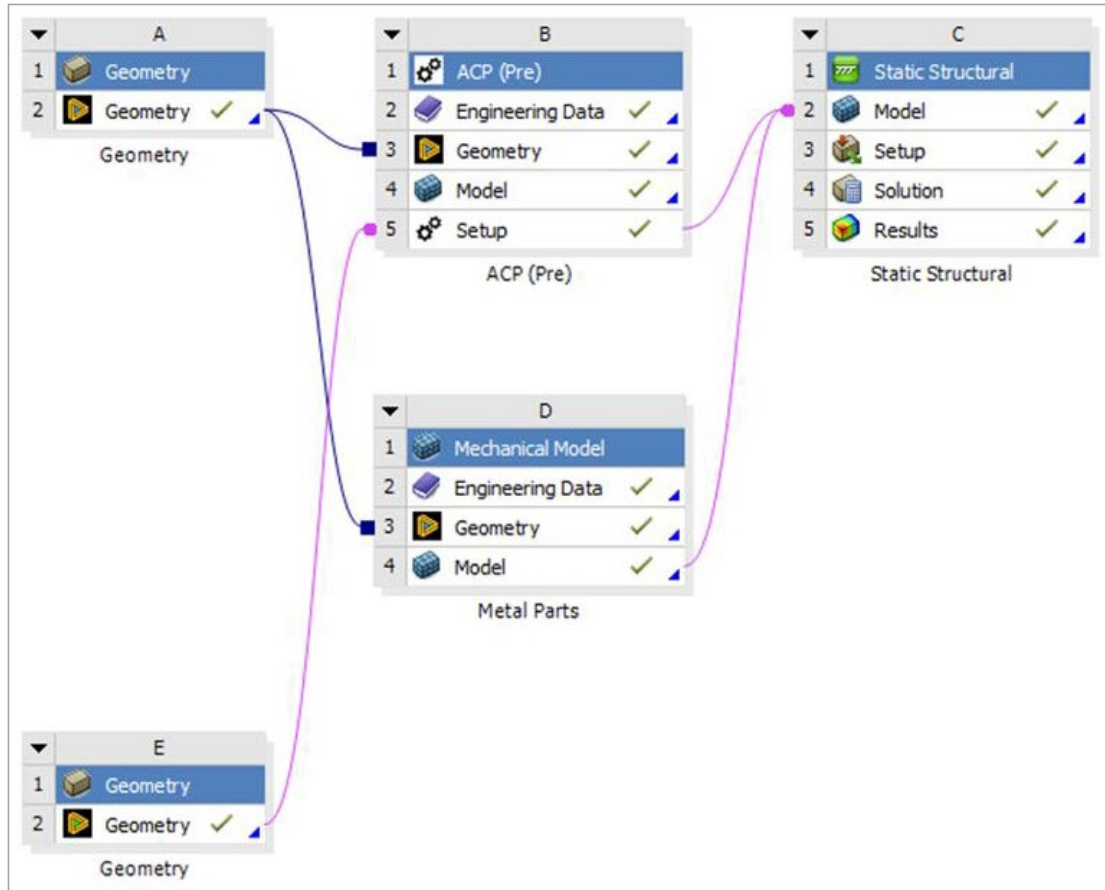

In this example, the geometry consists of one layered solid specimen and two metal grips. The link between **ACP (Pre) (B5)** and **Static Structural (C2)** only transfers the generated layered solid element model. The link between the **Mechanical Model (D4)** and **Static Structural (C2)** transfers all metallic parts. The connections, boundary conditions, and all other preprocessing definitions can be defined in **Setup (C3)** as usual. The global solution and postprocessing can be determined and analyzed in the Workbench Mechanical application.

Figure 4.11: One Layered Solid Specimen and Two Metal Grips in Mechanical Model

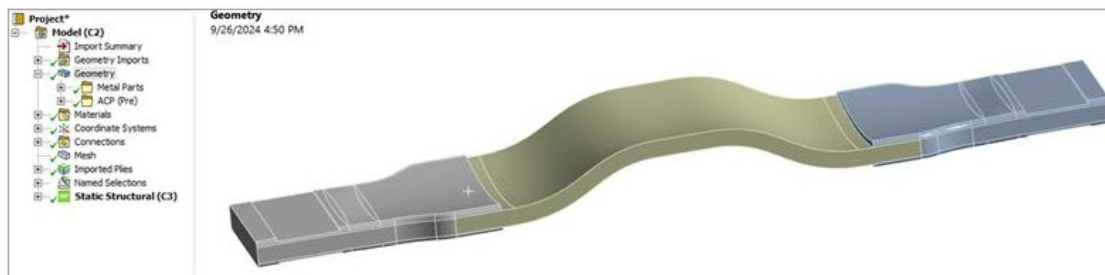

Link with Mechanical APDL Application

Two composite components — a plate and a t-joint — serve as an example for the workflow procedure in the Mechanical APDL application. A **Project Schematic** is shown here:

Figure 4.12: Analysis of Composite Plate and T-joint Modeled with the Mechanical APDL Application

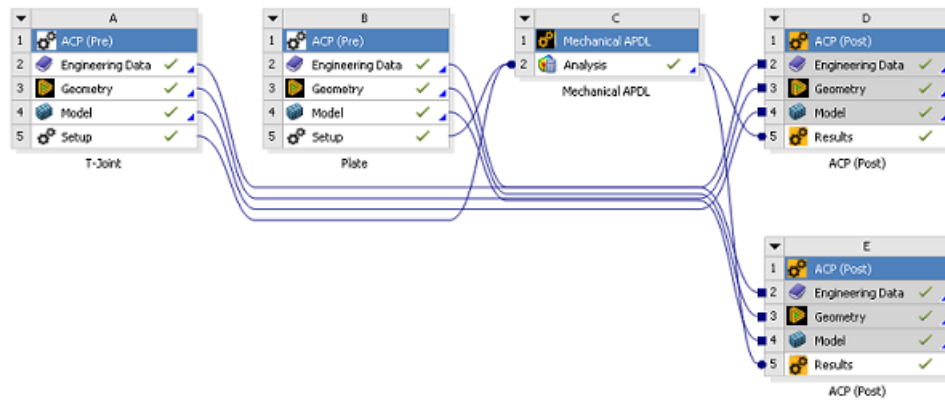

The proper sequence of connecting the system always begins with connecting an **ACP (Pre)** component first. In this case, it is not important because both inputs are **ACP (Pre)** solid models.

In the Mechanical APDL component the boundary conditions, loads and all other preprocessing definitions can be defined through APDL macros. These macros can be linked with the **Mechanical APDL** cell which will be integrated in the automatic update functionality of Workbench. A macro file can be added to the component through the right-click context menu (see figure below). **Add Input File...** appends the APDL running sequence with an additional macro. Check the order of the files of the **Mechanical APDL** component. The macros should be listed after the **Solid Model Process Setup** file(s).

Figure 4.13: Add Reference File

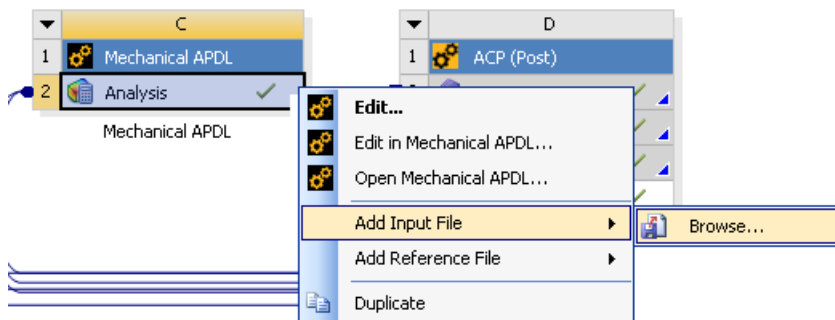

Figure 4.14: List of Used Files and Their Order in Mechanical APDL

Outline of Schematic C2: Analysis		
	A	B
1		Step
2	Launch ANSYS	1
3	Process "Setup"	2
4	Process "Setup"	3
5	Process "run_T_joint.mac"	4

Multiple Parts (Adding Other Systems)

It is possible to add multiple components to one analysis system: two composite parts or a composite part connected to two isotropic parts, for example.

4.2.3. Postprocessing

Global Postprocessing

In general, the global solution of all parts can be viewed in the Workbench Mechanical or Mechanical APDL applications. Analyzing the results of a multi-part assembly considering solid bodies is also possible in the Mechanical software. Specifically, the results are accessible directly in the analysis system, which must be associated with an ACP (Pre) system. The postprocessing functionality for solid models of ACP enables the mapping of ply-wise results onto the reference surface of the solid model. This functionality ensures that failures occurring inside the laminate can be observed and investigated.

Mechanical Application Postprocessing

For postprocessing in the Mechanical application, see [Postprocessing of a Composite Solid Model in the Mechanical User's Guide](#).

4.3. Analysis Using Variable Material Data

This simple example of a race car nose and wing demonstrates a possible workflow for composite analyses using variable material data, ACP draping simulation, and temperature dependence. Variable material data is used to simulate incomplete curing of the composite material in the model. Note that the wing geometry, composite lay-up, and material data are fictitious and should not be used in any real world analysis or application.

The following figure shows the Workbench setup. **Cell D (External Data)** contains the results of a Fluent analysis which provides the surface pressure distribution on the race car nose and wing. The composite lay-up, draping, and incomplete curing field are defined in **ACP-Pre** in **cell A**. **Cell E (External Data)** defines the temperature field. The structural effect of the airflow around the race car nose and wing are analyzed in **cell B (Static Structural)**, which also contains the failure analysis of the composite structure.



The model used in this example analysis is available by .

A general overview of using variable material data can be found in [Variable Material Data in Composite Analyses](#) (p. 303).

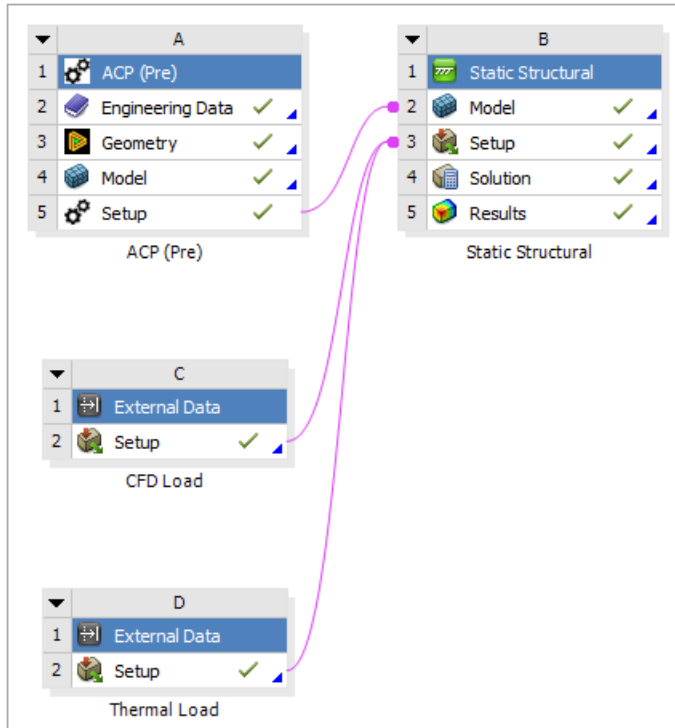
Figure 4.15: Race Car Setup in the Workbench Application

4.3.1. Workbench Application Engineering Data: Set-Up Variable Data

Variable data for composite materials are configured in **Engineering Data**. The following properties can be functions of up to nine field variables:

- Density
- Elasticity parameters
- Stress limits
- Strain limits

Temperature, Shear Angles and Degradation Factor are predefined field variables. User-defined field variables can also be created. In this example, the effect of incomplete curing across the parts is modeled. As a first step, the field variable **Incomplete Curing** is defined and specified as dimensionless. A value of 1.0 indicates perfect curing while a value of 0.0 indicates that no curing took place.

Figure 4.16: Predefined and User-Defined Field Variables in Engineering Data

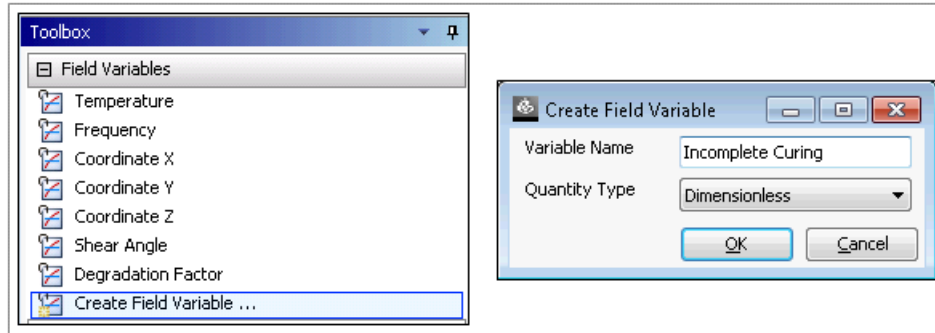

In the next step, the field variables are assigned to the material properties. Make the elasticity parameters of the Epoxy_Carbon_Woven_230GPa_Prepeg material a function of **Temperature**, **Shear Angle**, and **Incomplete Curing**. To accomplish this, select the material and then select the **Orthotropic Elasticity** property. Double-clicking a field variable assigns it to the **Orthotropic Elasticity** property. Fill the table for the **Orthotropic Elasticity** property by manually entering values or by importing a [CSV file](#).

Figure 4.17: Assigning a Field Variable to Material Property

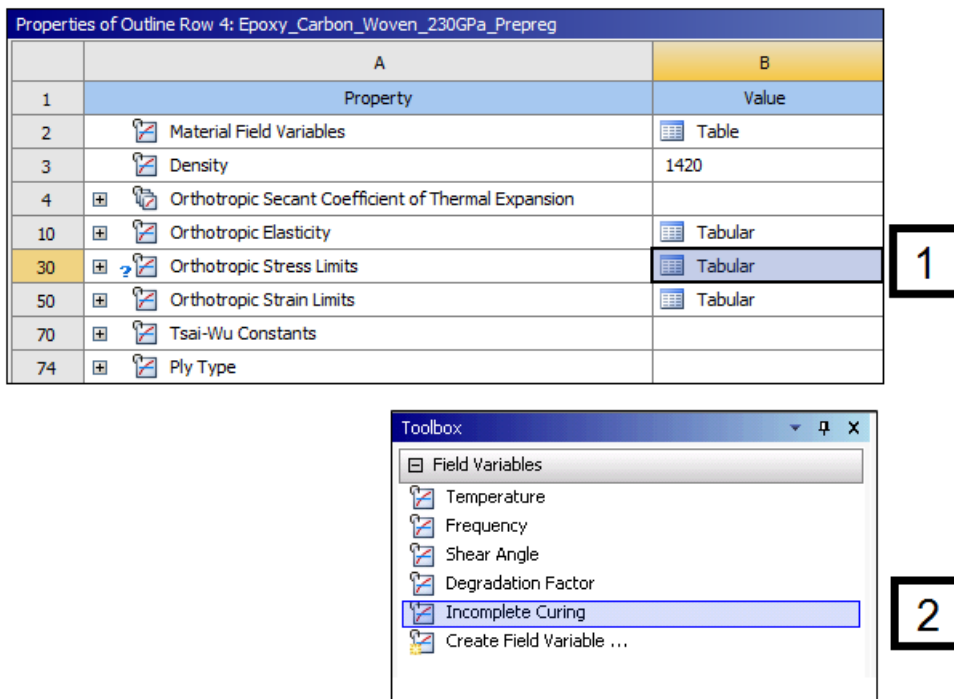

Figure 4.18: Populating the Tabular Material using the CSV Interface

Table of Properties Row 10: Orthotropic Elasticity					
	A	B	C	D	E
1	Incomplete Curing	Shear Angle (degree)	Temperature (C)	Young's Modulus X direction (Pa)	Young's Modulus Y direction (Pa)
2	0.5	0	20	5.8E+10	1.4E+10
3	0.5	10	60	4.77E+10	1.08E+10
4	1	0	*		
5	1				
*					

During finite element computations and postprocessing, the effective material properties are interpolated from these tables based on the local field variables state. The interpolation scheme can be controlled when selecting **Interpolation Options**. When selecting the **Material Field Variables** property, the unit, default data, lower, and upper limit can be set. The software suggests program controlled values for some of the options. The default data defines the assumed state of the field variable, if it is not specified in the model.

In this way, you can have full material specifications in Engineering Data, but only use a subset of the specified dependencies during the simulation. For more details, see [ACP \(Pre\): Define Fields for Shear Angle, Degradation Factor, and User-Defined Field Variables](#) (p. 324).

Figure 4.19: Setting Interpolation Options

Properties of Outline Row 4: Epoxy_Carbon_Woven_230GPa_Prepeg					
	A	B	C	D	E
1	Property	Value	Unit		
2	Material Field Variables	Table			
3	Density	1420	kg m^-3		
4	Orthotropic Secant Coefficient of Thermal Expansion				
10	Orthotropic Elasticity	Tabular			
11	Interpolation Options	Table			
12	Young's Modulus X direction: Scale	1			
13	Young's Modulus X direction: Offset	0	Pa		
14	Young's Modulus Y direction: Scale	1			
15	Young's Modulus Y direction: Offset	0	Pa		
16	Young's Modulus Z direction: Scale	1			
17	Young's Modulus Z direction: Offset	0	Pa		
18	Poisson's Ratio XY: Scale	1			
19	Poisson's Ratio XY: Offset	0			
20	Poisson's Ratio YZ: Scale	1			
21	Poisson's Ratio YZ: Offset	0			

Table of Properties Row 2: Epoxy_Carbon_Woven_230GPa_Prepeg Field Variables					
	A	B	C	D	E
1	Variable Name	Unit	Default Data	Lower Limit	Upper Limit
2	Temperature	C	22	Program Controlled	Program Controlled
3	Shear Angle	degree	0	Program Controlled	Program Controlled
4	Incomplete Curing		1	Program Controlled	Program Controlled

Table of Properties Row 10: Orthotropic Elasticity			
	A	B	C
1	Algorithm Type	Normalize	Cache
2	Linear Multivariate	<input checked="" type="checkbox"/>	<input checked="" type="checkbox"/>

4.3.2. ACP (Pre): Define Fields for Shear Angle, Degradation Factor, and User-Defined Field Variables

ACP (Pre) provides the ability to set up fields for Shear Angle (draping), Degradation Factor, and all user-defined field variables for a complete composite model. The Shear Angle can be defined as a result of ACP draping simulation or imported via [look-up tables \(p. 107\)](#). Degradation Factor and user-defined field variables can be defined per shell or solid element as an interpolation result from a scalar look-up table column. For example, you can define the state of a field variable at various spatial positions in a .CSV file and import it as a 3D [look-up table \(p. 107\)](#). By creating a [Field Definition \(p. 165\)](#) object in ACP-Pre, you can assign the imported scalar look-up table column to the field variables previously specified in Engineering Data and scope them to part of your model, even to single Modeling Plies. See the [Element- or Layer-wise Field Definition \(p. 303\)](#) section.

The application automatically considers the result of the draping simulation when evaluating the effective material properties in downstream analyses and postprocessing.

Figure 4.20: Draping Results

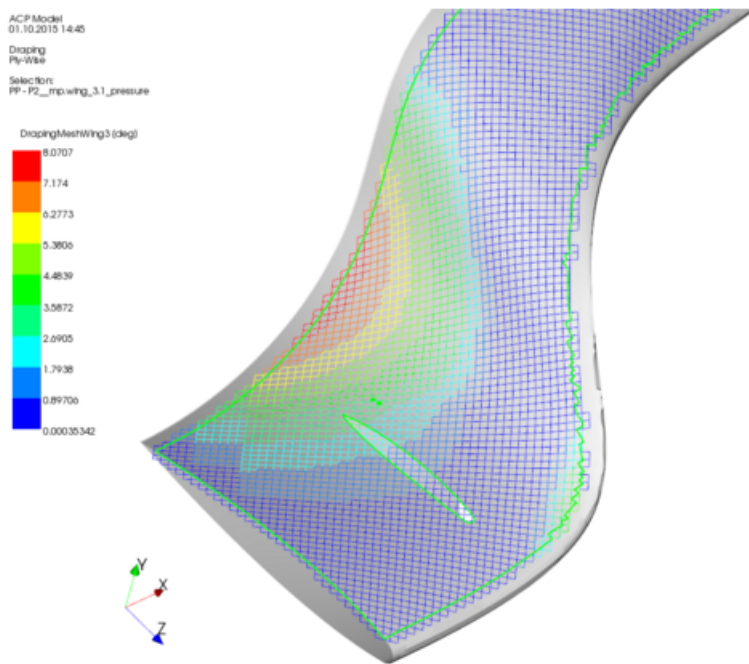

Use look-up tables to define scalar fields on composite models. The interpolation result from the look-up tables can be visualized using Scalar Look-up Table plots and the Field Definition objects in turn can be visualized using Field Definition plots. The following figure shows Curing Degree over the race car nose and front wing (upside down).

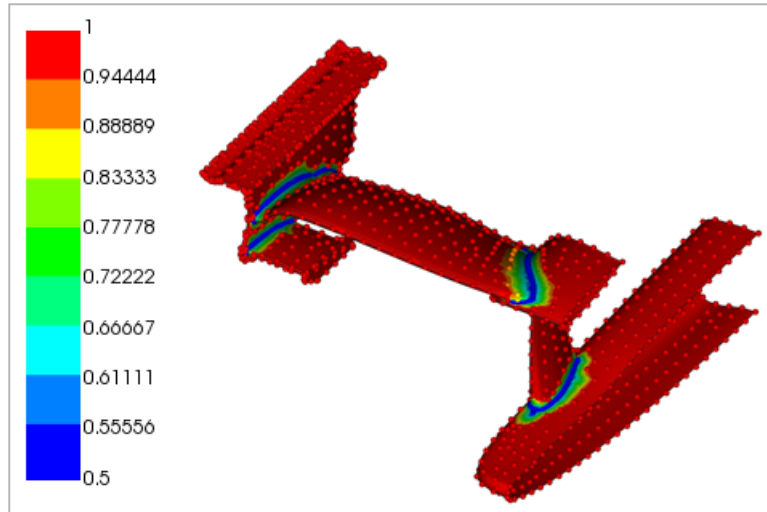
Figure 4.21: Distribution of the Curing Degree (Scalar Look-Up Table Plot)

To activate a 3D look-up table as the Curing Degree field, you need to assign it in the ACP (Pre) by setting up a respective Field Definition. Note that you must maintain unit consistency between the Look-up Table column values and the active unit system in the Mechanical application (units of the look-up table column are not converted to the active unit system). See the [Field Definitions \(p. 165\)](#) section for additional details. The following figure shows this process:

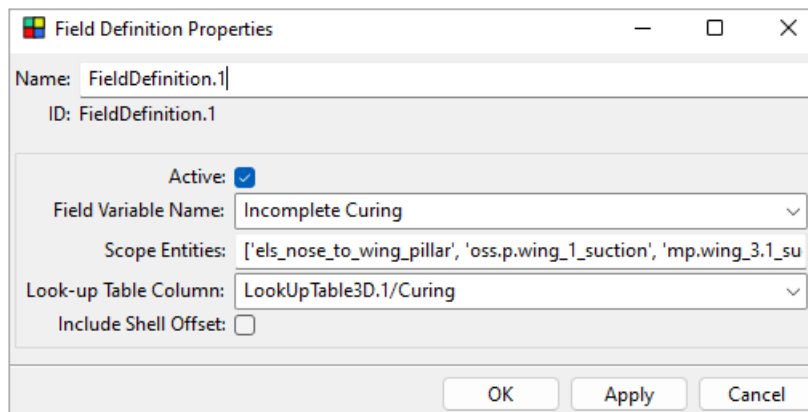
Figure 4.22: Activating a Look-Up Table to Define Curing per Modeling Ply (Layer-Wise)

4.3.3. Mechanical, Thermal Loading, and External Data

Thermal loading through the Temperature field variable can be accomplished by:

- Transient Thermal analysis
- External Data analysis component in Workbench
- Setting the environmental or part temperature directly in Mechanical

The resolution of the temperature field is per element node.

Figure 4.23: Using External Data to Define Temperature Field

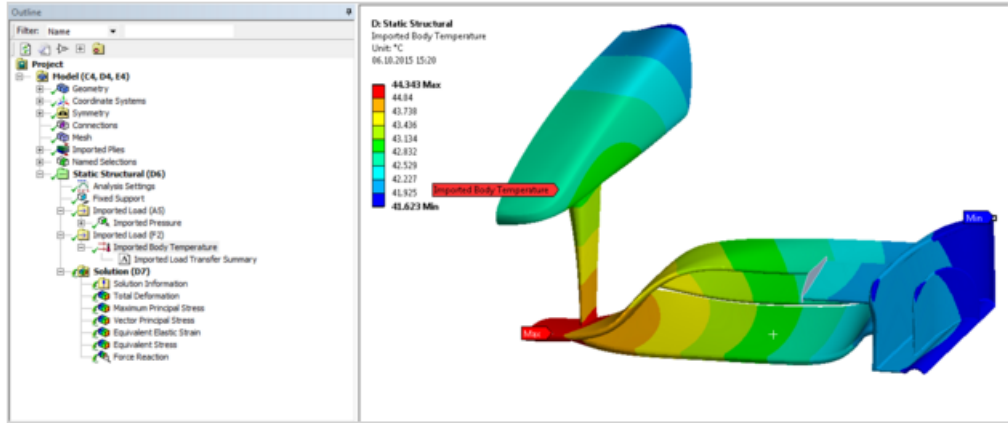

4.3.4. Postprocessing in Mechanical Application: Analysis Effect of Variable Data

Stress and strain limits can be defined in Engineering Data as a function of field variables. These dependencies are fully reflected in the Mechanical application when evaluating respective failure criteria.

The following figure shows inverse reserve factor plots of combined Maximum Stress, Hashin, Face Sheet Wrinkling, and Core Failure failure criteria. The structure is viewed from the bottom. On the left is the result with constant material properties, and on the right the effect of Temperature, Shear Angle, and Incomplete Curing is shown. The color bar ranges are the same. It is clearly visible that the IRFs are much higher within the gold square.

Figure 4.24: Inverse Reserve Factor (Constant Material Data on the Left; Variable Material Properties on the Right)

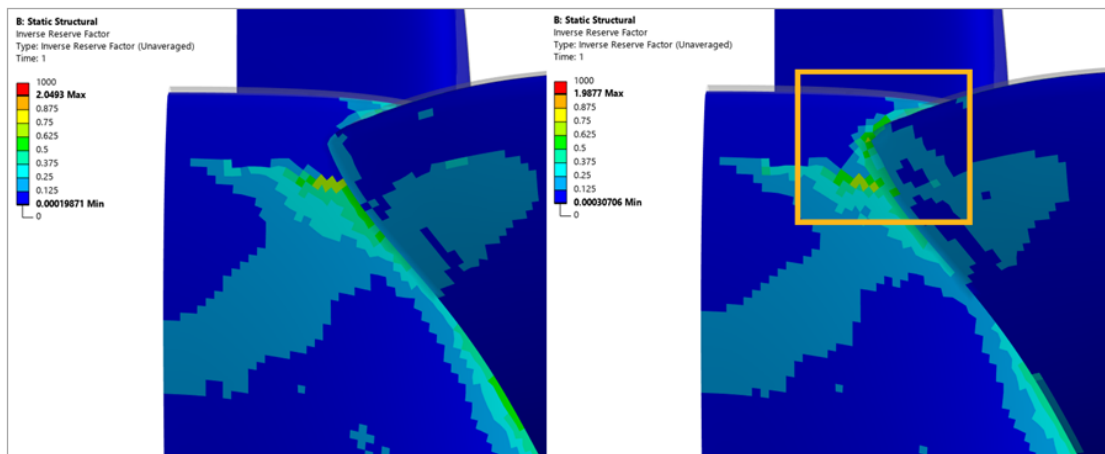

4.4. Analysis of a Mapped Composite Solid Model

In the case of thick composites, the layered shell theory can cause significant errors in the obtained results. In some cases, it is necessary to work with 3D models, also referred to as Solid Models. ACP has the feature to map the ACP Composite Definitions onto external solid meshes.

In this section, the workflow of modeling mapped composite solid meshes is outlined. To a large extent the workflow is the same as that of a [standard solid model \(p. 314\)](#), except there is one main difference: The solid mesh is imported via Mechanical Model and not generated in ACP (Pre) itself. See [Solid Modeling \(p. 48\)](#).

An exemplary complete workflow contains these steps:

1. **Preprocessing:** Define the Composite Definitions in ACP (Pre) as described in the [Analysis of a Composite Solid Model \(p. 314\)](#) section.
2. **Mapping of the Composite Definitions:** Import the external volume mesh and configure the Imported Solid Model object in ACP (Pre).
3. **Analysis:** Transfer the solid composite data to a [downstream analysis \(p. 316\)](#) (structural, modal, etc.).
4. **Postprocessing:** Run the composite failure analysis for the composite structures in Mechanical.

This example examines how a full cross-section composite spring can be modeled by mapping Composite Definitions from ACP (Pre) onto an existing mesh.

 You can download the Workbench archive for this example here:

Tip:

A video that demonstrates this capability [can be found here](#).

Geometry and the Lay-Up

The geometry and the lay-up of the spring are shown in the figure below. The lay-up can be split into three sections. The four reinforcement plies at the outer surface consist of a woven fabric, and the total thickness of this section is 1 mm. The material orientation of the plies is alternating, $\pm 45^\circ$. The next ply is a 2 mm thick isotropic core material. And a roving (carbon UD) fills the center section of the spring where the fibers are along the extrusion direction (helix) of the spring.

Figure 4.25: Geometry and Lay-Up of the Composite Spring

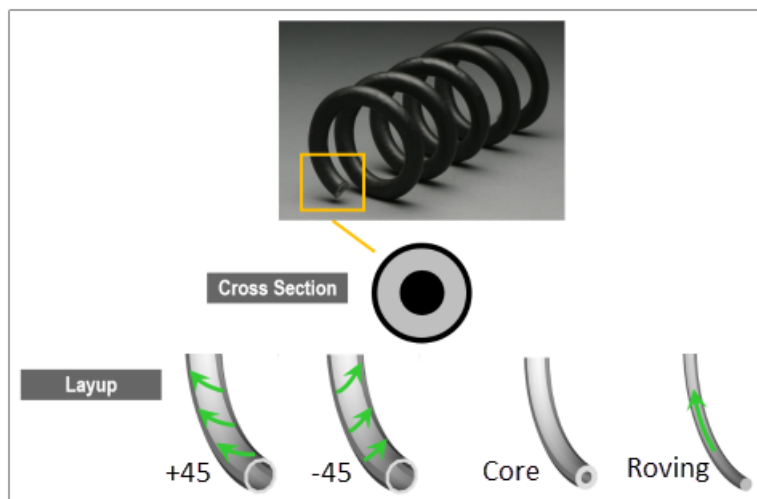

4.4.1. Transfer External Solid Mesh to ACP (Pre)

The lay-up mapping feature transfers the lay-up definition of ACP (Pre) onto an external solid mesh that was generated outside ACP (Pre). This section describes how the solid mesh is transferred to ACP (Pre), system C. This includes preparing the geometry and meshing as well as linking the Workbench systems.

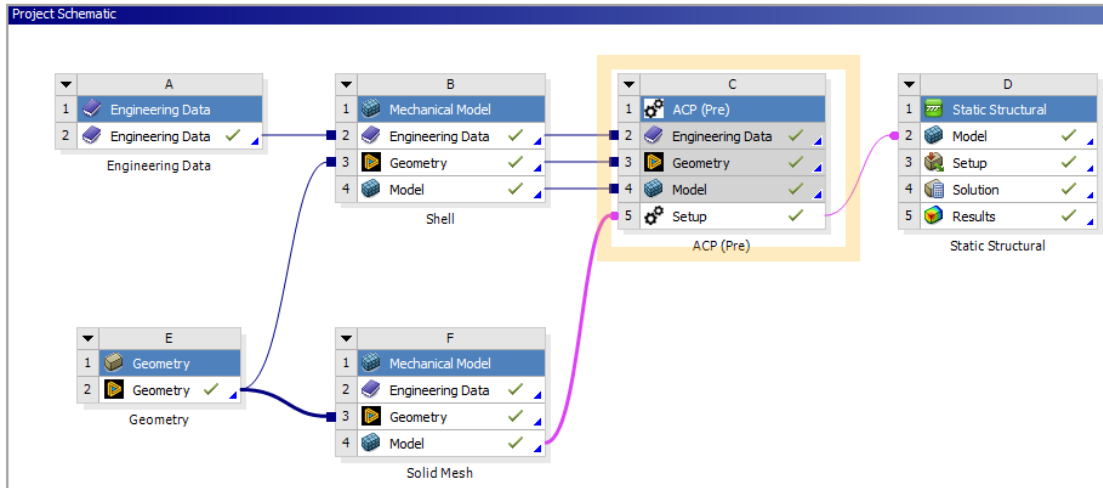

4.4.1.1. Geometry

The entire geometry is prepared in SpaceClaim (system E) and contains both the shell reference surface and the solid. Therefore, the geometry is split into two parts in the subsequent workflow. The shell surface is used to specify the Composite Definitions in ACP (Pre) and is passed to system B and later to ACP (Pre), system C. The volume of the spring is required to generate the solid mesh in the Ansys Mechanical software and is passed to another Mechanical model (system F).

Note:

SpaceClaim is no longer included in the unified installer. Ansys recommends using Discovery Modeling to create geometries, or its alternative DesignModeler.

Figure 4.26: Complete Project Schematic in the Workbench Application

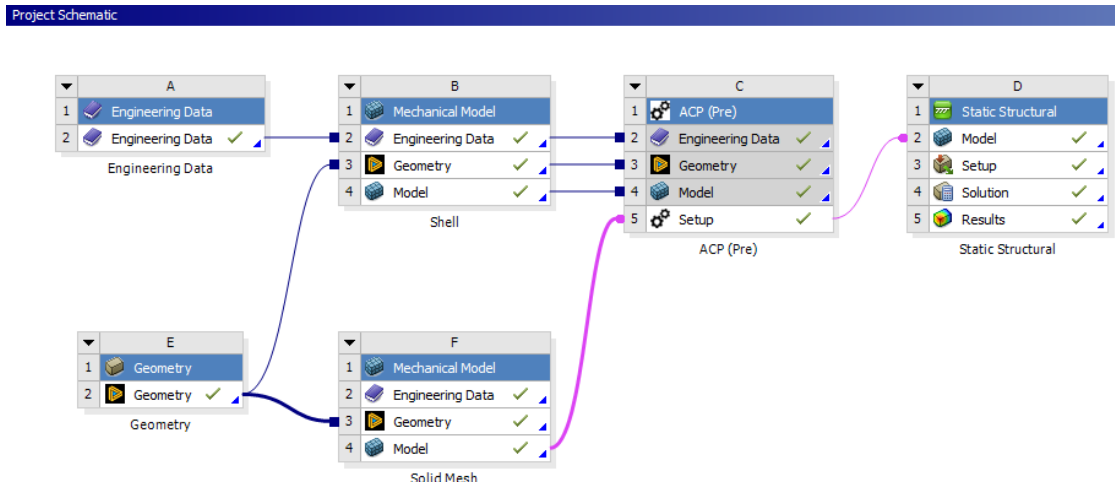

To achieve an accurate FE model of the solid with the correct material assignments, the solid geometry is split into two bodies: the **Tube** and the **Roving**. This ensures that, later, the reinforcement plies and UD roving can be mapped accurately onto their intended region and that the volume contents of the materials are correct. These bodies are passed to ACP (Pre) (the connection between system F and C) as Named Selections. The figure below shows the geometry with the two solid bodies and the Named Selections.

Figure 4.27: Mechanical Application Model F4 with the Bodies Roving and Tube

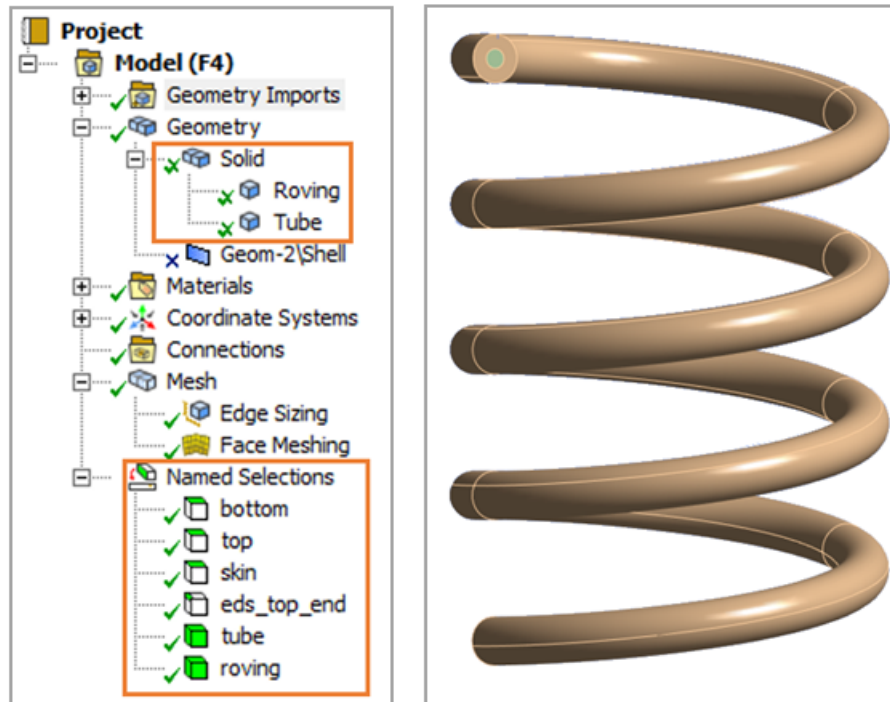

Also, other Named Selections are added which will be used to apply the boundary conditions in analysis system D. It is important that all geometries except the solid are suppressed in system F so that the data transfer from F4 (the Mechanical application model) to C5 (ACP (Pre)) contains only the solid mesh.

4.4.1.2. Meshing

The lay-up mapping algorithm in ACP (Pre) is currently designed for structured meshes where degenerated elements can be filled with an orthotropic material. Therefore, the solid mesh that gets lay-up data from ACP (Pre) should mainly consist of structured elements (hex) which support layered section data. In this example, it is the solid Tube.

The mesh of the inner body, the Roving, must meet fewer requirements because the filler option will be used in ACP (Pre) to assign the UD material to this body. The elements, then, are handled as homogeneous elements instead of layered elements which relaxes the requirements on the mesh. The figure below shows the mesh of the solid geometry with a mapped mesh and Sweep method in the outer region (Tube).

Figure 4.28: Detail View of the Final Solid Mesh with Hex Elements only in the Outer Body

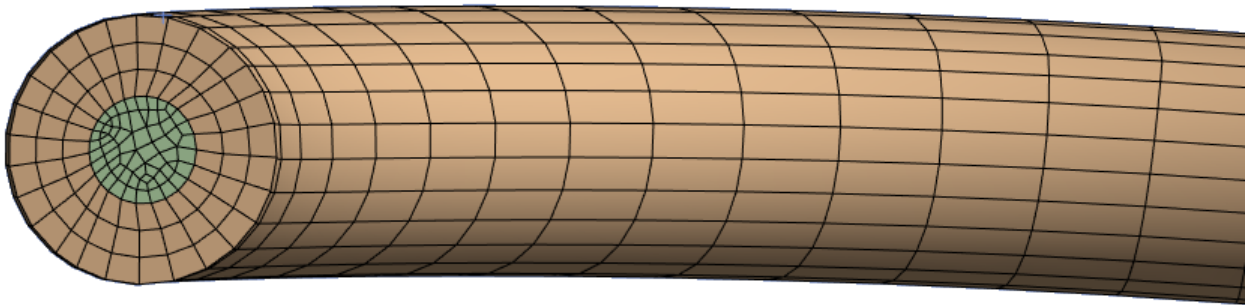

4.4.1.3. Linking the Systems in the Workbench Application

The solid mesh is passed to the ACP (Pre) system by transferring F4 to C5. (Simply drag-and-drop F4 onto C5.) This connection will create an Imported Solid Model object in ACP (Pre) which contains the solid mesh and Named Selections.

Figure 4.29: Mesh Features and Solid Mesh with the Inflation Layers and Roving Cross Section

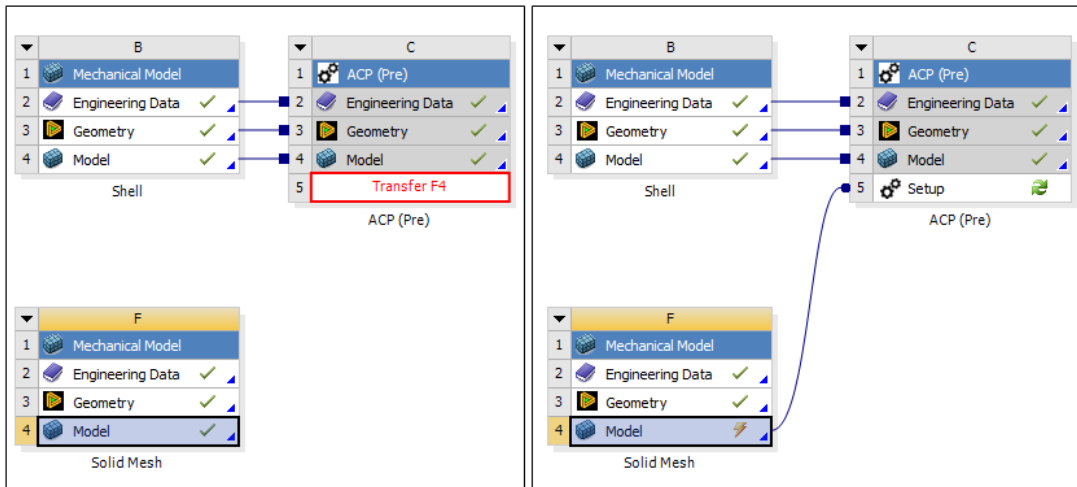

4.4.2. Lay-Up Mapping in ACP (Pre)

An [Imported Solid Model](#) (p. 208) object is automatically generated in ACP (Pre) as soon as a Mechanical application model is linked to an **ACP Setup** component. The file format, unit system, and file path are automatically set and cannot be changed.

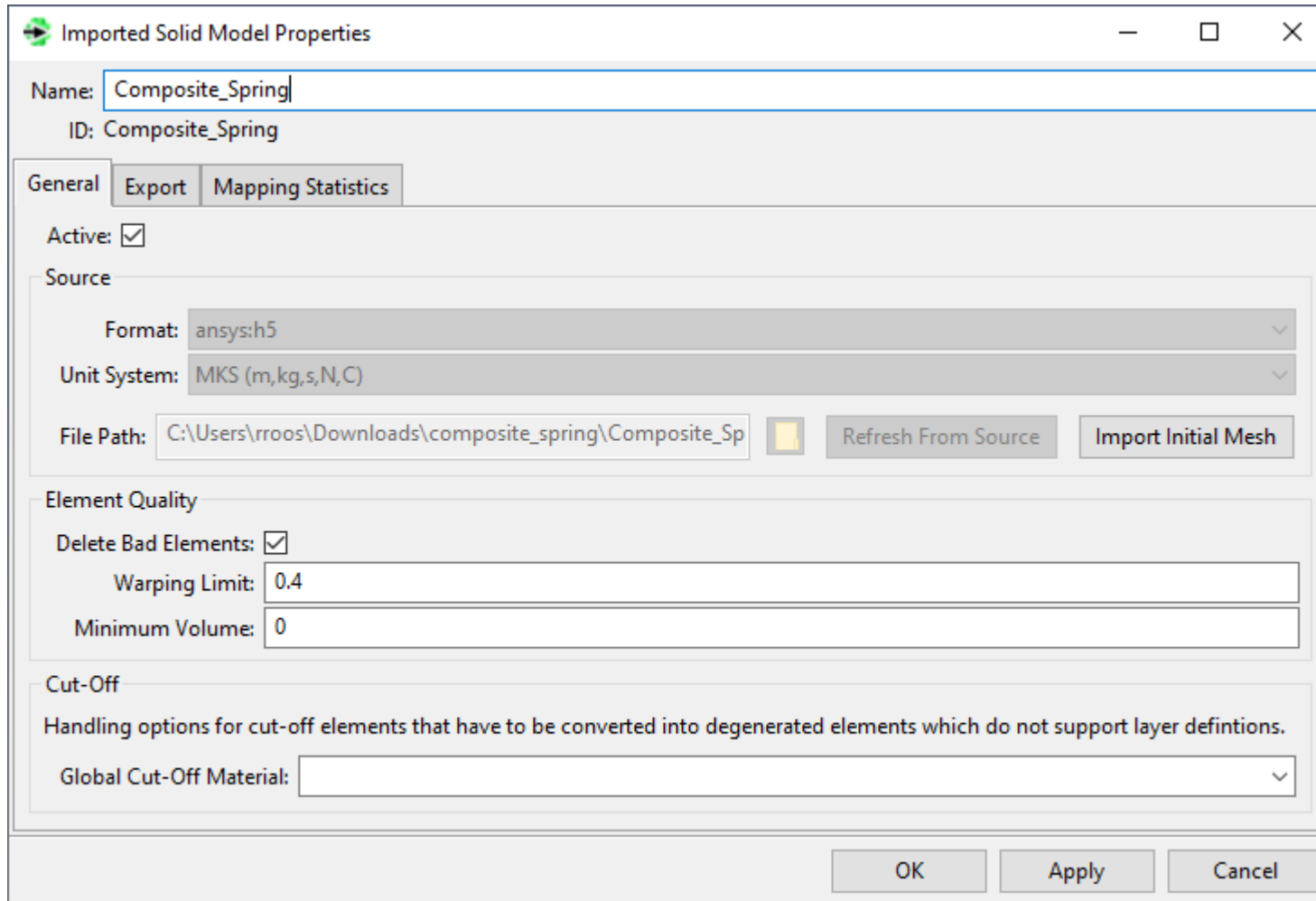
Figure 4.30: Imported Solid Model Properties Dialog

The Imported Solid Model object also contains the Named Selections which were generated in the upstream component. They appear as **Mesh Components** as shown below. You can see the mesh of the Imported Solid Model (even before you define any settings for the mapping) by right-clicking **Composite_Spring** and selecting **Import Initial Mesh** from the context menu.

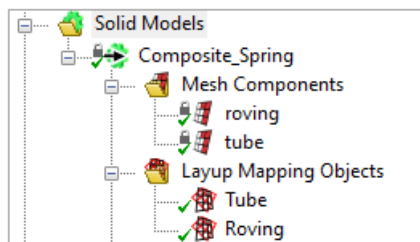

In this example, the lay-up mapping is split into two pieces, one for the Tube and one for the Roving. So, a **Lay-up Mapping Object** is generated for each of these regions

The source plies for the region **Tube** are the woven and core plies which are all defined in the Modeling Group **Laminate**. The configuration of the **Lay-Up Mapping Object** is shown below.

Figure 4.31: Figure: Lay-up Mapping Definition of the Mesh Component Tube

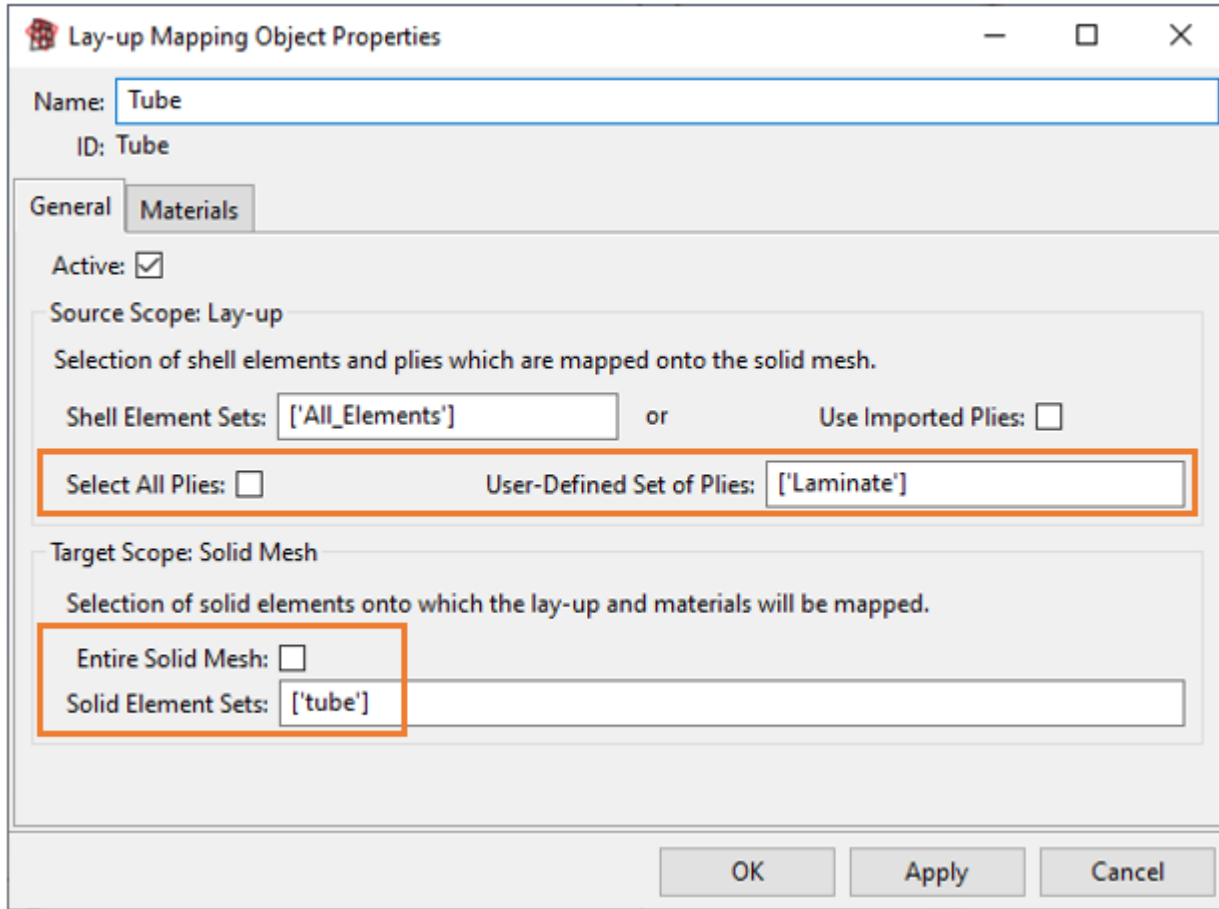

The filler option is used to assign the UD material to the roving mesh component. The filler option is activated by passing an empty list of plies and defining a filler material and orientation. In the figure below, the filler options for the roving are shown– the **General** options (A) and the **Materials** options (B).

Figure 4.32: The Filler Options for the Roving

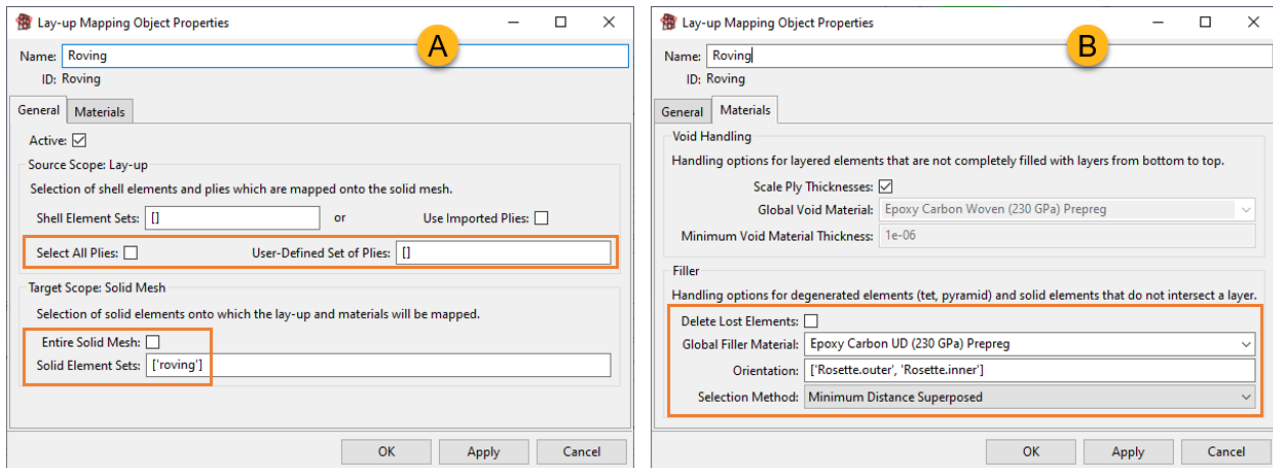

The mapped plies and generated materials are displayed under the **Analysis Plies** folder of the Imported Solid Model. You can use these entities to plot ply-wise data such as thickness and fiber directions.

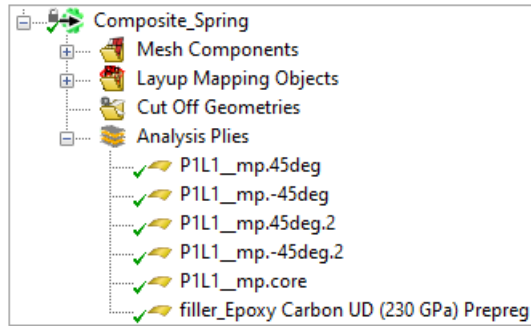

The figures below show the final solid mesh with mapped plies and UD materials. The first figure shows the first ply on the solid mesh, its thickness and material orientations.

Figure 4.33: Filler Elements and Fiber Directions

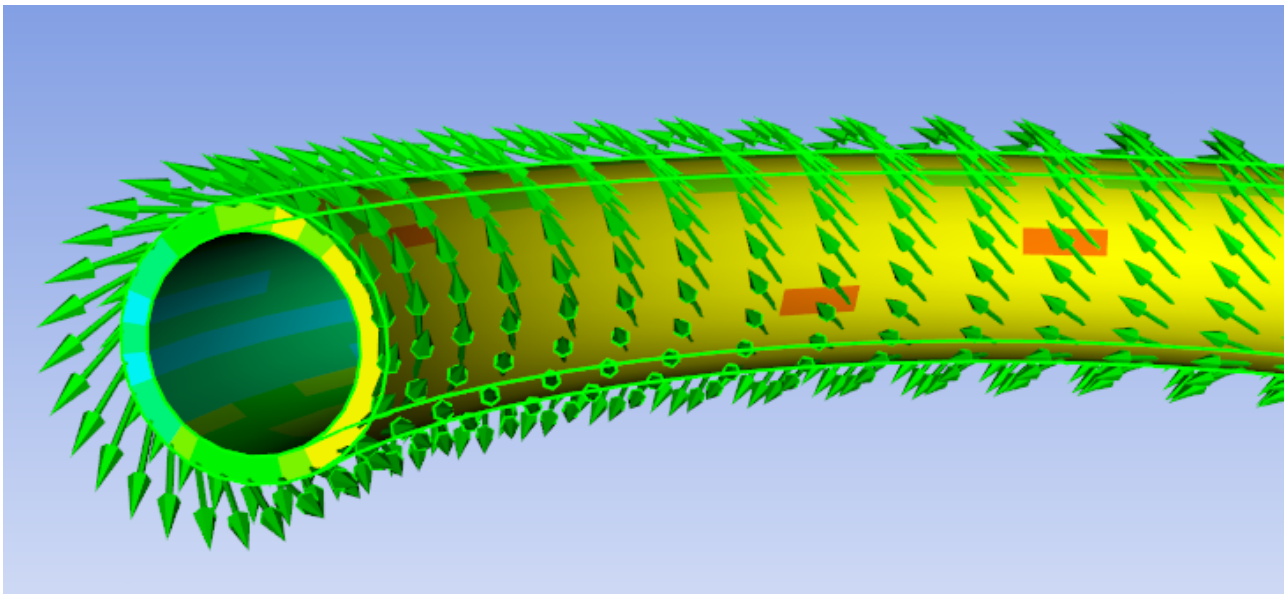

The assignment of the UD material is shown in the next figure. It shows that the orthotropic material (UD carbon) is perfectly aligned with the extrusion direction of the spring thanks to the selected Rosettes and Selection Method.

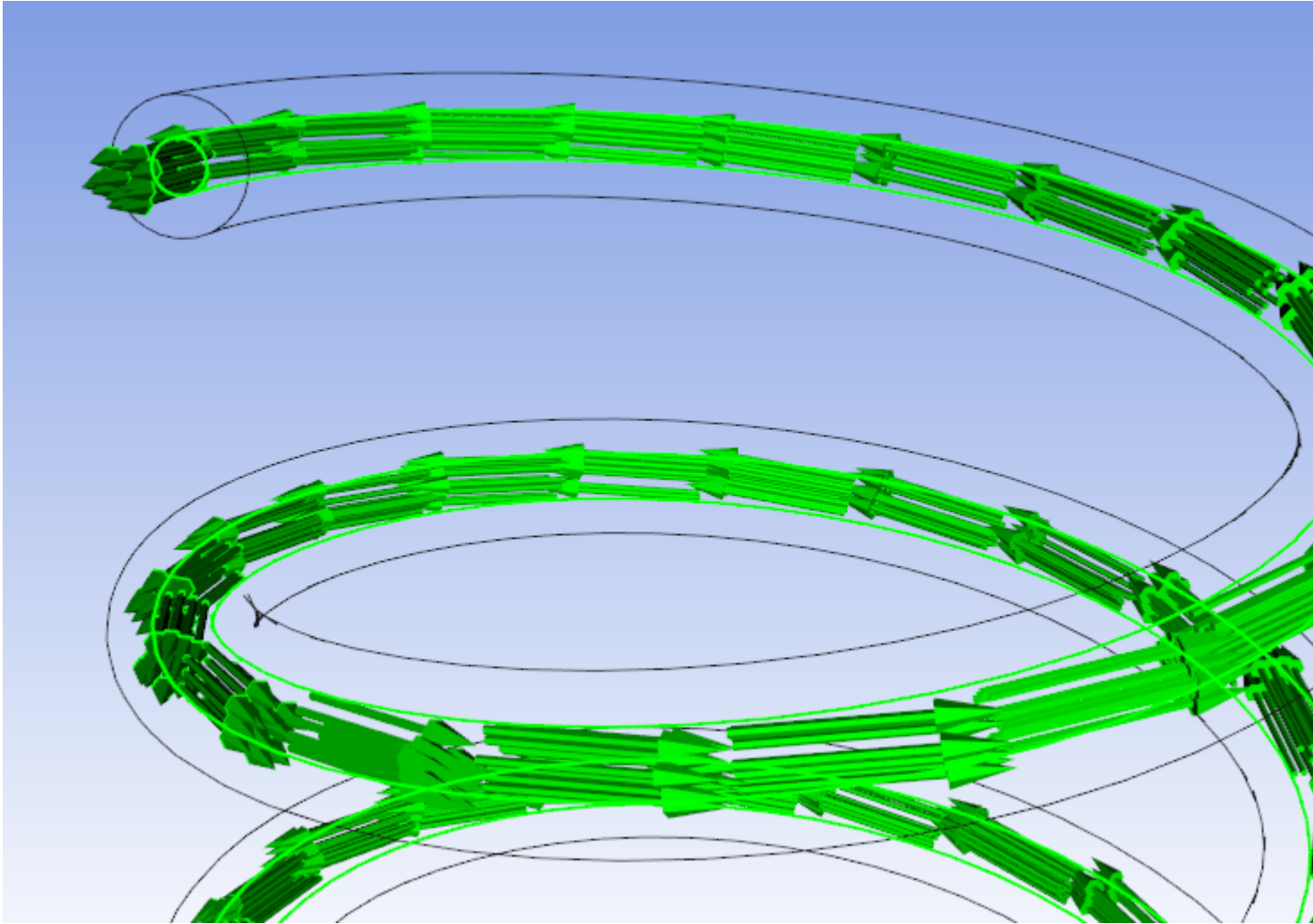
Figure 4.34: Using the Filler Option for the Roving

4.4.3. Analysis of A Mapped Composite Model

The Imported Solid Mesh is passed to a structural system to simulate a compression load case until the surfaces of the helix are in contact. See system D in [Figure 4.27: Mechanical Application Model F4 with the Bodies Roving and Tube](#) (p. 329).

Once the solution is up-to-date, the composite solid model can be postprocessed in the Mechanical application as shown in the figure below A. **Composite Failure Tool** is set up to address the different material types (woven and UD fabrics, and core material). This can be achieved by selecting for example the Max Stress, Puck, and Core Shear failure criteria.

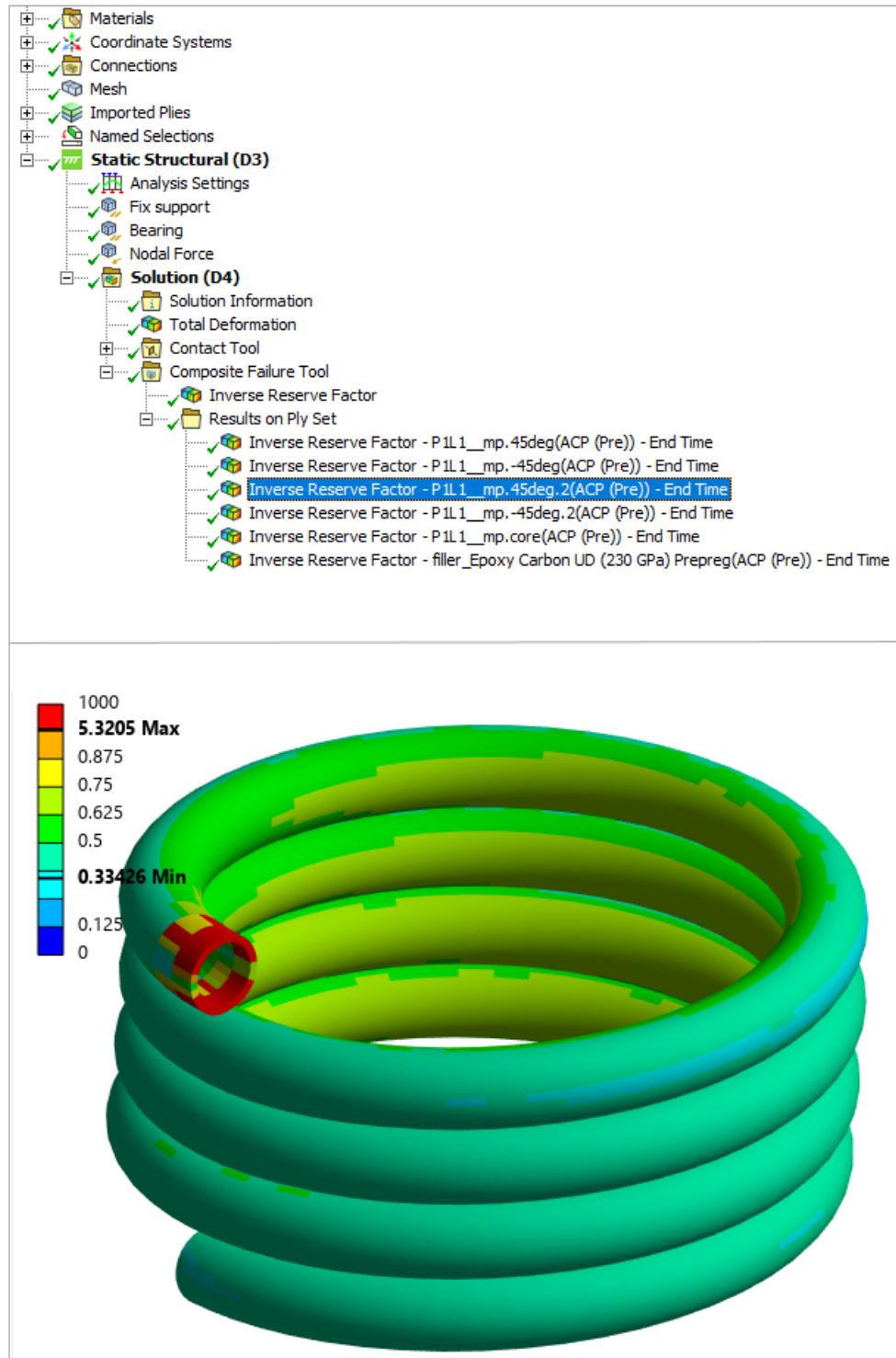
Figure 4.35: Ply-wise Failure Analysis

4.5. Shear Dependent Materials in Composite Analysis

This example demonstrates a possible workflow for composite analyses using homogenized material data (with shear dependency) for a woven composite provided by Material Designer. To this end, a

simple model consisting of an inflated half-sphere is considered. The effect of draping simulation combined with shear-dependent material properties in the ACP application will be shown.

The following figure shows the setup in the Workbench application. The material data of a Carbon/Epoxy woven fabric are computed by the Material Designer software (systems A and B) as illustrated in the **Material Designer Woven Composite Tutorial**. The composite lay-up and draping options are defined in ACP (Pre) (system C). Finally, the structural effect of an internal pressure load is analyzed in system D (Static Structural).

Figure 4.36: Project Setup in the Workbench Application

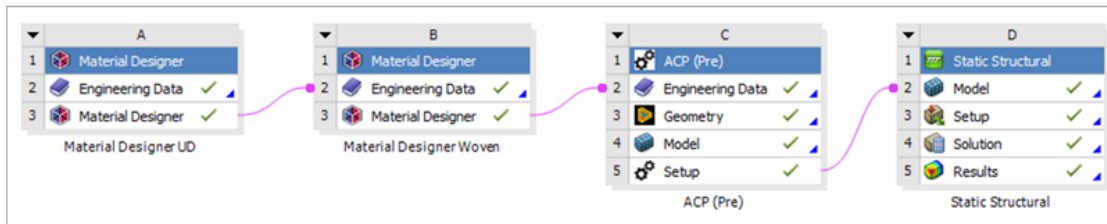

If desired, you can the model used in this example analysis and perform the steps yourself.

Homogenized Material Data





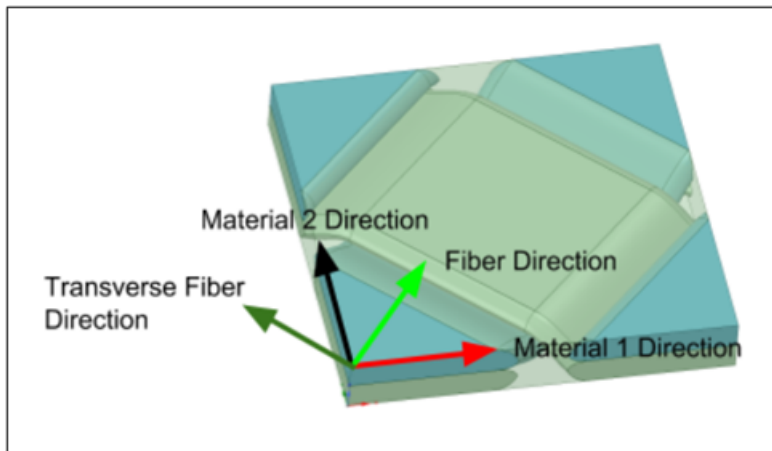



Following the Material Designer software's [Woven Composite Tutorial](#), the homogenized material data for a Carbon/Epoxy woven fabric are generated. In particular, using an RVE whose material directions are aligned with the yarns bisectors, so that the resulting homogenized material remains orthotropic in presence of shear (see [Fabric Fiber Angle \(p. 78\)](#) in the [Material Designer User's Guide](#)).

Figure 4.37: Woven RVE defined in Material Designer Application





We set up two analyses in the Material Designer software (Cell B in the Workbench project): a constant material analysis and a variable one with a shear angle between -30° and 30° as parameter. The resulting materials are then transferred to the Engineering Data component of the ACP system.

Figure 4.38: Materials in the Engineering Data Component of the ACP system

Outline of Schematic C2: Engineering Data		
	A	B C
1	Contents of Engineering Data	 
2	Material	
3	 Epoxy/Carbon Woven	 
4	 Variable Plain woven Matrix/Epoxy Carbon UD	 
*	Click here to add a new material	

Note that the constant material has a constant Fabric Fiber Angle equal to 45°, while the variable material has a shear dependent Fabric Fiber Angle.

Figure 4.39: Shear Dependent Fabric Fiber Angle

Table of Properties Row 25: Fabric Fiber Angle		
	A	B
1	Shear Angle (degree) 	Fabric Fiber Angle (degree) 
2	-30	60
3	-15	52.5
4	0	45
5	15	37.5
6	30	30

Fibers and Material 1 Directions in the ACP Application

In the ACP application, define a ply with a variable woven fabric and a ply angle of 0°.

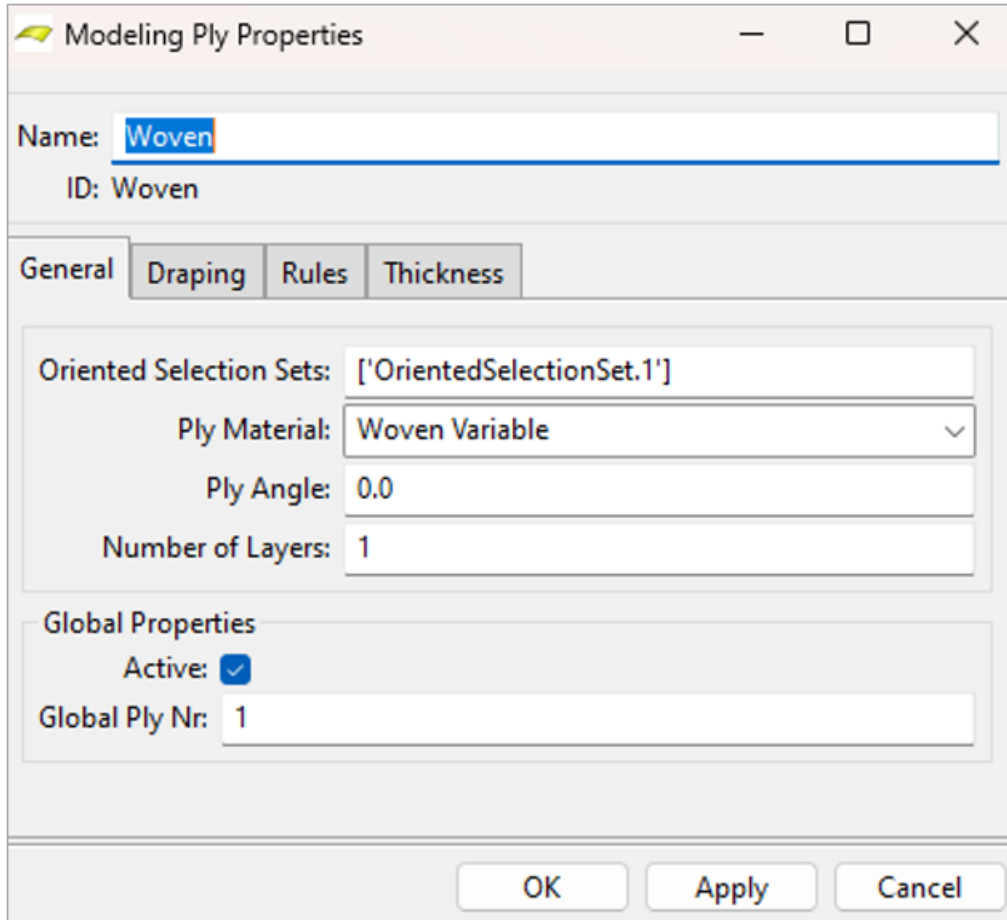
Figure 4.40: Ply Definition

The effect of the Fabric Fiber Angle property can be highlighted by comparing the ply fiber directions with the material 1 direction.

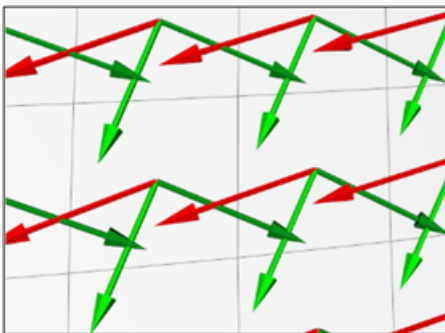
Figure 4.41: Fiber (Light Green), Transverse (Dark Green) and Material 1 (Red) Directions

The material 1 direction identifies the direction in which the material properties are specified. However, the fiber direction is still the nominal modeling direction in ACP, that is, the Ply Angle still defines the orientation of the fibers with respect to the reference direction.

Draping

The Shear Angle can be defined as a result of draping simulation in the ACP application (see [Draping \(p. 279\)](#)).

You can enable the Internal Draping algorithm in the Draping tab of the [Modeling Ply Properties \(p. 142\)](#) dialog.

Figure 4.42: Draping Definition

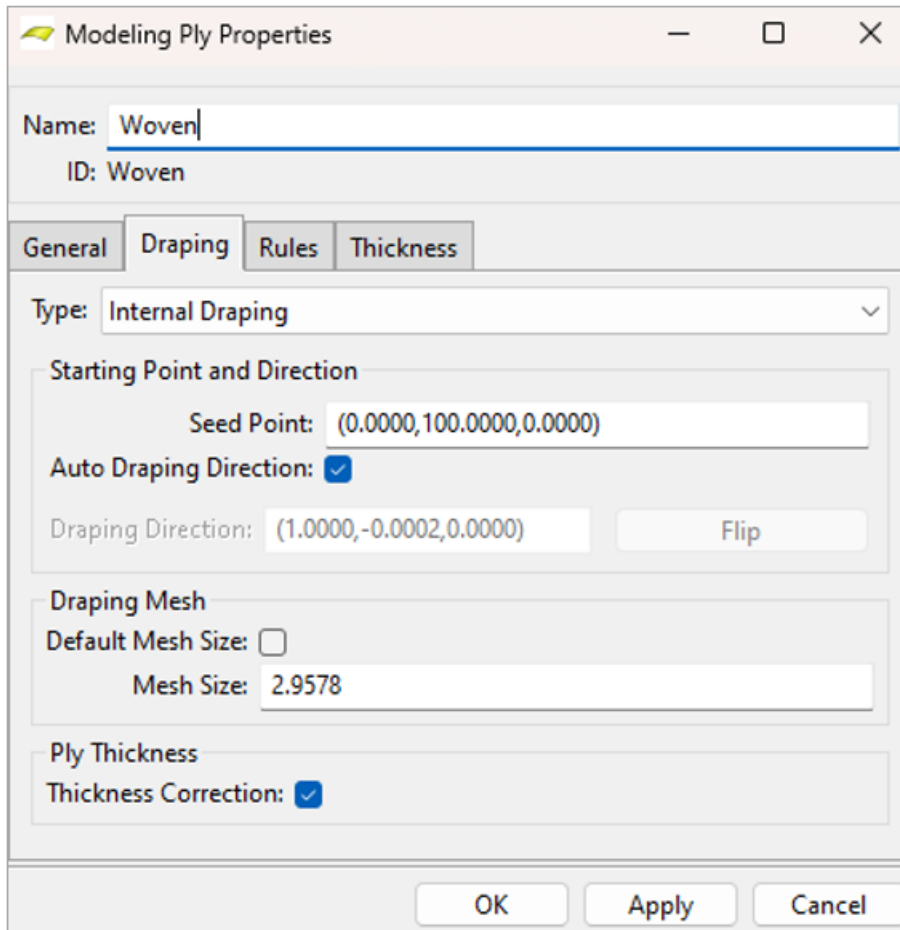
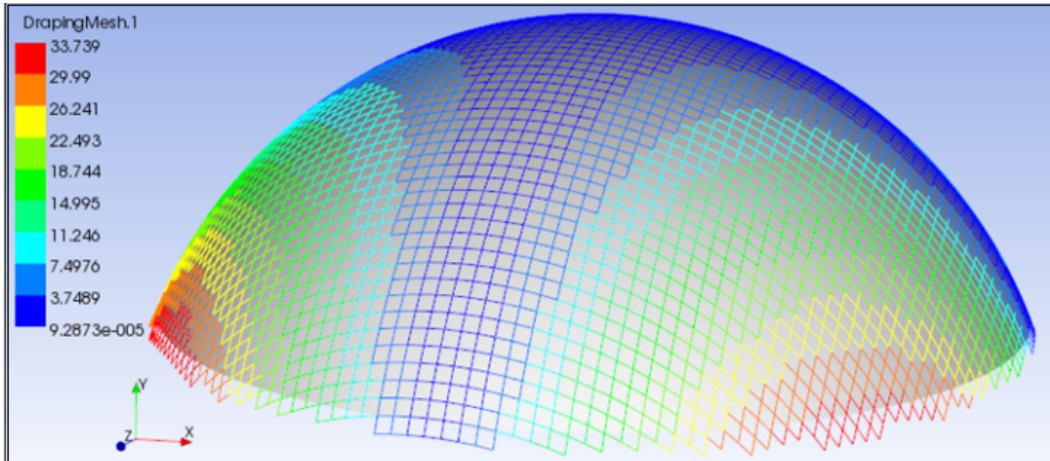
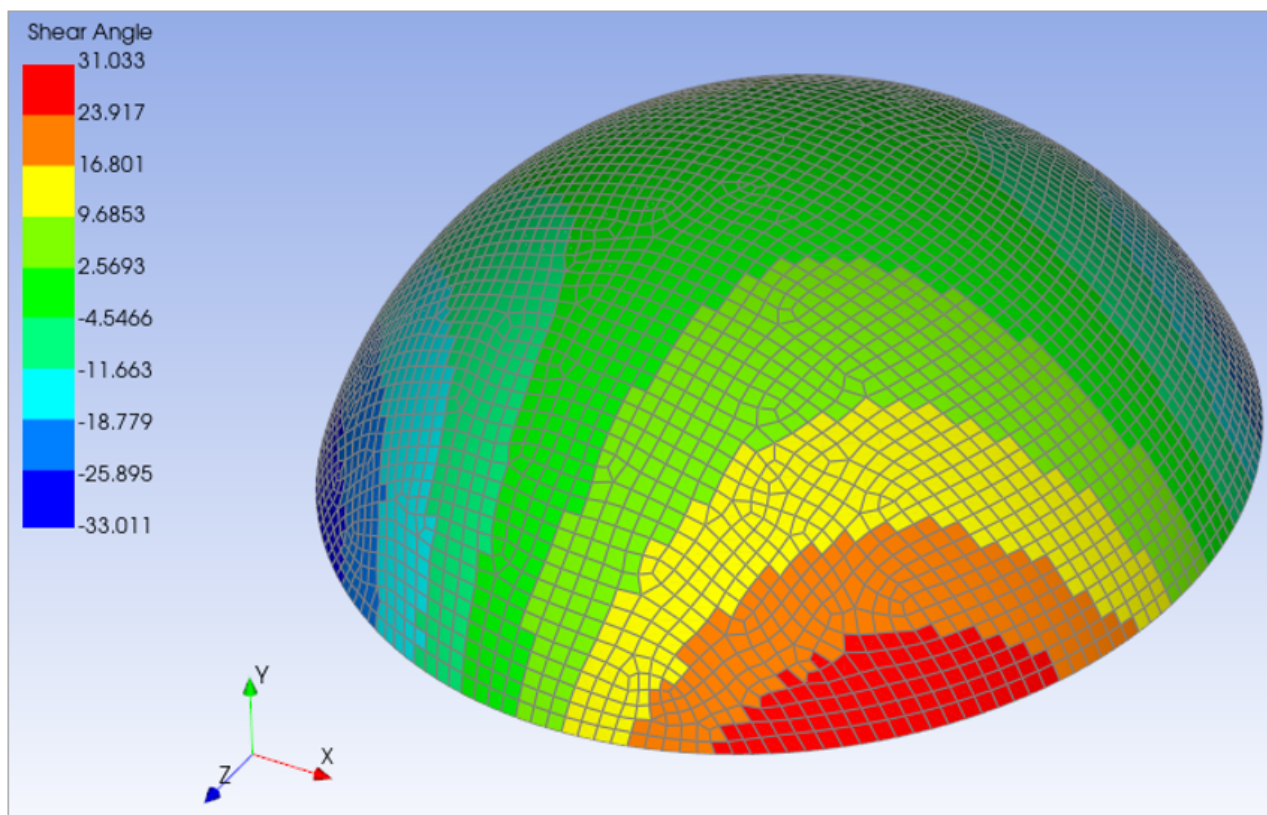

Figure 4.43: Draping Mesh in the ACP Application



You can plot the local ply shear value due to draping using an [Angle Plot](#) (p. 222) with Draped Shear Angle as component.

Figure 4.44: Shear Angle Plot



In addition, you can further investigate the shearing effect due to draping by plotting the draped fiber and transverse directions, as well as the material 1 direction.

Figure 4.45: Draped Fiber Direction (Light Blue), Draped Transverse Direction (Blue) and Material 1 Direction (Red)

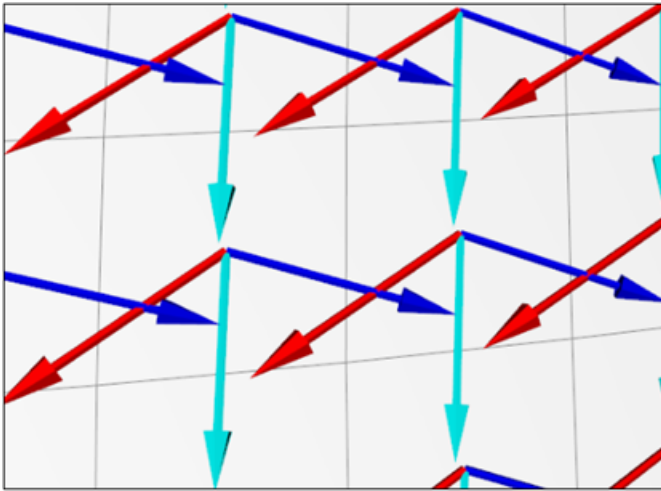

Plot of Shear Dependent Material Properties

The application automatically considers the result of the draping simulation when evaluating the effective material properties in downstream analyses and postprocessing. In the ACP application, you can plot the effective material properties (for example, the Young's modulus) as a function of the Shear Angle using Material Plot.

Figure 4.46: Shear-Dependent Young's Modulus

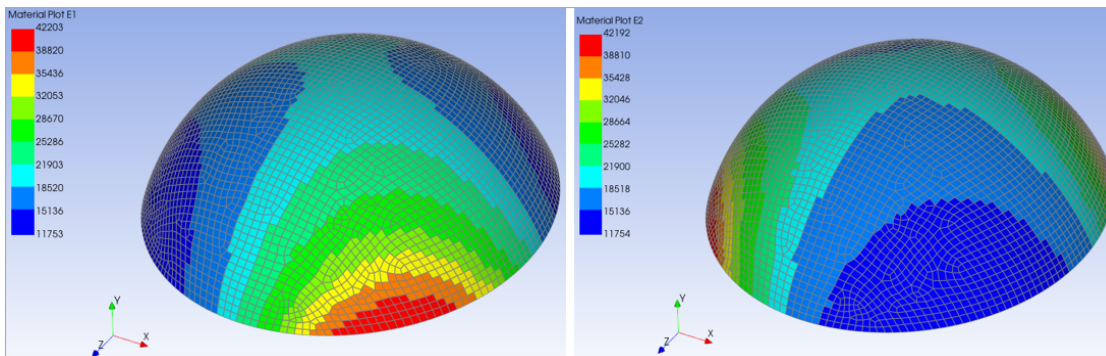

Analysis

The composite model is passed to a structural system to analyze the effect of a uniform pressure load. It is worth comparing the result with the one obtained considering a constant material and no draping: in the latter case the maximum deformation is underestimated by more than 30%.

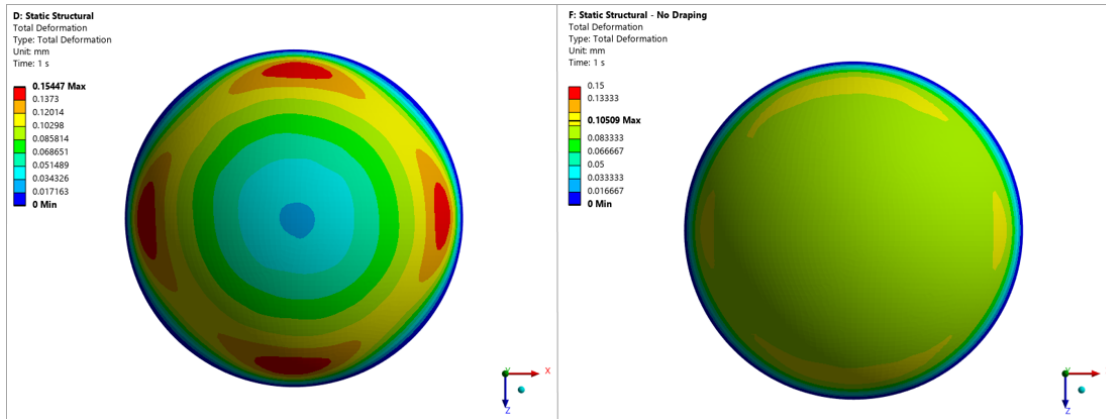
Figure 4.47: Deformation Plot (variable material on left, constant material on right)

4.6. 3D Ply Workflow – Imported Plies

Many different manufacturing processes are available to build composite structures. Traditional processes are mainly used to fabricate thin or moderately thick laminated structures which can be modeled based on a reference surface, also called a mold surface. In ACP (Pre), this is covered by the [Oriented Selection Set](#) (p. 132) and [Modeling Ply](#) (p. 142) features.

New and alternative processes, such as 3D printing and winding, can produce thick and complex structures. In such cases the approach of building the entire laminate on only one reference surface often proves unfeasible or results in an inaccurate model. The [Imported Modeling Ply](#) (p. 160) feature allows you to model laminated structures independent of a reference surface, where the geometrical information (ply extent and so on) is imported from an external source. The lay-up mapping capability, which is part of the [Imported Solid Model](#) (p. 208), is then used to map the Imported Modeling Plies (3D plies) onto a solid mesh. You can employ this workflow in combination with thermal and structural analyses such as linear, transient, or explicit for example.

4.6.1. Inputs

The 3D Ply Workflow requires two additional inputs, compared to the standard workflow. One is a finite element mesh of the solid that represents the 3D composite part, and the other is the 3D representation of the lay-up. The figure below shows how their data can be transferred to ACP (Pre).

In this example, the solid geometry is meshed in the Ansys SpaceClaim application by using block meshing (see A3). The solid mesh is then transferred to ACP Pre-Setup by linking the Ansys Mechanical model (the A4-B5 link). Another option is to mesh the solid geometry in the Mechanical software. You can import meshes from third-party applications (such as HyperMesh) in any supported file format via the External Model system. For more information on supported file formats, see [External Model in the Workbench User's Guide](#).

Note:

- SpaceClaim is no longer included in the unified installer. Ansys recommends using Discovery Modeling to create geometries, or its alternative DesignModeler.

- Named Selections (NS) of the finite element mesh of the solid get transferred to the downstream systems. These Named Selections can be used to define boundary conditions, contacts, and so on, to make the model associative.

Figure 4.48: 3D Ply Workflow (Courtesy of 9T Labs)

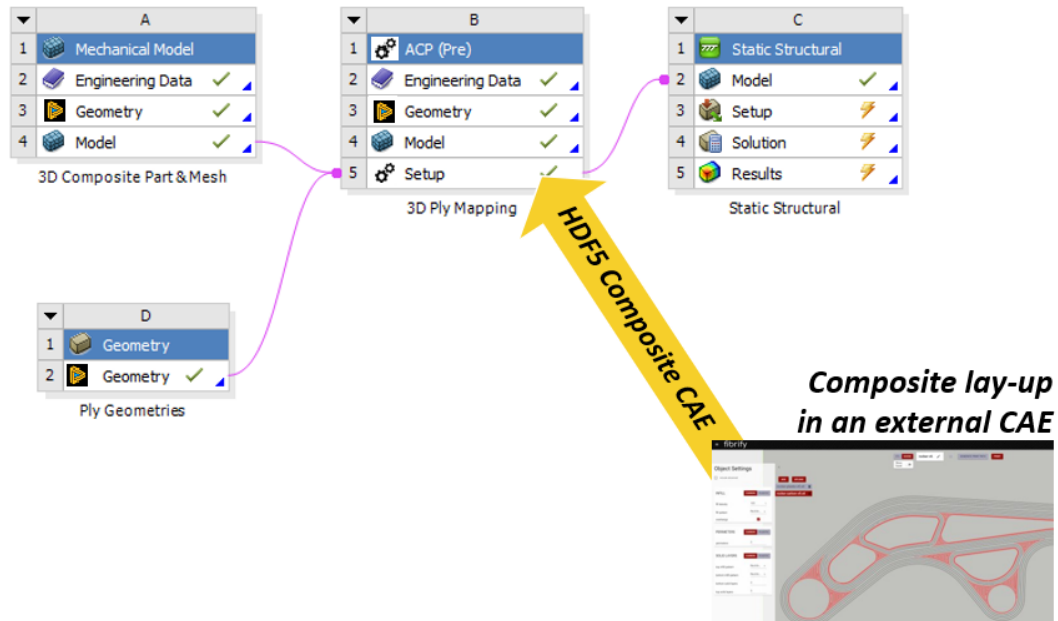

There are two ways to create the 3D ply representations in ACP (Pre). Option A: By geometry. Or option B: By loading an **HDF5 Composite CAE** (p. 245) in ACP (Pre).

Option A: The ply surfaces are represented by CAD faces and are transferred to ACP (Pre) by linking one or more geometrical components with ACP (Pre) (see D2-B5). All the additional information, such as fiber directions and material, can be defined in ACP (Pre) using the standard ACP application features (such as Fabrics, Rosettes, and so on).

Option B: This option allows you to import ply definitions from a third-party application. The HDF5 Composite CAE file includes all the information of a layered composite, so the imported ply objects, their fiber directions, and their thicknesses are created automatically on import. Currently, many CAE applications support the HDF5 Composite CAE. Contact your Ansys Support Team for further information about this format. The figure below shows you how an HDF5 Composite CAE is loaded using the context menu of the ACP application's model.

Figure 4.49: HDF5 Composite CAE Imported as 3D Plies (Imported Modeling Plies)

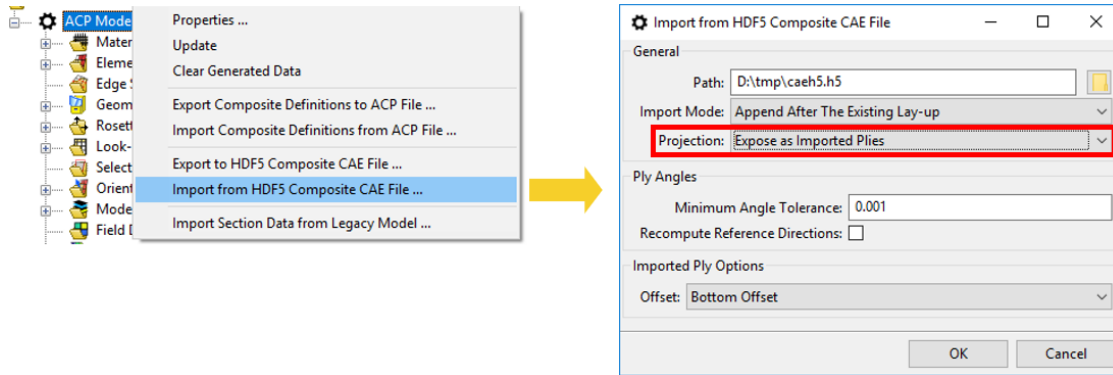

4.6.2. Example of Use - HDF5 Composite CAE

The following example has been provided by 9T Labs (<https://www.9tlabs.com/>) who automates and digitizes composite manufacturing. It shows how a 3D printed composite structure, designed with Fibrify, can be imported into Ansys Workbench/ACP for simulation. This workflow allows you to import a 3D composite lay-up definition and convert it into a solid FE model with minimal effort.

You can download the . You will find the required HDF5 Composite CAE file in the following location:

user_files\200401_Rocker_PA_print_2NEW.hdf5cc

The model is already fully configured, and the description below highlights the most important steps.

Figure 4.50: 3D Printing with Endless Fiber Reinforcement and Final Part (Courtesy of 9T Labs)



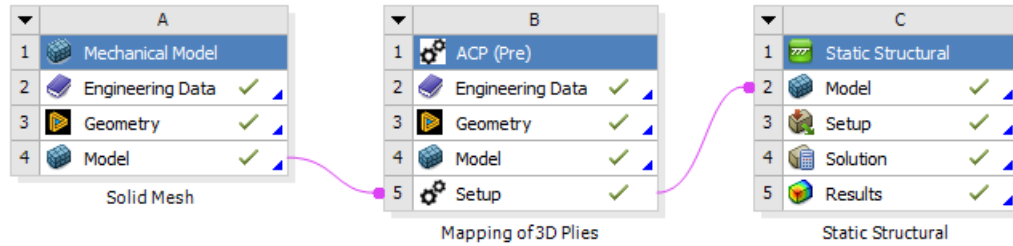

The following figure shows the Workbench **Project Schematic**. The 3D geometry of the printed composite part (shown above) is loaded into system A (Solid Mesh) and meshed in SpaceClaim. Three Named Selections are defined in Model A4 which are used to define the forces and supports later in the analysis system C3. This is important if you want to have an associative model. The material properties (such as stiffness and strengths) are defined in the Engineering Data component (B2) of the ACP Pre system. The solid mesh is transferred to ACP Pre by linking Model A4 with ACP Setup B5 which results in an Imported Solid Model in ACP Pre.

Figure 4.51: Simulation of a 3D Printed Composite (Courtesy of 9T Labs)

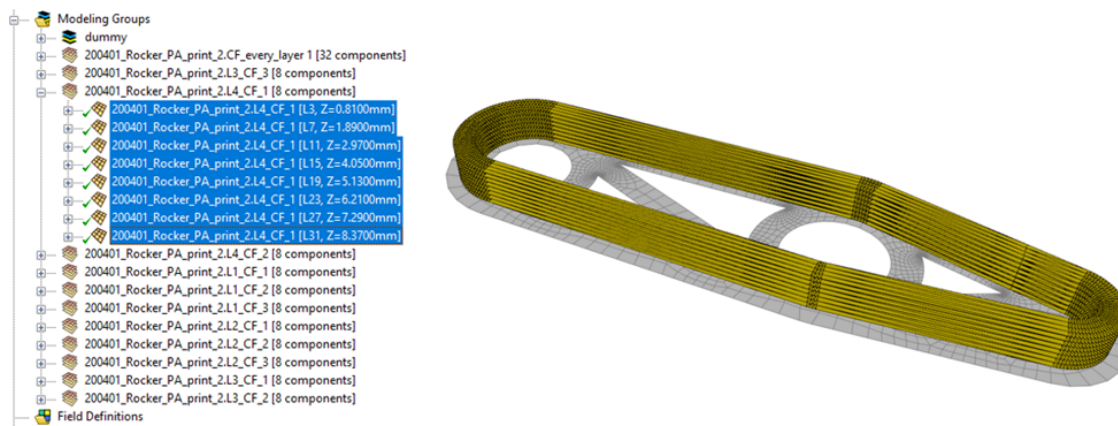

At this point, only a few mouse-clicks are needed in ACP Pre to load the 3D plies and to configure the mapping. You can perform the import using the context menu of the ACP Model as shown above (Figure 4.49: HDF5 Composite CAE Imported as 3D Plies (Imported Modeling Plies) (p. 344)). The imported plies are accessible in the object Tree and are displayed when selected. To see the Fiber Directions and other properties, enable the options in the display's toolbar. Of course, the input data can be modified as well if needed.



The solid mesh on which the plies are mapped is already available (mesh transfer from A4-B5). The mapping algorithm must be switched over to Imported Plies (3D plies) by enabling the **Use Imported Plies** option in the **Imported Solid Model Property Dialog**. By default, all plies are mapped and the result can be verified by selecting the plies of the solid model. The figure below shows a few plies which are visualized on the solid mesh. (Enable the **Show on Solid** option  in the display toolbar and select the plies.)

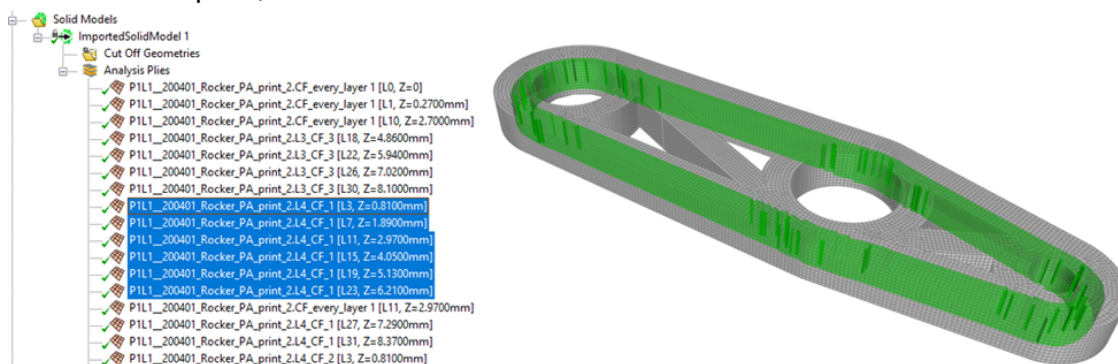

You can now transfer the solid mesh downstream for many different types of analyses, such as a static structural analysis as shown in System C in the workflow above (Figure 4.51: Simulation of a 3D Printed Composite (Courtesy of 9T Labs) (p. 345)). After solving the analysis, you can employ the **Composite Failure Tool** to predict the safety margin of the composite part. As an example, the figure

below shows the maximum Inverse Reserve Factor per element. Of course, you can easily generate ply-wise plots for a more detailed assessment.

Figure 4.52: Distribution of the Inverse Reserve Factors in the Mapped Composite Solid Model

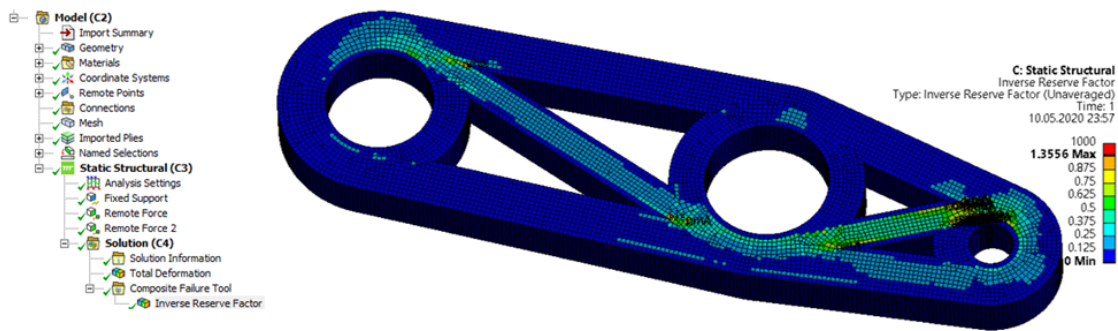

4.7. ACP for Workbench LS-DYNA: Bird Strike

An important part of designing composite structures is fulfilling performance and reliability targets under operational loads. Most structures are subject to quasi-static or transient phenomena where implicit time integration is sufficient. However, when engineers want to understand the structural behavior under short duration events, explicit time integration methods are necessary. Common scenarios include assessing passenger safety in a vehicle crash event, predicting the damage state of consumer goods in a drop scenario, or predicting the effects of a bird strike on an aircraft and the impact on its ability to land safely.

Composite models may exhibit complex lay-up patterns when they involve multiple layers, local reinforcements, and different materials and orientations. While defining lay-ups in LS-PrePost is tedious and prone to errors, [ACP provides all the functionality \(p. 1\)](#) needed to generate parametric composite models efficiently and accurately. You can use these composite models for both implicit analyses in Ansys Mechanical APDL and explicit analyses in [LS-DYNA](#).

The example that follows shows how to set up a composite model for a bird strike analysis within Ansys Composite PrepPost for an explicit simulation within Ansys Workbench LS-DYNA. In principle, the workflow corresponds to the implicit structural [analysis of a composite shell model \(p. 307\)](#). The modeling steps that have specific application to the Workbench LS-DYNA analysis are given special attention. For example:

 The Workbench project file can be downloaded here:

Tip:

For general considerations and limitations regarding the ACP-to-Workbench LS-DYNA workflow, see [ACP-LS-DYNA \(p. 45\)](#).

4.7.1. Workbench Workflow

4.7.2. Engineering Data – Material Model Definition

4.7.3. SpaceClaim – Geometry

4.7.4. Mechanical Model Setup

4.7.5. ACP - Material Assignment and Lay-Up

4.7.6. Setting Up the LS-DYNA Analysis System

4.7.7. Post-Processing in Workbench LS-DYNA:

4.7.1. Workbench Workflow

The ACP to WB-LSDYNA workflow is similar to a standard implicit [Analysis of a Composite Shell Model](#) (p. 307) using ACP and Ansys Mechanical: The required analysis systems are placed on the Workbench **Project Schematic** and connected (p. 313). In the case of a composite analysis with LS-DYNA, you drag-and-drop an [LS-DYNA analysis system](#) onto the Workbench schematic.

Figure 4.53: The Drag-and-Drop Workflow Showing the Transfer of ACP Composite Models to a Workbench LS-DYNA Analysis System

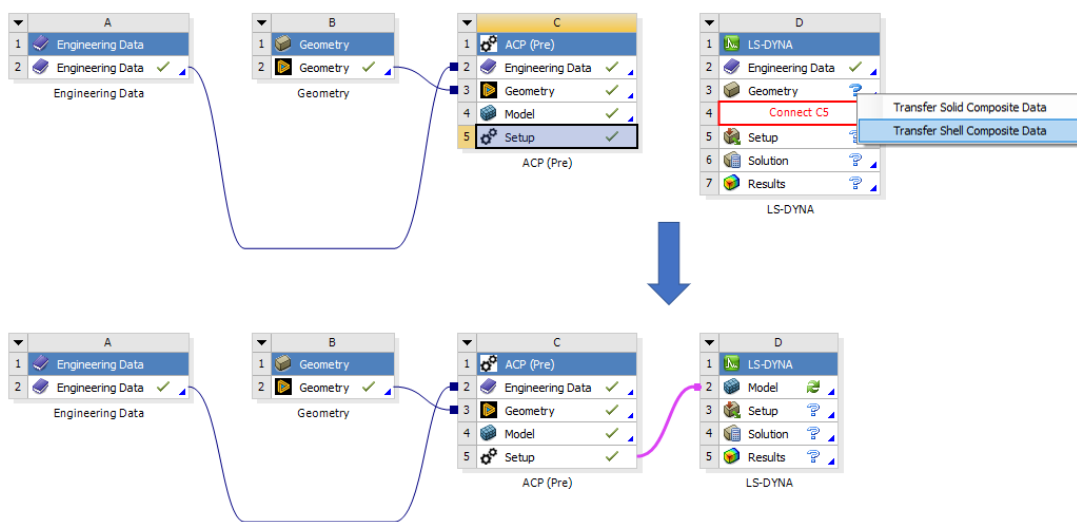

4.7.2. Engineering Data – Material Model Definition

The material data required for the LS-DYNA model is defined in the [Engineering Data](#). There are two ways the LS-DYNA material cards are generated from the workflow:

1. **Ansys standard material property definitions are automatically converted into the equivalent LS-DYNA material model.**

Once the ACP model is transferred to the **LS-DYNA** system, you can choose which LS-DYNA composite material model is used by selecting **Composite Damage Model** in **Composite Controls**, located under **Details of Analysis Settings**. This converts a basic set of parameters. This is a global control which defines the entire composite model by one of the two available material models:

- ENHANCED_COMPOSITE_DAMAGE / *MAT054
- LAMINATED_COMPOSITE_FABRIC / *MAT058

Figure 4.54: Setting up an Automatic Conversion of LS-DYNA Material Models

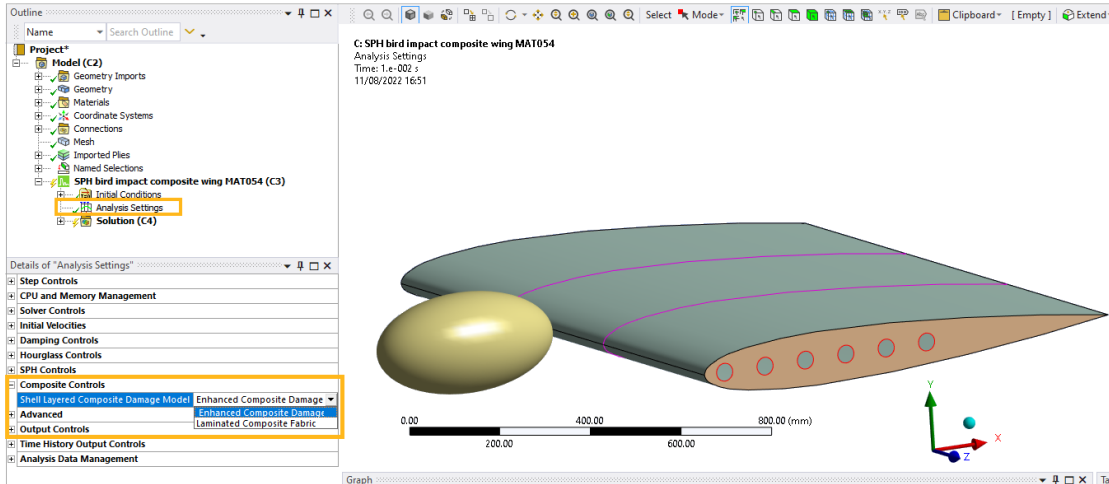

2. You directly define the LS-DYNA material model.

Composite structures are often made of different materials, each exhibiting its own material behaviors. This might require using multiple material models. **Engineering Data** simplifies the task by giving you access to several LS-DYNA material cards, allowing complete control over stiffness and damage parameters as well as degradation properties.

The model used in this example contains a unidirectional and a woven material. Each is represented by a specific LS-DYNA material model:

- UD - *MAT_ENHANCED_COMPOSITE_DAMAGE/*MAT054
- Woven - *MAT_LAMINATED_COMPOSITE_FABRIC/*MAT058

Figure 4.55: Material Definition for LS-DYNA in Engineering Data

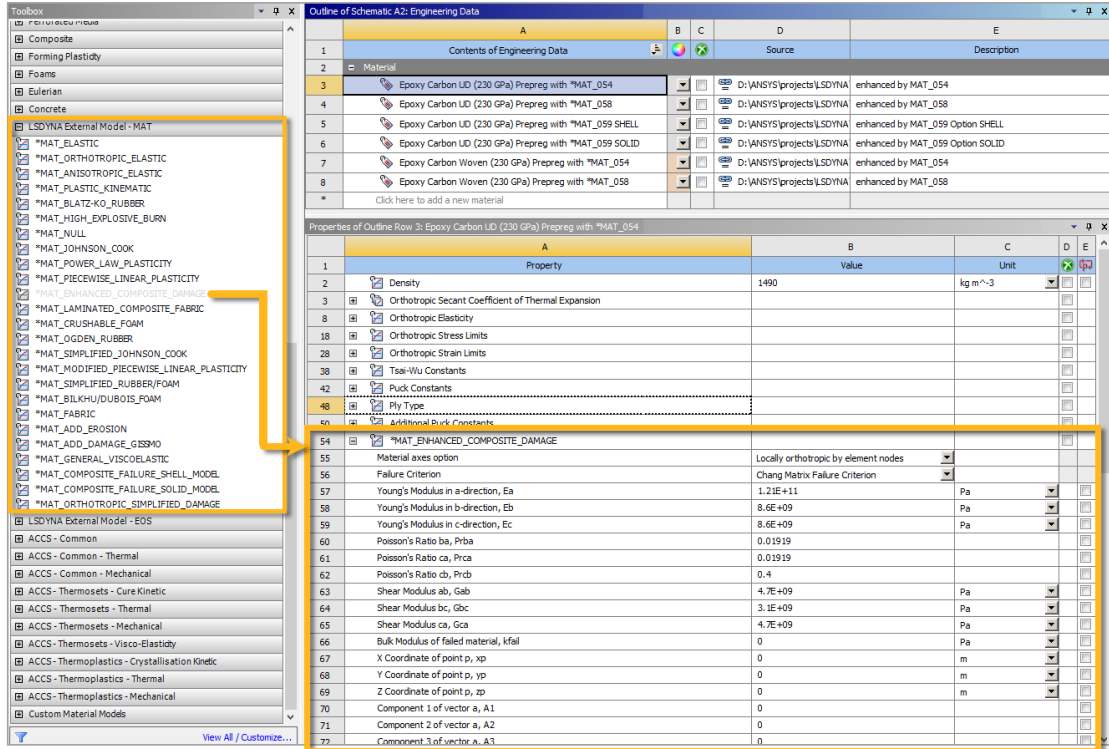

4.7.3. SpaceClaim – Geometry

The geometry is generated in SpaceClaim. It includes a solid geometry which represents the bird (A in the figure below) and the surface geometry of the composite wing structure (B). The distance (C) between the bird and the wing is set to minimize the time between the beginning of the simulation and the impact event.

Note:

SpaceClaim is no longer included in the unified installer. Ansys recommends using Discovery Modeling to create geometries, or its alternative DesignModeler.

Figure 4.56: Geometry Preparation in SpaceClaim

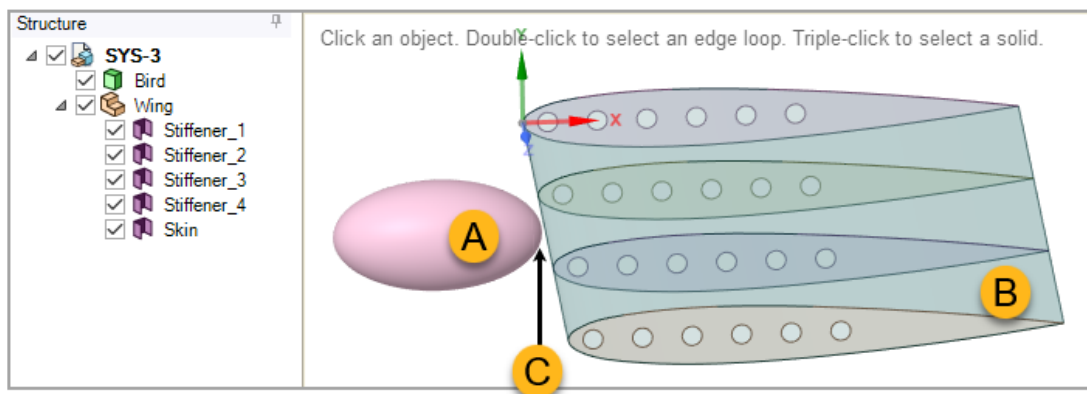

4.7.4. Mechanical Model Setup

The geometry is then transferred to the Mechanical model where the following entities must be defined:

- **Geometry Properties**
 - **Reference Frame:** The **Reference Frame** of the bird is set to **Particle** which allows the mesh generation method with SPH particles. In contrast, the **Reference Frame** of the wing geometry is set to **Lagrangian** by default.
 - **Material:** For the bird geometry, **Water2** is assigned, an equation-of-state material model for water. For the bodies of the wing geometry, the default material assignment is retained but will be overwritten by the composite definition in ACP-Pre.

Figure 4.57: Mechanical Model - Assigning Part Properties to the Bird Body

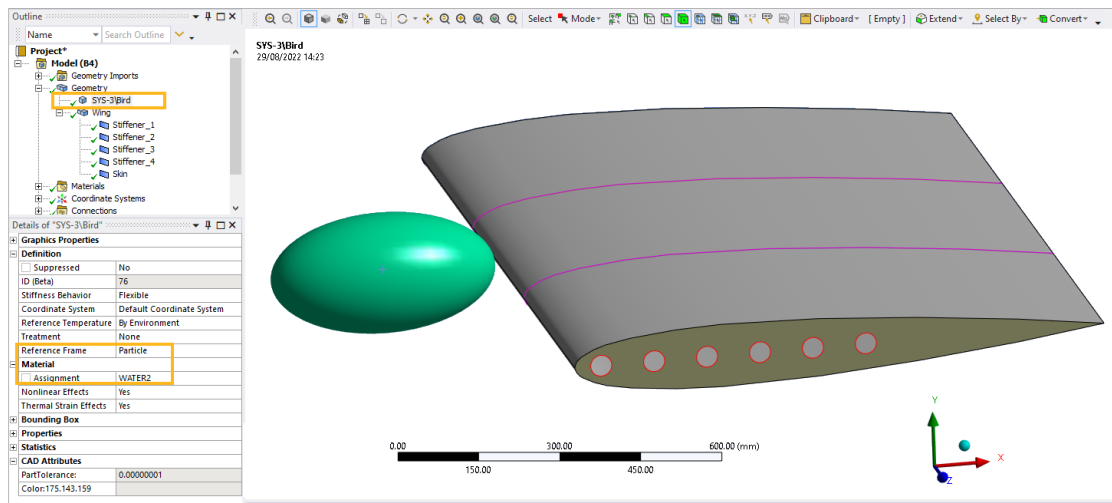

- **Mesh**

The mesh **Physics Preference** is set to **Explicit**. A **Particle Method** is used for the mesh generation of the bird. A multizone meshing approach is chosen for the wing geometry which allows the generation of a suitable structural mesh-type for explicit analysis.

- **Named Selections**

Named Selections for some part domains are defined. ACP-Pre uses the Named Selections to set up various functional domains for assigning composite plies.

4.7.5. ACP - Material Assignment and Lay-Up

Material Assignment

Because each LS-DYNA material model in **Engineering Data** has its own definition, you can assign specific materials to each individual ply. If a material without an LS-DYNA definition is used, it is automatically converted to the preset LS-DYNA material card. The workflow for [defining Fabrics, Stackups, and Sub-Laminates in ACP \(p. 74\)](#) does not differ from standard composite model generation.

The model in this example uses two different Fabrics, one for the woven and another for the unidirectional material. You must define Fabric **Thickness** in the **Fabric Properties** dialog. Additional but optional controls (p. 84) are available for draping computation and solid model material handling for degenerated elements.

Figure 4.58: Defining Materials in ACP

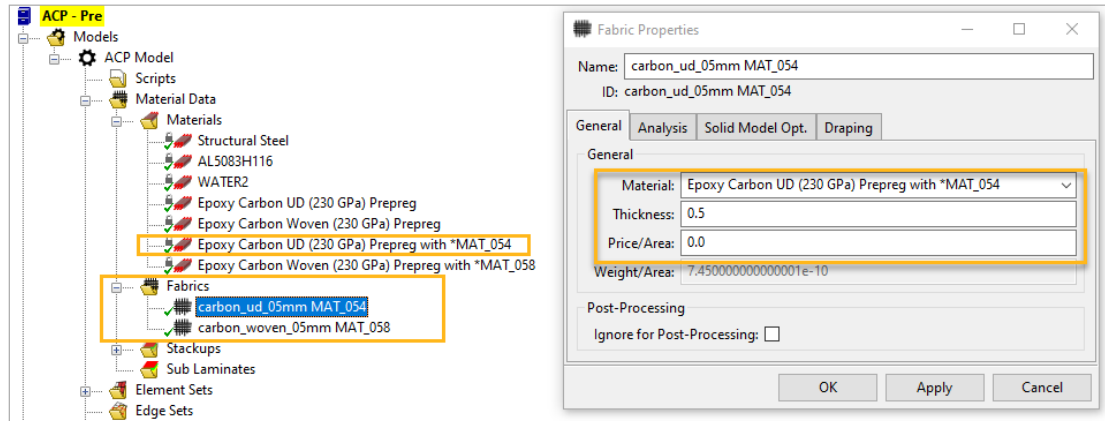

Lay-Up

The composite lay-up contains the two different materials previously defined. The stiffeners and the base lay-up of the skins are made from the unidirectional material. Additional woven materials are applied to the trailing edge of the wing as a local reinforcement. The ply stacking direction of the skin points inward as defined through the underlying Oriented Selection Set of the modeling plies.

Figure 4.59: Composite Lay-Up Modeling in ACP

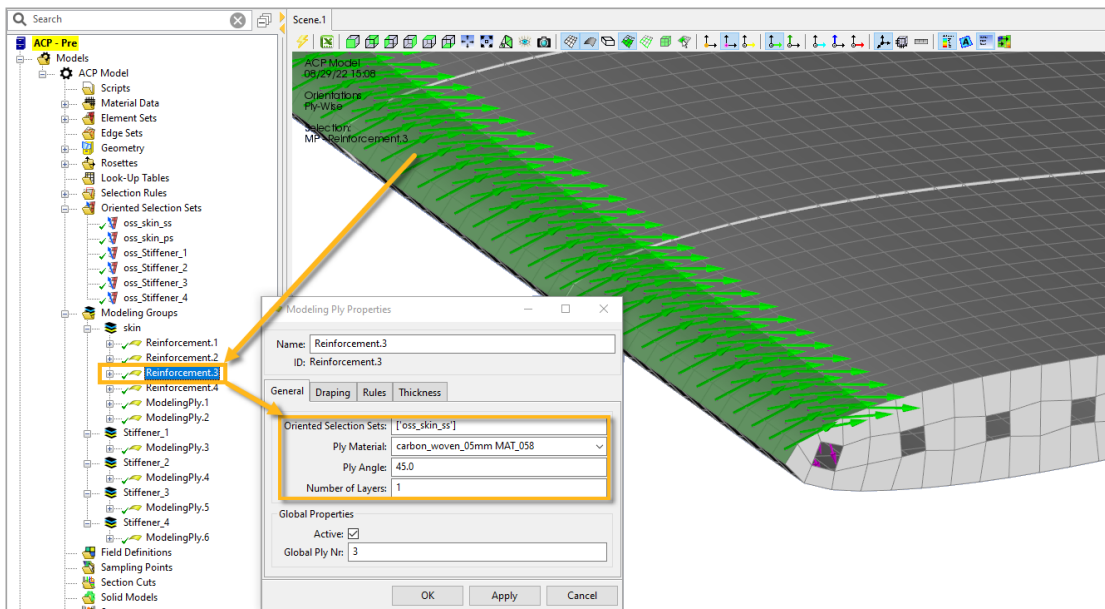

4.7.6. Setting Up the LS-DYNA Analysis System

The composite lay-up from ACP is transferred to LS-DYNA as a shell model where the wing as well as the bird model is now present with their required model configuration. A **Body Interaction** object

is added by default and includes all bodies present in the model. A **Fixed Support** is applied to one of the Stiffeners. A Velocity of 125 m/sec is applied to the bird body as an **Initial Condition**.

Figure 4.60: : Setting Up the Analysis

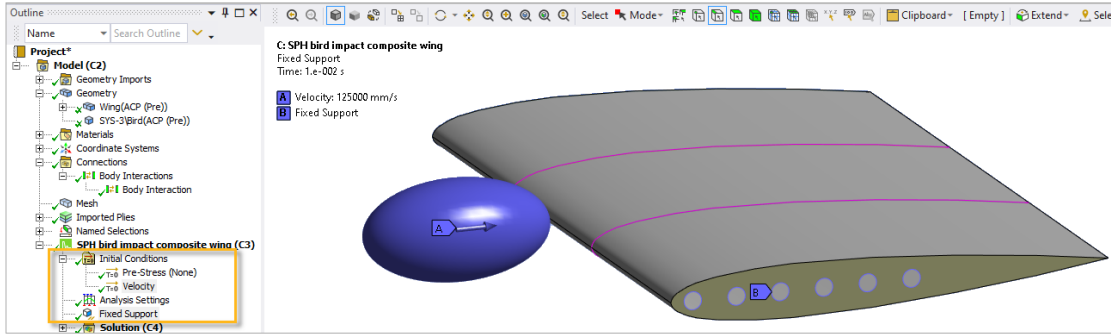

The Details View of **Analysis Settings** provides additional controls for the solver run and output entities:

- **End Time** is set to 0.01 seconds.
- Under **Output Controls**, **History Variables** is set to **Yes**.
- Under **Time History Output Controls**, different output entities are specified (for example: **Element Data** and **Nodal Data**).
- Other control entities are available such as for **SPH Controls**, **Processing Type**, **CPU and Memory Management**, and **Solver Precision**.

4.7.7. Post-Processing in Workbench LS-DYNA:

In Ansys Mechanical, you can review very basic result entities such as deformations, strains, and stresses.

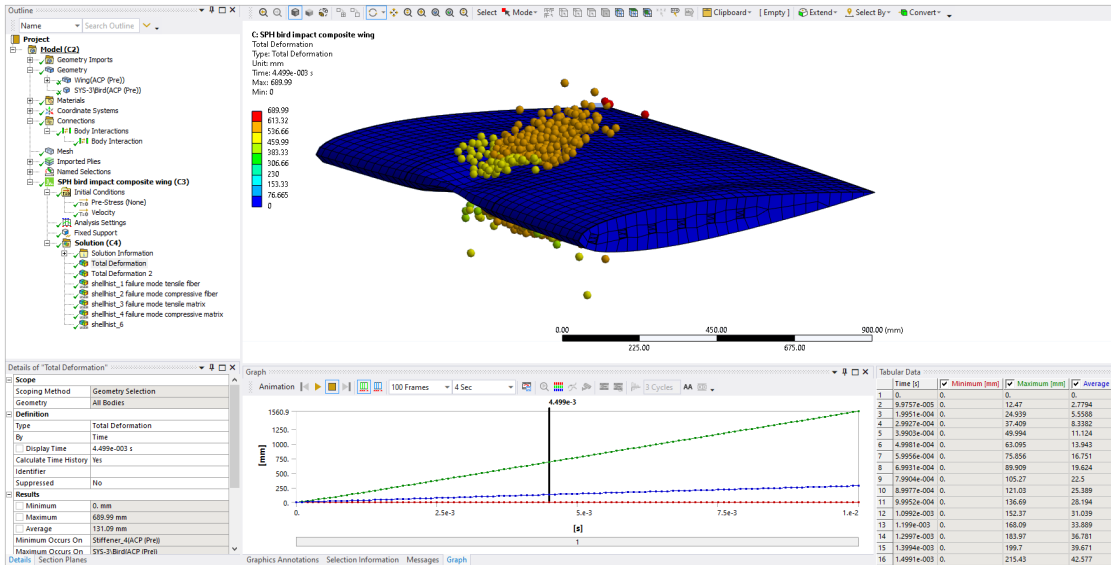

You can evaluate the history variable output through a user-defined result. Be aware that the history variables have a different meaning for each material model (see [History Variable Output in the LS-DYNA User's Guide](#)).

For advanced result analyses, you can open the result files and model input files in LS-PrePost. Right-click the **Solution** object and select **Open Solver Files Directory** in the context menu.

Figure 4.61: Accessing Input Files and Results Files

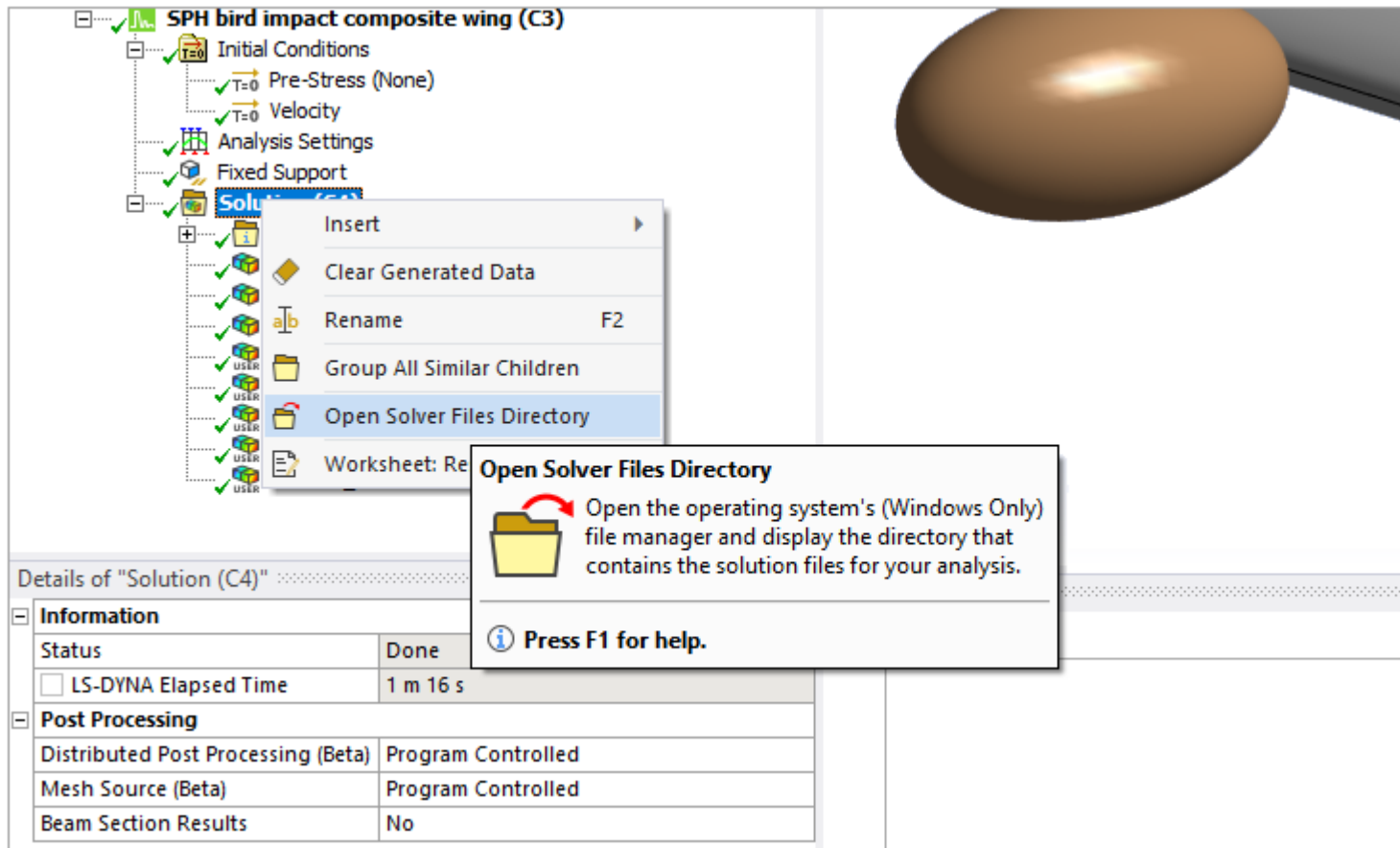

Alternatively, you can use the free ACT extension **LST_PrePost** (available in the [Ansys Store](#)) to open the LS-DYNA solver and results files and seamlessly perform further pre- and post-processing. Additional pre- and post-processing capabilities in Workbench LS-DYNA will be added in future releases.

4.8. Workflow with Equivalent Beam Models

The two examples in this section demonstrate how to set up an equivalent beam model of a layered composite shell structure. ACP (Pre) is used to compute the equivalent sectional properties from the shell-based 3D composite models. This workflow is typically used for slender structures such as wind turbine blades or helicopter rotor blades to efficiently evaluate their dynamic behavior. In each example, the results of the beam model are compared with the 3D model. In both cases, the results are very similar, which shows the accuracy of the workflow.

4.8.1. Constant Composite Cross Section with a Straight Beam

4.8.2. Generic Composite Wind Blade

4.8.3. Conclusion

The first example is a composites box with a constant cross section and laminate. The second example is a generic wind turbine blade where the cross section and the laminate vary along the longitudinal axis. Both have the same project schematic in the Workbench application as shown in [Figure 4.62: Workflow of a Model Analysis with an Equivalent Beam Model \(p. 354\)](#). The top systems are used to configure the 3D model, which steps include:

- Importing the shell geometry and meshing it in the Mechanical application (**A4**)
- Defining the layup in **ACP (Pre) (A5)** and computing the equivalent beam properties
- Preparing the APDL input for the beam model in the **Modal: Beam model (C)** system
- Running the same analysis with the shell or solid model in the **Modal Solid (B)** system to compare the results with the equivalent beam model

The analysis with the equivalent beam model is configured in the **Modal: Beam model (C)** system. It contains the beam elements and the computed equivalent section properties from **ACP (Pre) (A5)** which are passed to the solver by an APDL Command snippet.

Important:

Use the same unit system in **ACP (Pre) (A5)** and **Modal: Beam model (C)** to ensure that the computed beam properties have proper units.

Figure 4.62: Workflow of a Model Analysis with an Equivalent Beam Model

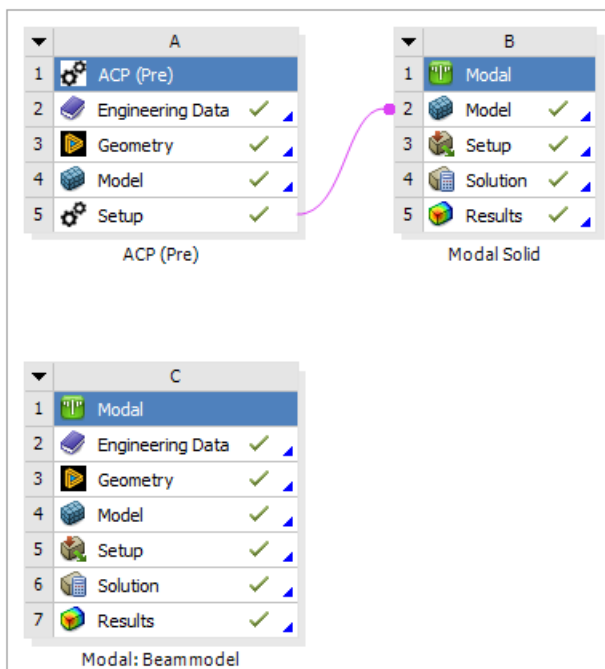

4.8.1. Constant Composite Cross Section with a Straight Beam

The base to compute the equivalent beam properties is a generic straight box-like composite structure with constant cross section and constant composite layup along the length. A consequent equivalent

beam model is built, and its frequencies are compared against the 3D model frequencies (SOLID185 elements).

The fully configured Workbench project is contained in a compressed file and can be downloaded . This configured project requires Release 2024 R2 or more recent versions.

The section is shown in the following figure with the coarse mesh used to access the methodology. The material properties are listed in the table.

Figure 4.63: Cross Section and Layup of the Box

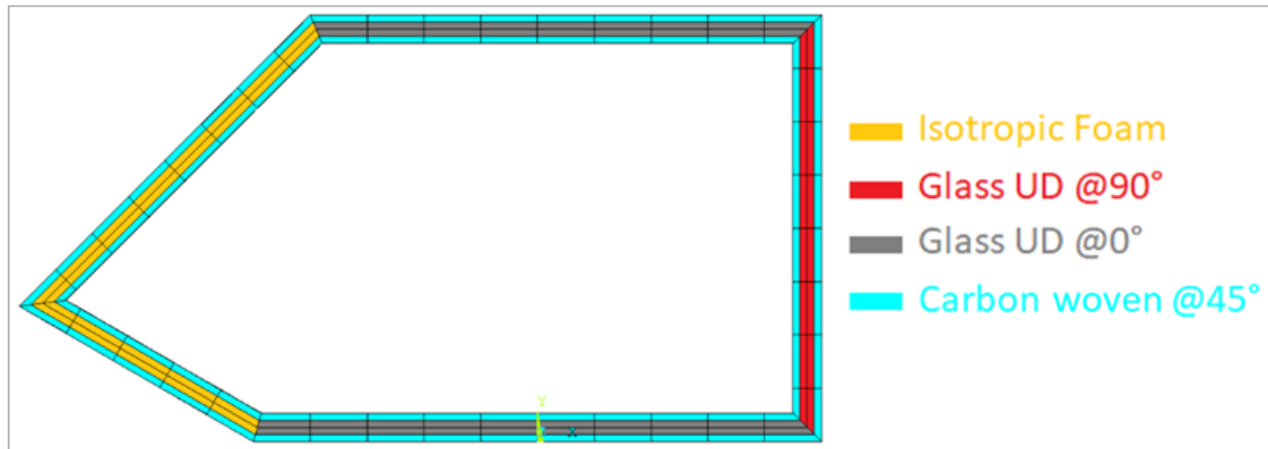

Table 4.1: Material Properties

	Foam	Glass UD	Carbon Woven
Ex [Mpa]	70	45000	61340
Ey [Mpa]	70	10000	61340
Ez [Mpa]	70	10000	6900
Gxy [Mpa]	26.92	5000	3300
Gxz [Mpa]	26.92	5000	2700
Gyz [Mpa]	26.92	3846.15	2700
ν_{xy}	0.3	0.3	0.04
ν_{xz}	0.3	0.3	0.3
ν_{yz}	0.3	0.4	0.3
Density [t/mm ³]	6E-11	2.0E-09	1.42E-09

For this example, the reference point considered for the cross section properties is the **Origin**. The following shows the calculation result.

Figure 4.64: Computation Result of the Equivalent Beam Properties

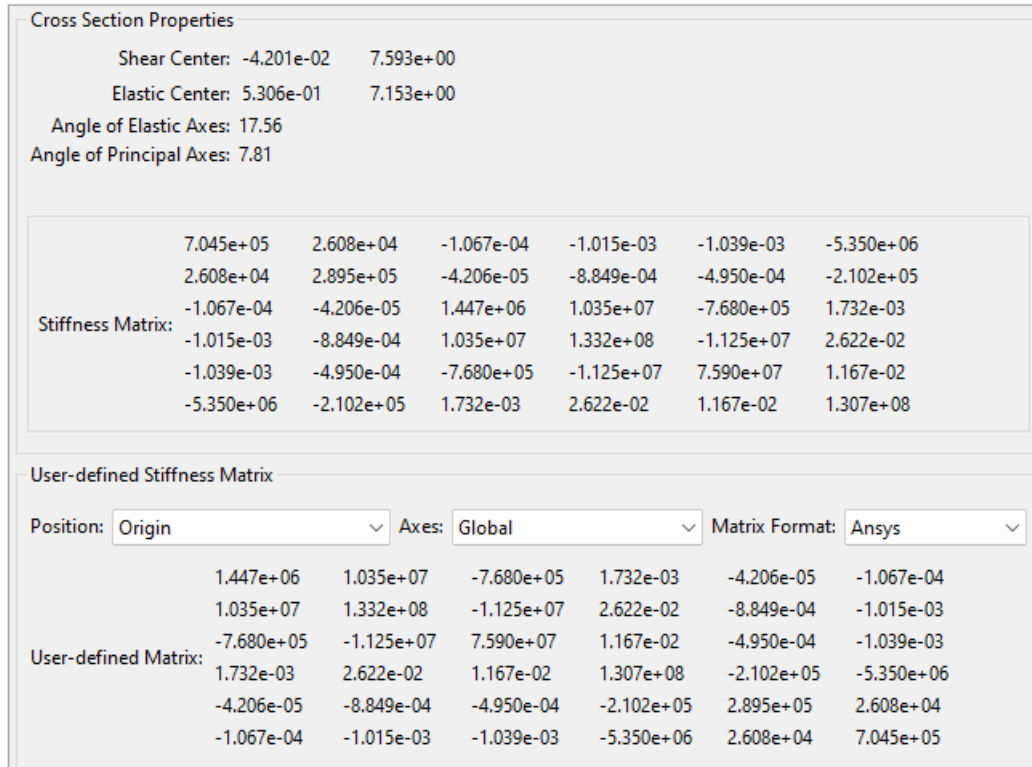
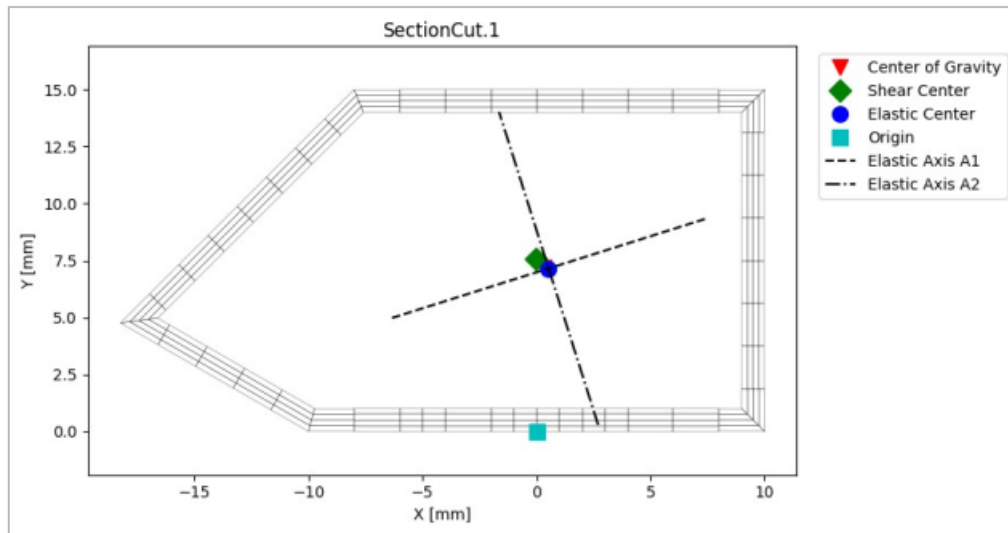

Figure 4.65: Mesh of the Cross Section and its Principal Properties



A simple straight beam of the desired length is created in SpaceClaim and meshed in the Mechanical application. The equivalent beam model is built in the Mechanical system **Modal: Beam model (C)** by adding an APDL snippet under the **Geometry** object in the Tree View. The results from the Section Cut computation in ACP are directly pasted here as shown below. Alternatively, a Python script could be inserted in ACP which automatically generates the APDL inputs (APDL file). This file can then be

loaded by the Command Snippet object in the Mechanical. The Python script option enables further automation of the workflow.

Note:

SpaceClaim is no longer included in the unified installer. Ansys recommends using Discovery Modeling to create geometries, or its alternative DesignModeler.

Figure 4.66: APDL Snippet to Apply the Beam Properties

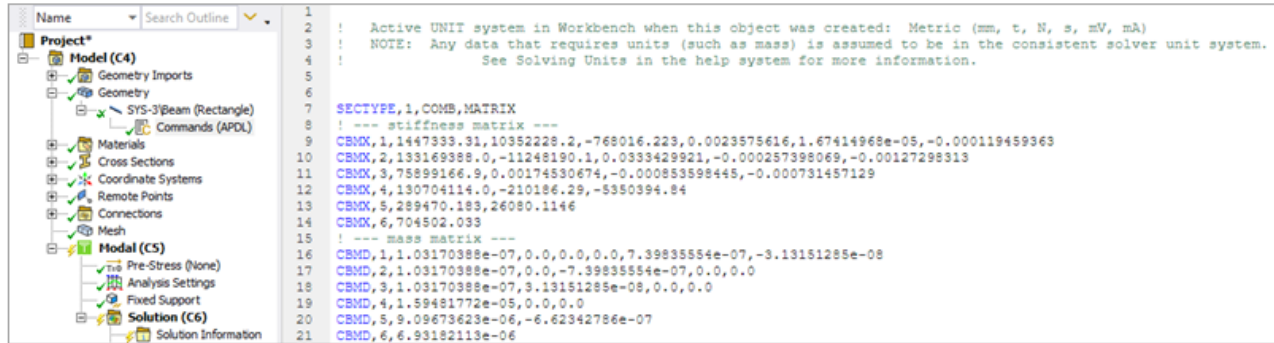

The beam is fixed on one end and the first six frequencies are calculated. The table below compares the results of the 3D solid model and equivalent beam model.

Table 4.2: Comparison of the 3D Solid Model and Equivalent Beam Model Results

Frequency	3D Model	Equivalent Beam	Diff. %
1	82.574	82.152	-0.511
2	95.958	95.484	-0.494
3	509.19	504.95	-0.833
4	592.73	589.07	-0.617
5	1384.1	1372.7	-0.824
6	1619.6	1610.5	-0.562

The following figure shows a comparison of the mode shapes for the first and fifth frequencies.

Figure 4.67: Comparison of Mode Shapes for the First and Fifth Frequencies

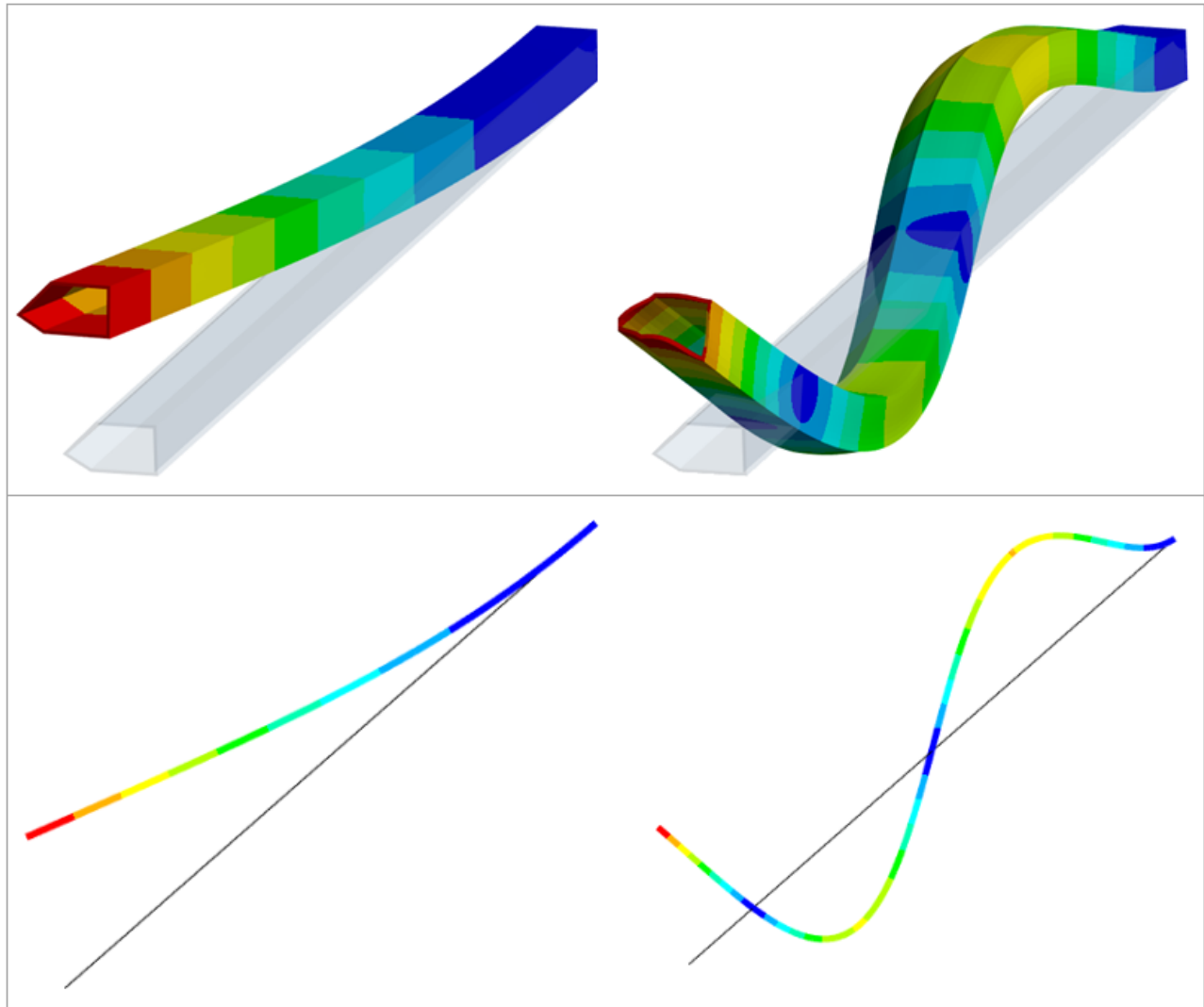

You may compare the data of the inertia properties for the 3D solid model and equivalent beam model using the reports below.

3D Solid Model

```

***** PRECISE MASS SUMMARY *****

TOTAL RIGID BODY MASS MATRIX ABOUT ORIGIN
  Translational mass      | Coupled translational/rotational mass
  0.41268E-04  0.0000      | 0.0000      0.82536E-02 -0.29593E-03
  0.0000      0.41268E-04  | -0.82536E-02 0.0000      0.12526E-04
  0.0000      0.0000      | 0.29593E-03 -0.12526E-04 0.0000
-----|-----
                                         Rotational mass (inertia)
                                         |
                                         | 2.2046      -0.26494E-03 -0.25052E-02
                                         | -0.26494E-03 2.2037      -0.59187E-01
                                         | -0.25052E-02 -0.59187E-01 0.63793E-02

TOTAL MASS = 0.41268E-04
The mass principal axes coincide with the global Cartesian axes

CENTER OF MASS (X,Y,Z)= 0.30353      7.1710      200.00

TOTAL INERTIA ABOUT CENTER OF MASS
  0.55174      -0.17511E-03 0.19357E-09
 -0.17511E-03 0.55299      0.40623E-10
  0.19357E-09 0.40623E-10 0.42533E-02
The inertia principal axes coincide with the global Cartesian axes

```

Equivalent Beam Model

```

***** PRECISE MASS SUMMARY *****

TOTAL RIGID BODY MASS MATRIX ABOUT ORIGIN
  Translational mass      | Coupled translational/rotational mass
  0.41268E-04 -0.14092E-35 0.0000      | 0.28179E-33 0.82536E-02 -0.29593E-03
 -0.14092E-35 0.41268E-04 0.0000      | -0.82536E-02 -0.28189E-33 0.12526E-04
  0.0000      0.0000      0.41268E-04 | 0.29593E-03 -0.12526E-04 0.0000
-----|-----
                                         Rotational mass (inertia)
                                         |
                                         | 2.2046      -0.26494E-03 -0.25052E-02
                                         | -0.26494E-03 2.2037      -0.59187E-01
                                         | -0.25052E-02 -0.59187E-01 0.63793E-02

TOTAL MASS = 0.41268E-04
The mass principal axes coincide with the global Cartesian axes

CENTER OF MASS (X,Y,Z)= 0.30353      7.1710      200.00

TOTAL INERTIA ABOUT CENTER OF MASS
  0.55176      -0.17511E-03 0.21358E-17
 -0.17511E-03 0.55301      0.39975E-16
  0.21358E-17 0.39975E-16 0.42533E-02
The inertia principal axes coincide with the global Cartesian axes

```

4.8.2. Generic Composite Wind Blade

This example is based on a generic composite wind blade with variable cross section, realistic sub-components, materials, and thickness distribution. It is used as the base to compute the equivalent beam properties. A modal analysis is run on the equivalent beam model and its frequencies are compared against the 3D Shell model frequencies ([SHELL181](#) elements).

 The fully configured Workbench project is contained in a compressed file and can be downloaded . This configured project requires Release 2025 R1 or more recent versions.

The blade has a circular root section that transitions to aerodynamics airfoil. Its structure mimics a typical wind blade with longitudinal UD spar caps, a shear web, trailing edge UD reinforcement, +/- 45 external skins, and core material in the panels.

Figure 4.68: Geometry of the Generic Wind Turbine Blade

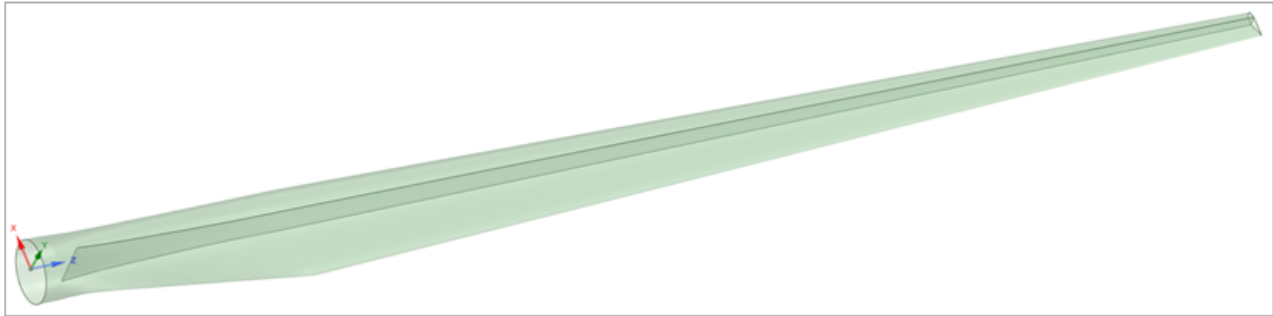

The material properties are listed in the table below.

Table 4.3: Material Properties

	Foam	Glass UD
Ex [Mpa]	70	45000
Ey [Mpa]	70	10000
Ez [Mpa]	70	10000
Gxy [Mpa]	26.92	5000
Gxz [Mpa]	26.92	5000
Gyz [Mpa]	26.92	5000
ν_{xy}	0.3	0.3
ν_{xz}	0.3	0.3
ν_{yz}	0.3	0.4
Density [t/mm ³]	6E-11	2.0E-09

The blade is 50.6 m long and, due to the variable cross section and design, the beam model has 101 elements. This means that the sectional properties have to be calculated at 101 locations. Ideally, the section cuts are in the middle of each section cut.

There are two Python scripts in the ACP model. The first is to generate the section cuts at the right locations (middle of each beam element). And the second script is to write the results as sectional properties to an APDL input file. The script is based on the example [Export Section Cut]. The generated output must be manually copied into the APDL Command snippet or refresh the Command snippet to load it directly from the generated APDL input file.

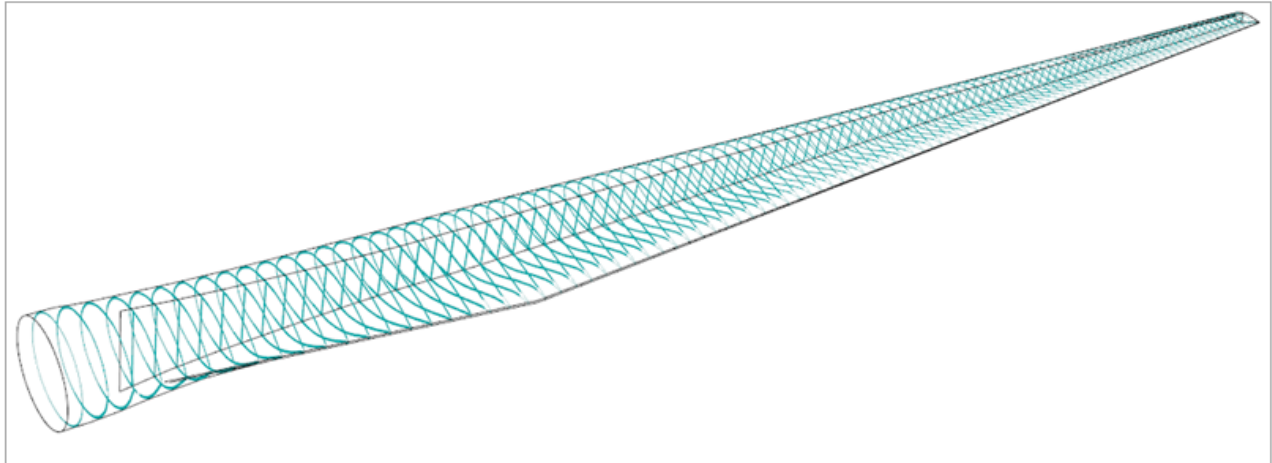
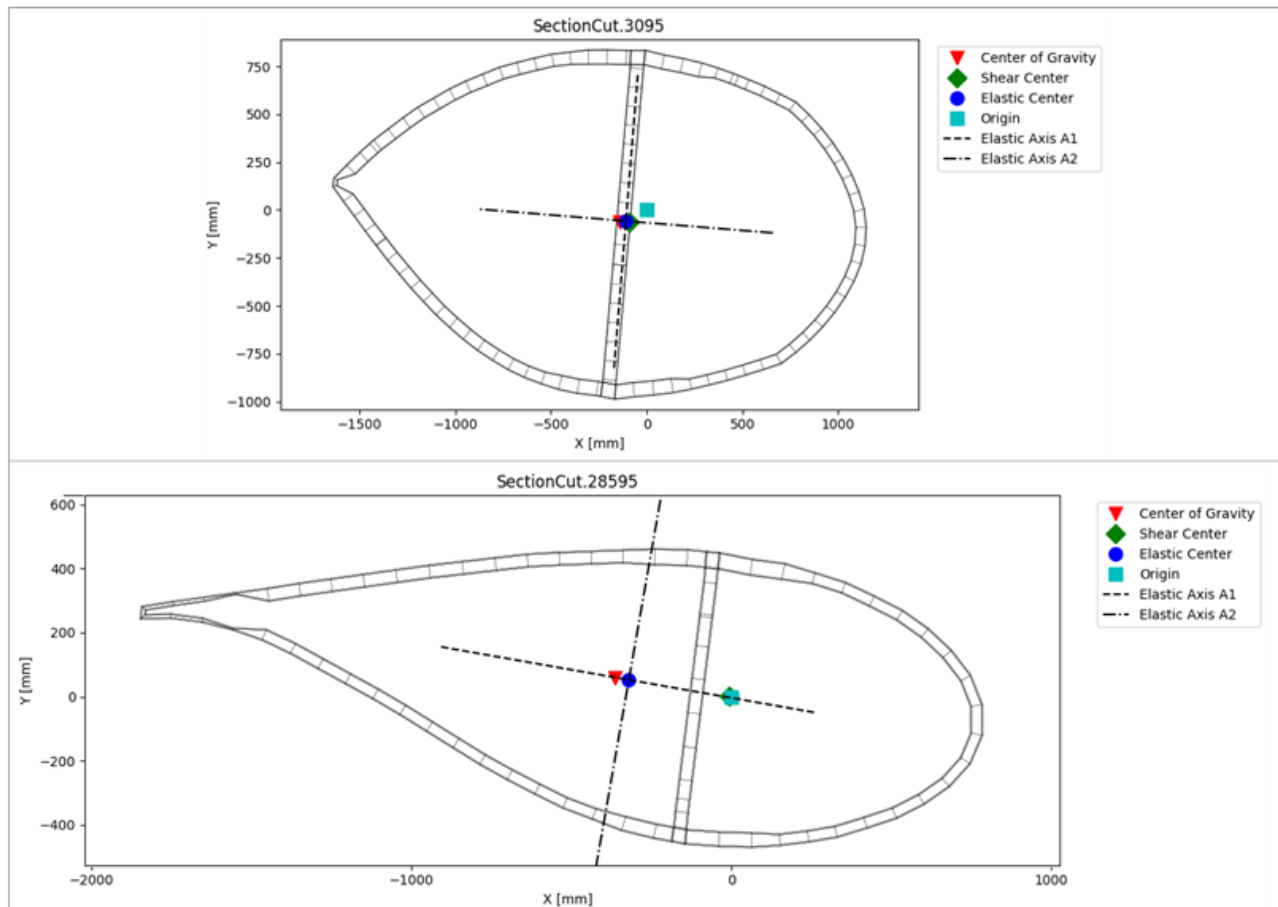
Figure 4.69: Wind Turbine Blade with the 101 Cross Sections**Figure 4.70: Two Meshes of Different Cross Sections and the Corresponding Shear, Elastic, and Center of Gravity**

For this example, the reference point considered for the cross section properties is the **Origin**. The Mesh (nodes and elements) for the beam model is created conveniently in Mechanical APDL to place the nodes at the desired location along the span of the blade. Then, this model is imported into the Workbench application via an external model (.cdb) and can be opened in the Mechanical application,

where using an APDL snippet, each element property is reassigned according to the calculated values for each cross section (these values were saved through the ACP Python script into a .cdb file)

Figure 4.71: APDL Snippet with the Generated Output from ACP

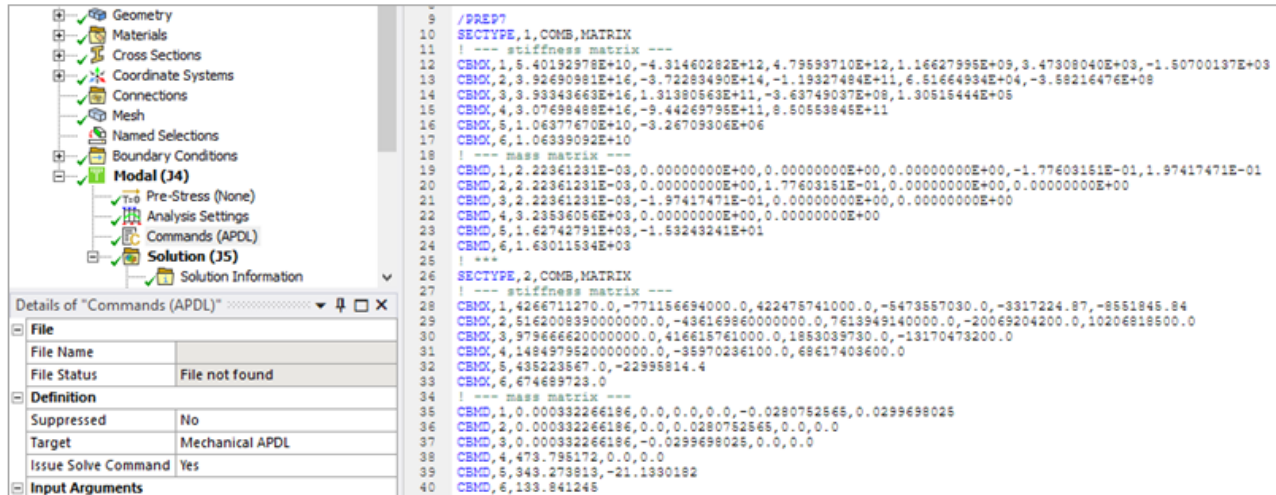

The blade is fixed on one hand and the first five frequencies are calculated. The table below compares the results of the 3D shell model and equivalent beam model.

Table 4.4: Comparison of the 3D Shell Model and Equivalent Beam Model Results

Shell	Equivalent Beam	Mode Shape	Diff. %
0.66264	0.67738	First flap	2.2%
0.69092	0.70684	First edge	2.3%
2.3553	2.3932	Second flap	1.6%
3.2611	3.32467	Second edge	1.9%
5.3698	5.472	Third flap	1.9%

The following figure shows a comparison of the mode shapes for the first and fourth frequencies.

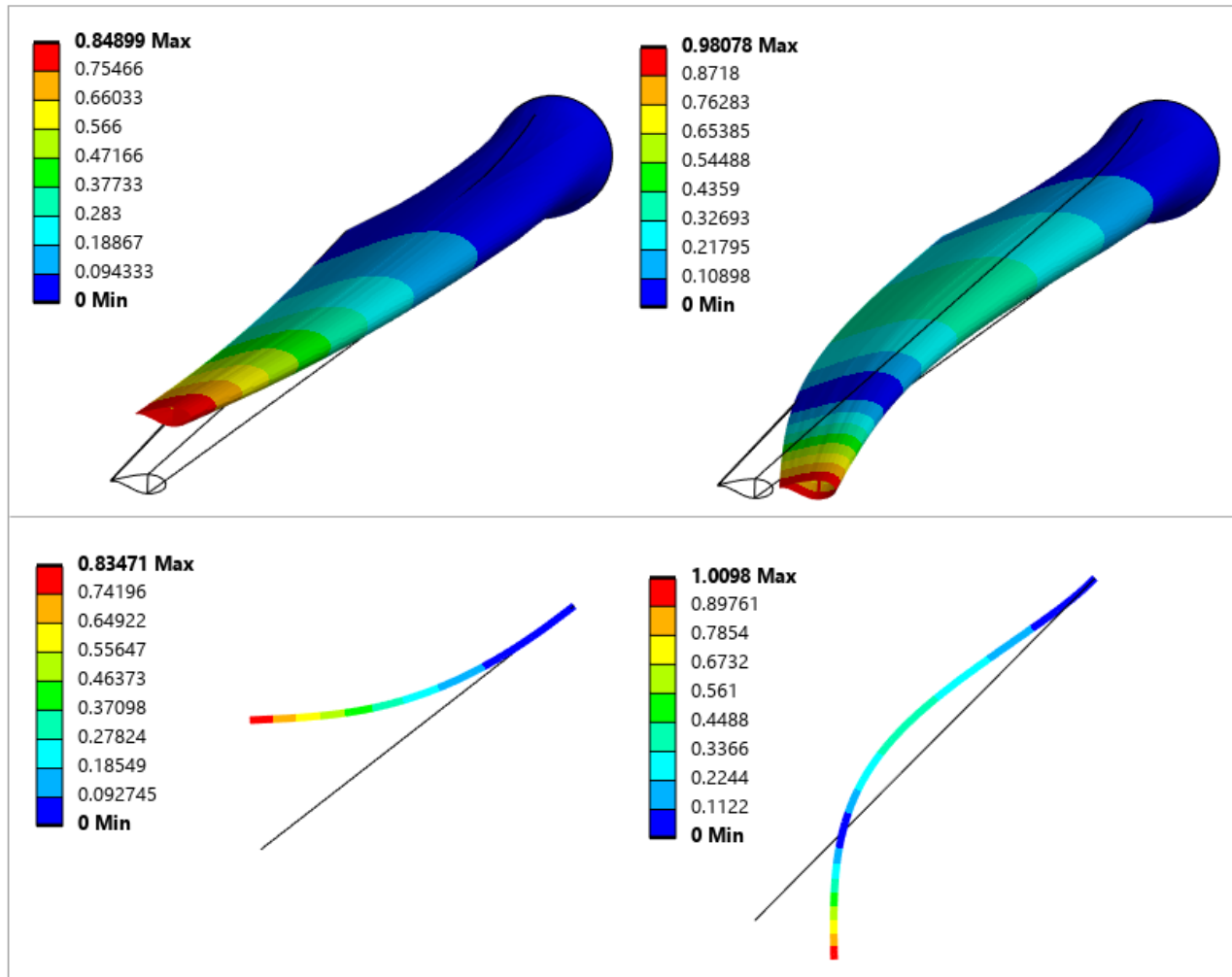

You may compare the data of the inertia properties for the 3D solid model and equivalent beam model using the reports below.

Shell Model

```

***** PRECISE MASS SUMMARY *****
TOTAL RIGID BODY MASS MATRIX ABOUT ORIGIN
  Translational mass      | Coupled translational/rotational mass
  13.811      0.0000      0.0000 | 0.0000      0.25018E+06      -103.86
  0.0000      13.811      0.0000 | -0.25018E+06      0.0000      -4287.7
  0.0000      0.0000      13.811 | 103.86      4287.7      0.0000
-----|-----
                                           Rotational mass (inertia)
                                           | 0.71960E+10      0.74359E+06      0.88257E+08
                                           | 0.74359E+06      0.72012E+10      -0.13399E+08
                                           | 0.88257E+08      -0.13399E+08      0.13162E+08

TOTAL MASS = 13.811
The mass principal axes coincide with the global Cartesian axes

CENIER OF MASS (X,Y,Z)=  -310.44      7.5198      18114.

TOTAL INERTIA ABOUT CENIER OF MASS
  0.26643E+10      0.71135E+06      0.10590E+08
  0.71135E+06      0.26682E+10      -0.11518E+08
  0.10590E+08      -0.11518E+08      0.11830E+08
    
```

Equivalent Beam Model

```

***** PRECISE MASS SUMMARY *****
TOTAL RIGID BODY MASS MATRIX ABOUT ORIGIN
      Translational mass      |      Coupled translational/rotational mass
      13.356      0.0000      0.0000 |      0.0000      0.24047E+06      -90.868
      0.0000      13.356      0.0000 |     -0.24047E+06      0.0000      -4080.8
      0.0000      0.0000      13.356 |      90.868      4080.8      0.0000
-----|-----
                                         Rotational mass (inertia)
                                         |
                                         |      0.68842E+10      0.69478E+06      0.83224E+08
                                         |      0.69478E+06      0.68891E+10      -0.12564E+08
                                         |      0.83224E+08      -0.12564E+08      0.12578E+08

TOTAL MASS = 13.356
The mass principal axes coincide with the global Cartesian axes

CENTER OF MASS (X,Y,Z)=  -305.55      6.8037      18005.

TOTAL INERTIA ABOUT CENTER OF MASS
      0.25545E+10      0.66702E+06      0.97493E+07
      0.66702E+06      0.25581E+10      -0.10928E+08
      0.97493E+07      -0.10928E+08      0.11330E+08
    
```

4.8.3. Conclusion

These two examples show that equivalent beam models, based on the ACP section cut computation, provide accurate results and significantly improve performance. The modal analysis of the beam model runs in a fraction of the time if compared with a 3D shell or solid model. This approach can also be used for other types of analysis such as transient analyses.

Chapter 5: Guide for ACP Terminology

The following terms and concepts appear in composite analyses.

Classical laminate theory (CLT) analysis

For a given sampling point, the laminate properties and stiffness/compliance matrices are evaluated based on the lay-up on the shell mesh. Also, laminate forces are calculated when a sampling point is used on a solved model where nodal displacement results are available. For more information, see [Classical Laminate Theory](#).

Coupling effect

Coupling effects describe the relationship between laminate forces and bending moments of a composite structure caused by imbalanced laminates. Classical laminate theory (CLT), by default, uses the coupling effect to calculate the polar properties and laminate engineering constants from the laminate compliance matrix. For more information, see [Analysis Options](#).

Cut-off selection rule

Acts as a cutting operation on the composite lay-up and can be defined by a geometry or a tapered edge.

Edge set

A named selection of connected edges in Mechanical are transferred to ACP as an edge set, which stores the node labels of an edge and is, therefore, not associated with the geometry. You can also define an edge set manually in ACP (Pre). For more information, see [Edge Sets \(p. 96\)](#).

Element set

A named selection of connected faces/connected elements in Mechanical are transferred to ACP as an element set, which stores the element label and is, therefore, not associated with the geometry. For more information, see [Element Sets \(p. 95\)](#).

Fabric

Associates a material with a ply, defines its thickness and optionally the fabrics cost. For more information, see [Fabric \(p. 84\)](#).

Failure criteria

Is used to evaluate the strength of a composite structure with respect to the different composite failure modes. A failure plot displays the critical margin to failure (reserve factors, inverse reserve factors, and margin of safety) to the first ply failure for a given failure criteria definition. For more information, see [Guide to Composite Failure Criteria \(p. 301\)](#).

Failure plot

Displays the margin to failure for the first ply failure of a pre-defined failure criteria definition.

Fiber direction

Describes the material 1 direction of a ply material and can be visualized on the composite model. For more information, see [Fiber Directions \(p. 28\)](#).

Geometry

The virtual 3D shape, and the derived subshapes, imported into ACP (Pre) to build complex laminates. For more information, see [Geometry \(p. 97\)](#).

Global ply number

Defines a ply's global position in the ply-ordering sequence. The global ply number represents the order of the plies in the modeling group. For more information, see [Modeling Ply Properties \(p. 142\)](#).

Inverse reserve factor (IRF)

A result type that measures the margin to failure of a composite material. For more information, see [Failure Mode Measures](#).

Lay-up

The stack of plies and their sequence in ACP. For more information, see [Lay-Up Plots \(p. 222\)](#).

Modeling ply (MP)

The MP is internal to ACP and is the most basic definition of a ply. The production ply (PP) and analysis ply (AP) are built automatically from information placed on this level. For instance, a sub laminate is an MP and each of their materials (either fabric or stackup) displays as a PP. For more information, see [Modeling Ply Properties \(p. 142\)](#).

Reference direction of an oriented selection set (OSS)

Specifies the reference direction (0°) to which all MP ply angles are relative. For more information, see [Oriented Selection Sets \(OSS\) \(p. 132\)](#).

Orthotropic elasticity

A mechanical property for linear elastic materials with direction-dependency. For more information, see [Orthotropic Elasticity](#).

Puck failure

Composite failure criterion that evaluates the strength of a reinforced material. This criterion is available in ACP. For more information, see [Puck Failure Criteria](#) and [Failure Criteria vs. Ply Type Table](#).

Sampling point

Used in pre- and post-processing to access detailed properties and results of a layup in a specific location. ACP samples through the specific element near the given coordinates to run detailed

analyses (lay-up plots, through-the-thickness plots, and laminate engineering constants). For more information, see [Sampling Points \(p. 168\)](#).

Script

Instructions in Python code that allow for more complex model definition, parametrization, and automation in ACP. Scripts are marked for execution whenever a parameter or the script itself changes. For more information, see [Scripts \(p. 71\)](#).

Selection rule

Enables you to define specific lay-up areas or ply boundaries without depending on the mesh and the geometry of the model. The selection can be combined with OSSs or MPs to define plies of arbitrary shapes. For more information, see [Selection Rules \(p. 115\)](#).

Stackup

A multiaxial stack of fabrics consisting of several plies. Typically, these layers are then stitch-bonded to form a fabric, also called a non-crimp fabric. For more information, see [Stackup \(p. 88\)](#).

Tapering

The process of progressively narrowing the thickness of an individual ply or laminate in a composite structure.

Thickness type

Determines the thickness definition when defining an MP.

T-joint

A t-joint connects two parts at right angles. It is omnipresent in composite structures.

Tsai-wu

Composite failure criterion to evaluate the strength of reinforced materials. This criterion is available in ACP. For more information, see [Tsai-Wu Failure Criterion](#) and [Failure Criteria vs. Ply Type Table](#).

Tube selection rule

A selection rule that is defined by a constant inner and outer radius along an edge. The longitudinal direction is defined by an edge set and the radii define the diameters of the inner and outer cylinder. Enabling **Include Rule Type** selects all elements between the tube's inner and outer radii. Otherwise, the elements outside the tube will be selected. For more information, see [Selection Rules \(p. 115\)](#).

Virtual geometry

Enables you to select and group specific regions or bodies of the imported CAD geometry and use them for subsequent modeling operations. All geometry-based operations are based on virtual geometries. Virtual geometries act as a reference to one or more faces or bodies of one CAD geometry. For more information, see [Virtual Geometries \(p. 101\)](#).

Warping limit

When ACP performs shape checking for element quality, solid elements with a warping factor above this user-adjustable limit are removed from the solid model. For more information, see [Element Quality](#) (p. 188).

Woven fabric

Woven fabrics consisting of fiber strands that have been woven together in two directions, also referred to as warp and weft. For more information, see [Woven Composite](#).

Bibliography

- [1] P. Camanho and L. Lambert. A design methodology for mechanically fastened joints in laminated composite materials. *Comp. Sci. Technol.*. Vol. 66. pp. 3004-3020. 2006.
- [2] P. Camanho, C. Davila, S. Pinho, I. Iannucci, and P. Robinson. Prediction of in situ strengths and matrix cracking in composites under transverse tension and in-plane shear. *Composites Part A: Applied Science and Manufacturing*. Vol. 37. No. 2. pp. 165-176. 2006.
- [3] R. Cuntze. Efficient 3D and 2D failure conditions for UD laminae and their application within the verification of the laminate design. *Comp. Sci. Technol.*. Vol. 66. No. 7-8. pp. 1081-1096. 2006.
- [4] C. Davila, P. Camanho, and C. Rose. Failure Criteria for FRP Laminates. *Journal of Composite Materials*. Vol. 39. No. 4. 2005.
- [5] Structural Materials Handbook. ECSS-HB-304. ESA2009ESA Publications Division. 2009.
- [6] G. L. Ghiringhelli and P. Mantegazza. Linear, straight and untwisted anisotropic beam section properties from solid finite elements. *Composites Engineering*. Vol. 4. No. 12. pp. 1-13. 1994.
- [7] V. Giavotto, M. Borri, P. Mantegazza, G. Ghiringhelli, V. Carmaschi, G. C. Maffioli, and F. Mussi. Anisotropic beam theory and applications. *Computers & Structures*. Vol. 16. No. 1-4. pp. 403-413. 1983.
- [8] O. Hoffman. The Brittle Strength of Orthotropic Materials. *Journal of Composite Materials*. Vol. 1. pp. 200-206. 1967.
- [9] A. Puck. Festigkeitsanalyse von Faser-Matrix-Laminaten. Carl Hanser. 1996.
- [10] P.D. Soden, A.S. Kaddour, and M.J. Hinton. Recommendations for designers and researchers resulting from the world-wide failure exercise. *Composites Science and Technology*. Vol. 64. No. 3-4. pp. 589-604. March, 2004.

