



Twin Builder Components: Hydraulic



ANSYS, Inc.
Southpointe
2600 Ansys Drive
Canonsburg, PA 15317
ansysinfo@ansys.com
<https://www.ansys.com>
(T) 724-746-3304
(F) 724-514-9494

Release 2024 R2
July 2024

ANSYS, Inc. and
ANSYS Europe,
Ltd. are UL
registered ISO
9001:2015 com-
panies.

Copyright and Trademark Information

© 1986-2024 ANSYS, Inc. Unauthorized use, distribution or duplication is prohibited.

ANSYS, Ansys Workbench, AUTODYN, CFX, FLUENT and any and all ANSYS, Inc. brand, product, service and feature names, logos and slogans are registered trademarks or trademarks of ANSYS, Inc. or its subsidiaries located in the United States or other countries. ICM CFD is a trademark used by ANSYS, Inc. under license. All other brand, product, service and feature names or trademarks are the property of their respective owners. FLEXIm and FLEXnet are trademarks of Flexera Software LLC.

Disclaimer Notice

THIS ANSYS SOFTWARE PRODUCT AND PROGRAM DOCUMENTATION INCLUDE TRADE SECRETS AND ARE CONFIDENTIAL AND PROPRIETARY PRODUCTS OF ANSYS, INC., ITS SUBSIDIARIES, OR LICENSORS. The software products and documentation are furnished by ANSYS, Inc., its subsidiaries, or affiliates under a software license agreement that contains provisions concerning non-disclosure, copying, length and nature of use, compliance with exporting laws, warranties, disclaimers, limitations of liability, and remedies, and other provisions. The software products and documentation may be used, disclosed, transferred, or copied only in accordance with the terms and conditions of that software license agreement.

ANSYS, Inc. and ANSYS Europe, Ltd. are UL registered ISO 9001: 2015 companies.

U.S. Government Rights

For U.S. Government users, except as specifically granted by the ANSYS, Inc. software license agreement, the use, duplication, or disclosure by the United States Government is subject to restrictions stated in the ANSYS, Inc. software license agreement and FAR 12.212 (for non-DOD licenses).

Third-Party Software

See the legal information in the product help files for the complete Legal Notice for Ansys proprietary software and third-party software. If you are unable to access the Legal Notice, please contact ANSYS, Inc.

Table of Contents

Table of Contents	Contents-1
1 - Multiphysics: Hydraulic Library	1-2
Hydraulic Reference Arrow System	1-4
Across and Through Quantity of the Fluidic Domain	1-5
Accumulators	1-6
Gas-Charged Isothermal Accumulator	1-7
Spring-Loaded Accumulator	1-11
Gas-Charged Adiabatic Accumulator	1-16
Actuators	1-20
Double-Acting Actuator	1-21
Equal Movement Cylinder	1-29
Single-Acting Actuator	1-33
Measurement	1-37
Manometer	1-38
Manometer (1Pin)	1-39
Flowmeter	1-42
Wattmeter	1-43
Orifices	1-44
Annular Orifice	1-45
Sharp-Edge Orifice	1-49
Turbulent Orifice	1-54
Variable Orifice	1-57
Laminar Orifice	1-63
Characteristic Orifice	1-64
Passive Elements	1-67
Volume	1-68
Pipe	1-69
Blind Plug	1-74

Hydraulic Sources	1-77
Pressure Source	1-78
Pump	1-79
Flow Source	1-84
Hydraulic Switches	1-85
Limit Switch 1	1-86
Limit Switch 2	1-88
Limit Switch 3	1-90
Limit Switch 4	1-92
Ideal Switch, Normally Closed	1-94
Ideal Switch, Change Over	1-97
Ideal Switch, Normally Open	1-101
Pressure Switch	1-104
Hydraulic Valves	1-107
Directional Control Valves	1-108
Directional Control Valves, 2-2	1-110
Directional Control Valves, 3-2	1-114
Directional Control Valves, 4-2	1-118
Directional Control Valves, 4-3	1-125
Non-Return Valves	1-130
Non-Return-Valve, Spring-Loaded	1-131
Pressure Control Valves	1-135
Pressure Relief Valve	1-136
Index	Index-1

1 - Multiphysics: Hydraulic Library

Hydraulic equipment and models are operated (or powered) by the resistance offered or the pressure transmitted when a quantity of liquid (such as water or oil) is forced through a comparatively small orifice or through a tube. Devices within this family derive their power from pressurized flow, or are designed to maintain, measure, restrict, or filter the pressurized flow.

Hydraulic models have a permanent place in modern drive technology. As is not the case with electric or pneumatic drives, the project designer must design and dimension the power source (pump unit) as well as the actuators (cylinders or motors). Since the hydraulic pump is a flow source, simultaneous operation of multiple loads requires corresponding decoupling components to create a constant pressure source to minimize the mutual effect of the drives. Additionally, since the control principles of hydraulics are based almost without exception on flow resistances, for example the pressure loss in the resistance through which the oil flows, the resulting quantity of heat as energy loss becomes particularly important. At higher power, circuits with actuating pumps combined with hydraulic fluid reservoirs have a special role.

The hydraulic library provides all essential models of hydraulic drives for building complex circuits: accumulators, actuators, measurement devices, orifices, passive elements, sources, switches, and valves. The models, represented by the symbols according to DIN ISO 1219, simulate the stationary behavior, that means the state magnitudes (pressure, oil flow, speeds and so on) are calculated according to the laws of hydraulic for the steady state and shown graphically. The models simulate possible oscillations and instabilities, which can occur in practice as the result of volume compressibility and masses.

To limit the parameter number of models only typical properties are calculated (e.g. delivery flow reduction of pumps with increasing delivery pressure as the result of volumetric efficiency).

The hydraulic models do not support AC and DC analysis.

By default, models and wires of the fluidic domain are represented in green in the graphical representation of the Schematic. Select Sheet>Properties to change the wire color of the domain. You can only change the wire color. The symbol color is not affected by the setting.

To define parameter values, most of the hydraulic models use a dialog with a simple listing of the used parameters. Some hydraulic models use special wizards for parameter input.

In general, all parameters of hydraulic models can be changed during simulation. Only initial values are set only once at the start of the simulation.

The Hydraulic library consists of the following types of models:

- [Accumulators](#)
- [Actuators](#)
- [Measurement](#)
- [Orifices](#)
- [Passive Elements](#)
- [Sources](#)

- [Switches](#)
- [Valves](#)

[Top](#)

References

- [1] Fitch, E.C. and I.T. Hong. *Hydraulic Component Design and Selection*, BarDyne, Inc., 1997.
- [2] Keller, George. *Hydraulic System Analysis, Hydraulics and Pneumatics*. Second Edition, 1974.
- [3] Merritt, Herbert. *Hydraulic Control Systems*. John Wiley & Sons, Inc., 1967.
- [4] Will, Dieter, et al. *Hydraulik, Grundlagen, Komponenten, Schaltungen*. Springer Verlag, 1999.

Hydraulic Reference Arrow System

The direction of Positive current and voltage is marked by the red point or the plus sign at the symbol of electrical components as shown in the table.

	Difference Sources	Flow Sources	Passive Components
Fluidic			

Across and Through Quantity of the Fluidic Domain

Across	Through	Equation
Pressure [Pa]	Flow Rate [m ³ /s]	$q(t) = K \cdot p(t)$

The fluidic domain uses the pressure as Across and the flow rate as Through quantity.

Accumulators

A hydraulic accumulator stores potential power (liquid under pressure) for future conversion into work. This work can be used for operating cylinders and fluid motors, maintaining the required system pressure in case of pump or power failure, and compensating for pressure loss due to leakage. Accumulators are used mainly on the lift equipment to provide positive clamping action on heavy loads when a pump's flow is diverted to lifting or other operations.

Accumulators can prevent pump and actuator damage by acting as a shock absorber in systems where spiking or wide pressure variations occur faster than a relief valve can respond.

The hydraulic library provides two types of accumulators: a spring-loaded type and two gas-charged variants. The spring-loaded accumulator uses the energy stored in a spring to create a constant force on the liquid, the gas-charged types use the compressibility of a gas (nitrogen).

- [Gas-Charged Isothermal Accumulator \(ACC_ISO\)](#)
- [Spring-Loaded Accumulator \(ACC_SPR\)](#)
- [Gas-Charged Adiabatic Accumulator \(ACCU_ADIA\)](#)

Gas-Charged Isothermal Accumulator

Library: Hydraulic	Modeling Language: SML	Version Number: Twin Builder 2024.2
--------------------	------------------------	-------------------------------------

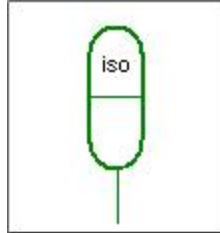

Figure 1. Component symbol

- [Description](#)
- [Assumptions and Limitations](#)
- [Mathematical Description](#)
- [Netlist Syntax](#)
- [Conservative Pins](#)
- [Parameters](#)
- [Input/Output Quantities](#)
- [Example](#)
- [References](#)

Description

The model represents an Isothermal Accumulator that uses the compressibility of gas (nitrogen). The change in the gas volume takes place so slowly that there is sufficient time for the complete heat exchange to take place between the gas and its surroundings. The result is a constant temperature.

The hydraulic fluid reservoir is a tank with a gas-filled (for example nitrogen) rubber bladder. If system pressure is applied, the gas is compressed, so that fluid is stored in the tank. When the system pressure falls, the gas bladder forces the stored fluid volume back into the system. This achieves a storage effect corresponding to the effect of a large capacitor in electrical circuits.

[Top](#)

Assumptions and Limitations

The model is based on the following assumptions:

- The gas temperature is constant at ambient temperature.
- Loading on the separator, such as inertia, friction, and so on, is not considered.

- Fluid compressibility is not taken into account.

[Top](#)

Mathematical Description

The following equations are used to model isothermal state change of the gas:

$$const = P_{GAS} \cdot VOL = P \cdot (VOL - VOL_FLUID)$$

$$P_{GAS}(VOL_FLUID=0) = CHARGE$$

$$P(t=0) = P_0$$

This state change occurs when the reservoir is filled and emptied slowly (> 3 minutes, for example to equalize leakage losses in tensioning devices).

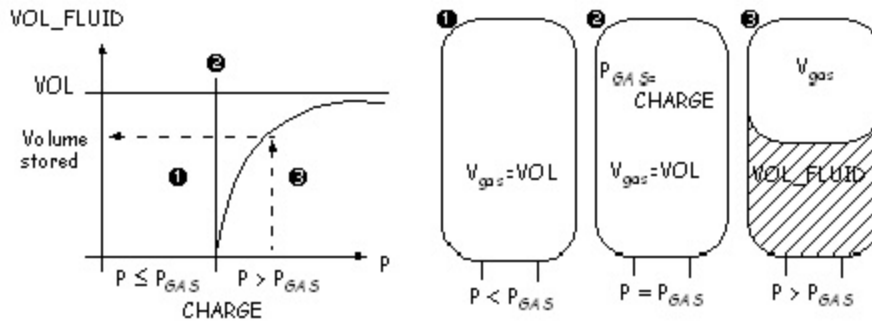

Figure 2. Three working conditions of the Gas-Charged Isothermal Accumulator

[Top](#)

Netlist Syntax

```
MODEL ACC_ISO ?InstanceName(@InstanceName):(@ (Refbase)@(ID)) H1:= %0 ( VOL:=
@VOL, P0:= @P0, CHARGE:= @CHARGE, B:= @B) SRC: DB(Lib:=@ModelLibraryName);
```

[Top](#)

Conservative Pins

Table 1

Name	Port/Terminal description	Nature/Data type
H1	Fluidic Pin	Fluidic terminal

[Top](#)

Parameters

Table 2

Name	Description	Data Type	Default Value [Unit]
VOL	Accumulator Capacity	real	10m [m ³]
P0	Initial Fluid Pressure	real	0 [Pa]
CHARGE	Gas Pre-charge Pressure	real	0.1Meg [Pa]
B	Bulk Modulus	real	1G [pa]

[Top](#)

Input/Output Quantities

Table 3

Name	Description [Unit]	Direction	Data Type
P	Fluid Pressure [Pa]	Output	real
VOL_FLUID	Fluid Volume [m ³]	Output	real

[Top](#)

Example

In this example, the Gas-Charged Isothermal Accumulator is discharged by a laminar orifice. The typical pressure drop is observed up emptying of the fluid. The schematic of the example is shown in Figure 3, system parameters listed in Table 4 and the simulation results are shown in Figure 4.

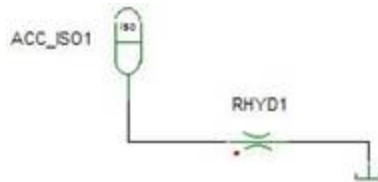

Figure 3. Application example of the Gas-Charged Isothermal Accumulator

Table 4. System Parameters

Component	Parameter	Value [unit]
Gas-Charged Isothermal Accumulator ACC_ISO1	VOL	1m [m ³]
	P0	10Meg [Pa]
	CHARGE	5Meg [Pa]

	B	1E9 [Pa]
Linear Orifice RHYD1	Conductance	1n [m ³ / (Pa s)]

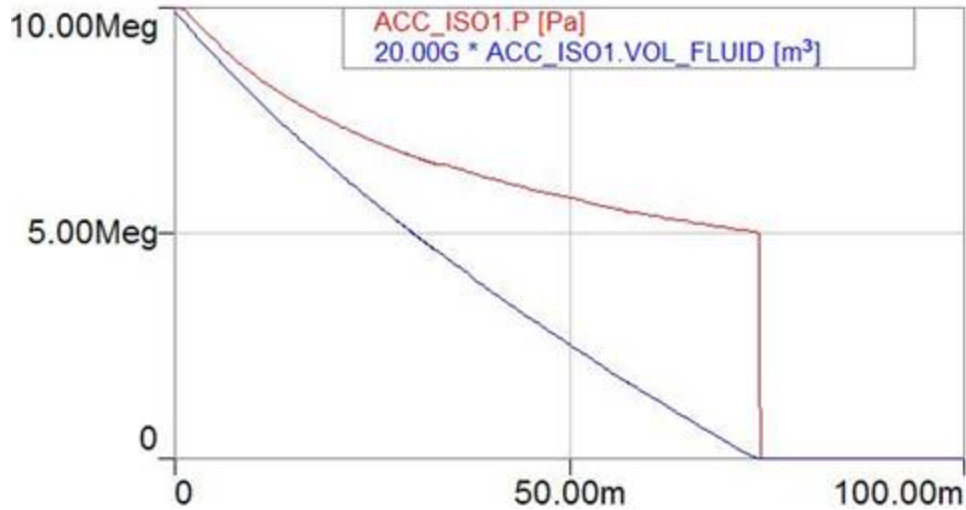

Figure 4. Simulation results – fluid pressure and volume of the Gas-Charged Isothermal Accumulator

[Top](#)

References

Spring-Loaded Accumulator

Library: Hydraulic	Modeling Language: SML	Version Number: Twin Builder 2024.2
--------------------	------------------------	-------------------------------------

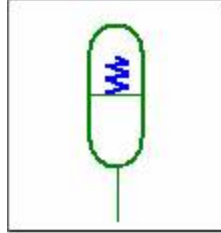

Figure 1. Component symbol

- [Description](#)
- [Assumptions and Limitations](#)
- [Mathematical Description](#)
- [Netlist Syntax](#)
- [Conservative Pins](#)
- [Parameters](#)
- [Input/Output Quantities](#)
- [Example](#)
- [References](#)

Description

The Spring-Loaded Accumulator represents an accumulator that uses the energy stored in a spring to create a constant force on the liquid. If system pressure is applied, the spring is compressed, so that fluid is stored in the tank. When the system pressure falls, the spring forces the stored fluid volume back into the circuit. This achieves a storage effect corresponding to the effect of a large capacitor in electrical circuits.

[Top](#)

Assumptions and Limitations

The model is based on the following assumptions:

- The spring has linear characteristics.
- No loading on the separator, such as inertia, friction, and so on, is considered.
- Fluid compressibility is not taken into account.

[Top](#)

Mathematical Description

The Spring-Loaded Accumulator can be described using the following set of equations:

$$AREA = \frac{\pi}{4} \cdot DIA^2$$

$$VOL(t) = VOL0 + S \cdot AREA$$

$$F_PRE = CHARGE \cdot AREA$$

$$Q = V \cdot AREA + \frac{VOL(t)}{B} \cdot \frac{dP}{dt}$$

$$P \cdot AREA - C \cdot S - KVSC \cdot V - F_PRE = M \frac{dV}{dt}$$

where F_PRE is the pre-charge spring force.

The three working conditions of the Spring-Loaded Accumulator described earlier are illustrated in Figure 2 (F stands for spring force). The piston movement is limited by $STROKE$.

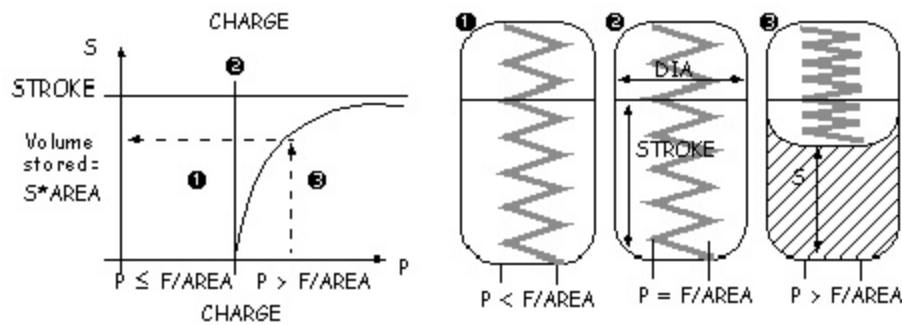

Figure 2. Three working conditions of the Spring-Loaded Accumulator

[Top](#)

Netlist Syntax

```
MODEL ACC_SPR ?InstanceName(@InstanceName):(@@(@Refbase)@(ID)) H1:= %0 ( DIA:=
@DIA, STROKE:= @STROKE, M:= @M, C:= @C, CHARGE:= @CHARGE, KVSC:= @KVSC,
B:= @B, VOL0:= @VOL0) SRC: DB(Lib:=@ModelLibraryName);
```

[Top](#)

Conservative Pins

Table 1

Name	Port/Terminal description	Nature/Data type
H1	Fluidic Pin	Fluidic terminal

[Top](#)

Parameters

Table 2

Name	Description	Data Type	Default Value [Unit]
DIA	Piston diameter	real	10m [m]
STROKE	Piston stroke	real	10m [m]
M	Piston mass	real	1m [kg]
C	Spring rate	real	1K [N/m]
CHARGE	Pre-charge pressure	real	0.1Meg [Pa]
VOL0	Initial volume	real	1u [m ³]
B	Bulk modulus	real	1G [Pa]
KVSC	Viscous friction coefficient	real	1 [N s/m]

[Top](#)

Input/Output Quantities

Table 3

Name	Description [Unit]	Direction	Data Type
P	Fluid pressure [Pa]	Output	real
Q	Flow rate [m ³ /s]	Output	real
S	Position [m]	Output	real
V	Velocity [m/s]	Output	real
VOL_FLUID	Fluid volume [m ³]	Output	real

[Top](#)

Example

In this example, the Spring-Loaded Accumulator is charged by a constant flow source. The pressure increases significantly when the accumulator spring reaches its limit. The schematic of the example is shown in Figure 3, system parameters are listed in the table 4, and the simulation results are shown in Figure 4.

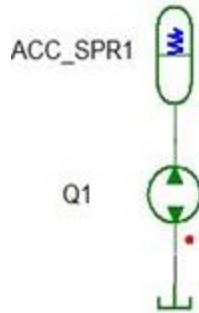

Figure 3. Application example of the Spring-Loaded Accumulator

Table 4. System Parameters

Component	Parameter	Value [unit]
Spring-Loaded Accumulator ACC_SPR1	DIA	100m [m]
	STROKE	100m [m]
	M	0 [kg]
	C	100K [N/m]
	CHARGE	3Meg [Pa]
	VOL0	0.4m [m ³]
	B	1G [Pa]
	KVSC	0 [N s/m]
Flow Source Q1	Value	100u [m ³ /s]

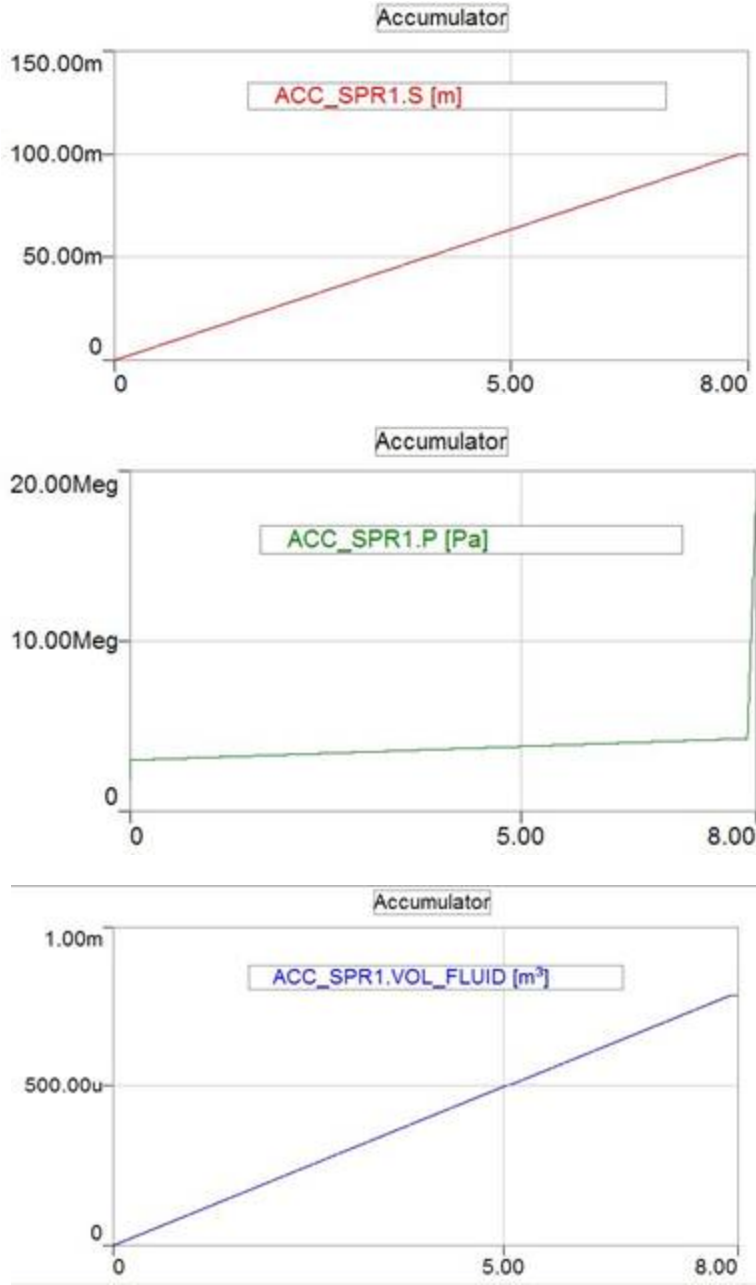

Figure 4. Simulation results – fluid volume, position and fluid pressure of the Spring-Loaded Accumulator

[Top](#)

References

Gas-Charged Adiabatic Accumulator

Library: Hydraulic	Modeling Language: SML	Version Number: Twin Builder 2024.2
--------------------	------------------------	-------------------------------------

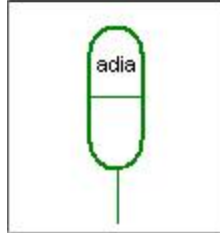

Figure 1 . Component symbol

- [Description](#)
- [Assumptions and Limitations](#)
- [Mathematical Description](#)
- [Netlist Syntax](#)
- [Conservative Pins](#)
- [Parameters](#)
- [Input/Output Quantities](#)
- [Example](#)
- [References](#)

Description

The model represents an Adiabatic Accumulator that uses the compressibility of gas (nitrogen). The change of state in the gas volume takes place so rapidly that the temperature of the gas also changes.

The hydraulic fluid reservoir is a tank with a gas-filled (for example nitrogen) rubber bladder. If system pressure is applied, the gas is compressed, so that fluid is stored in the tank. When the system pressure falls, the gas bladder forces the stored fluid volume back into the circuit. This achieves a storage effect corresponding to the effect of a large capacitor in electrical circuits.

[Top](#)

Assumptions and Limitations

The model is based on the following assumptions:

- There is no heat transfer from the gas.
- Loading on the separator, such as inertia, friction, and so on, is not considered.
- Fluid compressibility is not taken into account.

[Top](#)

Mathematical Description

The following equations are used to model adiabatic state change of the gas:

$$\text{const} = P_{\text{gas}} \cdot \text{VOL}^{\kappa} = P \cdot (\text{VOL} - \text{VOL_FLUID})^{\kappa}$$

$$\kappa = 1, 4$$

$$P_{\text{gas}}(\text{VOL_FLUID}=0) = \text{CHARGE}$$

$$P(t=0) = P_0$$

This state change occurs when the reservoir is filled and emptied quickly.

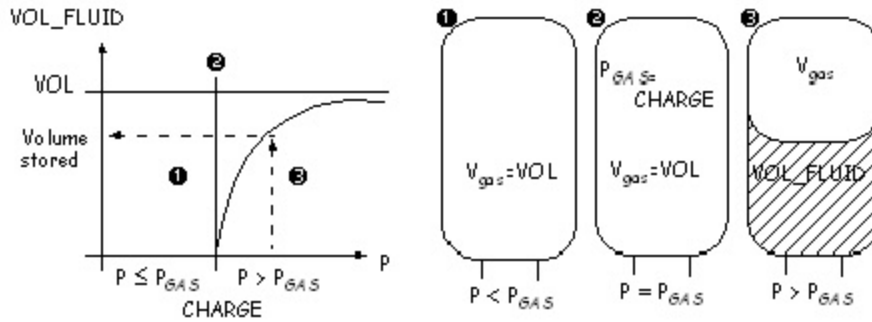

Figure 2. Three working conditions of the Gas-Charged Adiabatic Accumulator

[Top](#)

Netlist Syntax

```
MODEL ACCU_ADIA ?InstanceName(@InstanceName):(@ (Refbase)@ (ID)) H1:= %0 ( VOL:=
@VOL, P0:= @P0, CHARGE:= @CHARGE, B:= @B) SRC: DB(Lib:=@ModelLibraryName) ;
```

[Top](#)

Conservative Pins

Table 1

Name	Port/Terminal description	Nature/Data type
H1	Fluidic Pin	Fluidic terminal

[Top](#)

Parameters

Table 2

Name	Description	Data Type	Default Value [Unit]
VOL	Accumulator Capacity	real	10m [m ³]
P0	Initial Fluid Pressure	real	0 [Pa]
CHARGE	Gas Pre-charge Pressure	real	0.1Meg [Pa]
B	Bulk Modulus	real	1G [pa]

[Top](#)

Input/Output Quantities

Table 3

Name	Description [Unit]	Direction	Data Type
P	Fluid Pressure [Pa]	Output	real
VOL_FLUID	Fluid Volume [m ³]	Output	real

[Top](#)

Example

In this example, the Gas-Charged Adiabatic Accumulator is discharged by a laminar orifice. The typical pressure drop is observed up emptying of the fluid. The schematic of the example is shown in Figure 3, system parameters listed in Table 4 and the simulation results are shown in Figure 4.

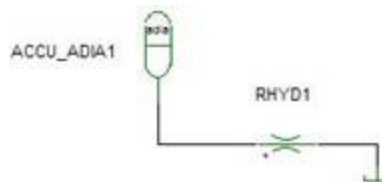

Figure 3. Application example of the Gas-Charged Adiabatic Accumulator

Table 4. System Parameters

Component	Parameter	Value [unit]
Gas-Charged Adiabatic Accumulator ACC_ADIA1	VOL	1m [m ³]
	P0	10Meg [Pa]
	CHARGE	5Meg [Pa]
	B	1E9 [Pa]

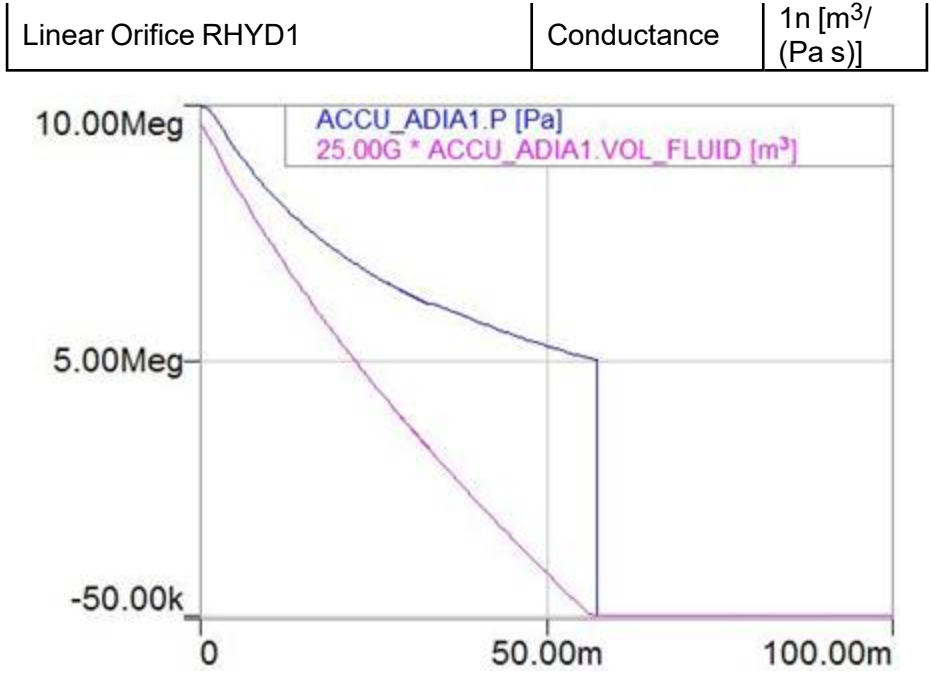

Figure 4. Simulation results – fluid pressure and volume of the Gas-Charged Adiabatic Accumulator

[Top](#)

References

Actuators

A hydraulic actuator converts fluid power into mechanical force and motion. Cylinders, motors, and turbines are the most common types of actuating devices used in fluid power systems.

The hydraulic library provides three cylinder actuators with limits and friction characteristic: a single-acting actuator, a double-acting actuator, and an equal movement cylinder. An actuating cylinder is a device that converts fluid power to linear, or straight line, force and motion. The cylinder consists of a piston operating within a cylindrical bore. The following figure shows the used Stick-Slip characteristic.

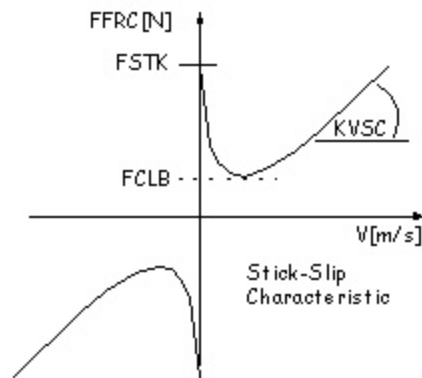

Figure 1. Stick-slip characteristics of the Cylinder Actuators

The single-acting actuator applies fluid power only in one direction. To move the piston back into the cylinder a mechanical force can be applied. The double-acting actuator and equal movement cylinder applies fluid power in both directions.

- [Double-Acting Actuator \(DOUBLE_ACT\)](#)
- [Equal Movement Cylinder \(DOUBLE_CYL\)](#)
- [Single-Acting Actuator \(SINGLE_ACT\)](#)

Double-Acting Actuator

Library: Hydraulic	Modeling Language: SML	Version Number: Twin Builder 2024.2
--------------------	------------------------	-------------------------------------

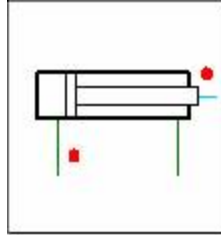

Figure 1 . Component symbol

- [Description](#)
- [Assumptions and Limitations](#)
- [Mathematical Description](#)
- [Netlist Syntax](#)
- [Conservative Pins](#)
- [Parameters](#)
- [Input/Output Quantities](#)
- [Example](#)
- [References](#)

Description

The model represents a Double-Acting Actuator with limits and stick-slip-characteristic. The model applies fluid power in both directions. In addition, a mechanical force can be applied.

The multidomain model has two fluid ports to apply the fluid powers and one translational port to apply the mechanical force. The used mechanical domain is the translational displacement-force representation.

[Top](#)

Assumptions and Limitations

The model is based on the following assumptions:

- Leakage, internal or external, is not taken into account.
- Loading on piston rod, such as inertia, friction, spring, and so on, is taken into account.

[Top](#)

Mathematical Description

The model calculating the damping areas is identical to the Limit Stop model in the Basics library. The upper limit corresponds to the *STROKE* value, the lower limit is equal to $S=0$.

$$Q1 = V \cdot AREA1 + CHYD1 \cdot \frac{d}{dt}P1$$

$$Q2 = V \cdot AREA2 - CHYD2 \cdot \frac{d}{dt}P2$$

$$AREA1 = \frac{\pi}{4} \cdot DIA1^2$$

$$AREA2 = \frac{\pi}{4} \cdot (DIA1^2 - DIA2^2)$$

$$CHYD1 = \frac{VOL0_1 + \Delta S \cdot AREA1}{B}$$

$$CHYD2 = \frac{VOL0_2 + (STROKE - \Delta S) \cdot AREA2}{B}$$

$$M \cdot ACC = P(H1) \cdot AREA1 - P(H2) \cdot AREA2 - FFRC + F(TRB1)$$

$$FFRC = \text{sgn}(v) \cdot \left((FSTK - FCLB) \cdot e^{-\frac{|V|}{K}} + FCLB + KVSC \cdot |V| \right)$$

Friction: Stick Coulomb Viscous

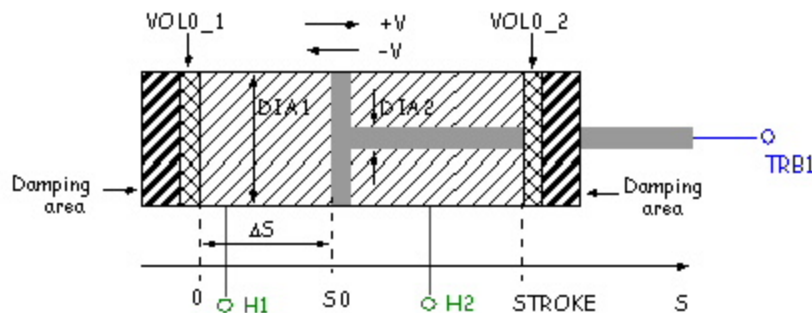

Figure 2 . Structure of the Double-Acting Actuator

[Top](#)

Netlist Syntax

```
MODEL DOUBLE_ACT ?InstanceName(@InstanceName):(@ (Rebase)@(ID)) H1:= %0,
TRB1:= %1, H2:= %2 ( S0:= @S0, STROKE:= @STROKE, M:= @M, B:= @B, VOL0_1:=
@VOL0_1, DAMPING:= @DAMPING, VOL0_2:= @VOL0_2, DIA1:= @DIA1, DIA2:= @DIA2,
KVSC:= @KVSC, C:= @C, V0:= @V0, FCLB:= @FCLB, FSTK:= @FSTK, K:= @K) SRC: DB
(Lib:=@ModelLibraryName) ;
```

[Top](#)

Conservative Pins

Table 1

Name	Port/Terminal description	Nature/Data type
H1	Fluidic Pin	Fluidic terminal
H2	Fluidic Pin	Fluidic terminal
TRB1	Translational Mechanical Pin	Mechanical terminal

[Top](#)

Parameters

Table 2

Name	Description	Data Type	Default Value [Unit]
DIA1	Piston Diameter	real	50m [m]
DIA2	Piston Rod Diameter	real	10m [m]
STROKE	Piston Stroke	real	0.1 [m]
M	Piston Mass	real	1 [kg]
KVSC	Viscous Friction Coefficient	real	0.1k [N s/m]
K	Slop Coefficient	real	1 [m/s]
FSTK	Slip Friction Force	real	0 [N]
FCLB	Coulomb Friction Force	real	0 [N]
VOL0_1	Initial Volume at H1	real	1u [m ³]
VOL0_2	Initial Volume at H2	real	1u [m ³]
B	Bulk Modulus	real	1G [Pa]
C	Spring Rate (Limit)	real	1Meg [N/m]
DAMPING	Damping Coefficient (Limit)	real	1Meg [N s/m]

S0	Initial Position	real	0 [m]
V0	Initial Velocity	real	0 [m/s]

[Top](#)

Input/Output Quantities

Table 3

Name	Description [Unit]	Direction	Data Type
S	Position [m]	Output	real
V	Velocity [m/s]	Output	real
ACC	Acceleration [m/s ²]	Output	real
FFRC	Friction Force [N]	Output	real

[Top](#)

Example

This example demonstrates the acceleration, rerouting and deceleration of a Double-Acting Actuator. After the piston position reaches 5mm, a force is applied to act against the movement of the piston. The valve is controlled by a state diagram. The schematic of the example is shown in Figure 3, system parameters listed in Table 4 and the simulation results are shown in Figure 4.

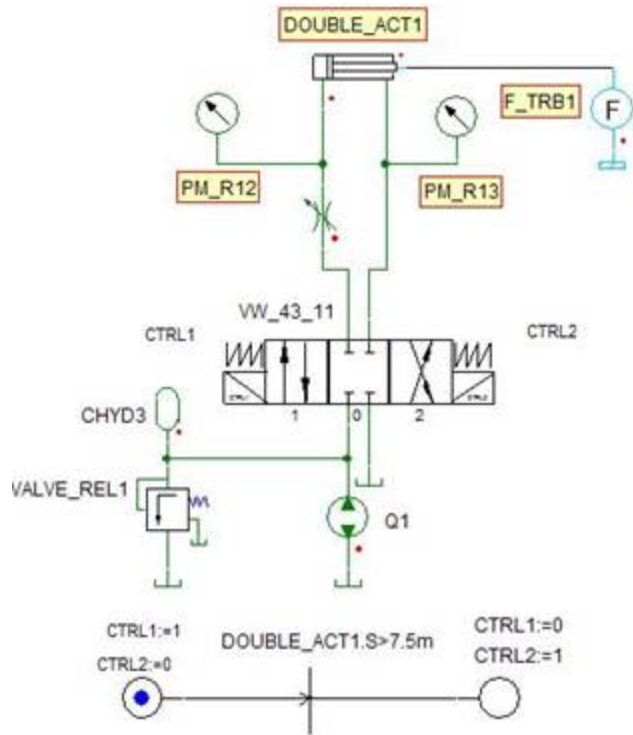
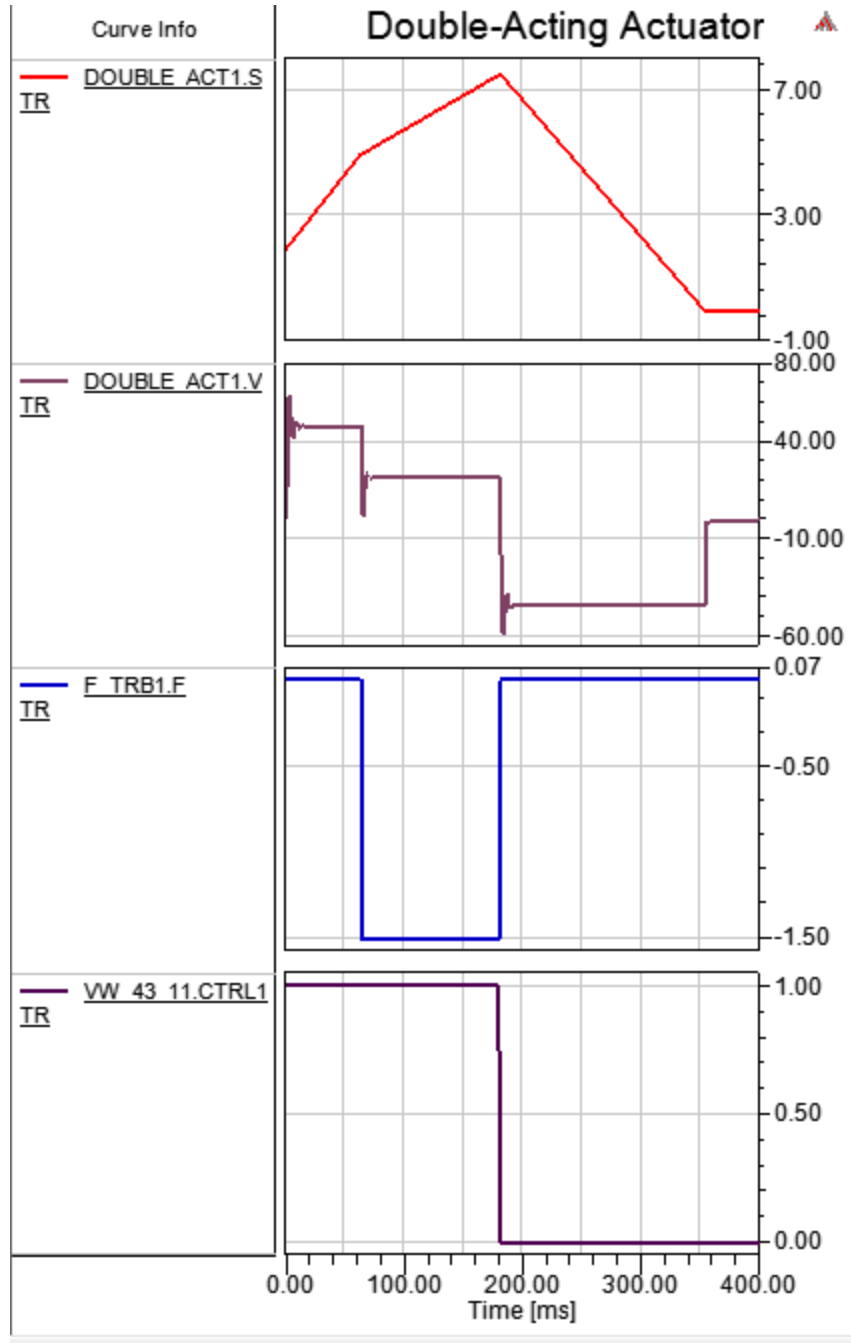

Figure 3. Application example of the Double-Acting Actuator

Table 4. System Parameters

Component	Parameter	Value [unit]
Double-Acting Actuator DOUBLE_ACT1	DIA1	50m [m ³]
	DIA2	20m [m ³]
	STROKE	0.02 [m]
	M	30 [Kg]
	KVSC	5K [N s/m]
	K	1 [m/s]
	FSTK	0 [N]
	FCLB	0 [N]
	VOL0_1	0.1m [m ³]
	VOL0_2	0.1m [m ³]
	B	1G [Pa]
	C	100Meg [N/m]
	DAMPING	1Meg [N s/m]

	S0	0.002 [m]
	V0	0 [m/s]
Force Source F_TRB1	Value	-1500*(DOUBLE_ACT1.S>5m AND DOUBLE_ACT1.V>0) [N]
Turbulent OR_TURB1	CONDUCTANCE	0.1u [m ³ /s*Pa ^{0.5}]
Directional Control Valves (4-3, Function 1) VW_43_11	CTRL1	CTRL1
	CTRL2	CTRL2
Hydraulic Capacitance CHYD3	VOL	0.5Meg [m ³]
	B	1G [Pa]
	P0	1Meg [Pa]
Pressure Controlled Valve (Pressure Relief) VALVE_REL1	PSET	1Meg [Pa]
	SLOPE	1Meg [Pa s/m ³]
Flow Source Q1	VALUE	500u



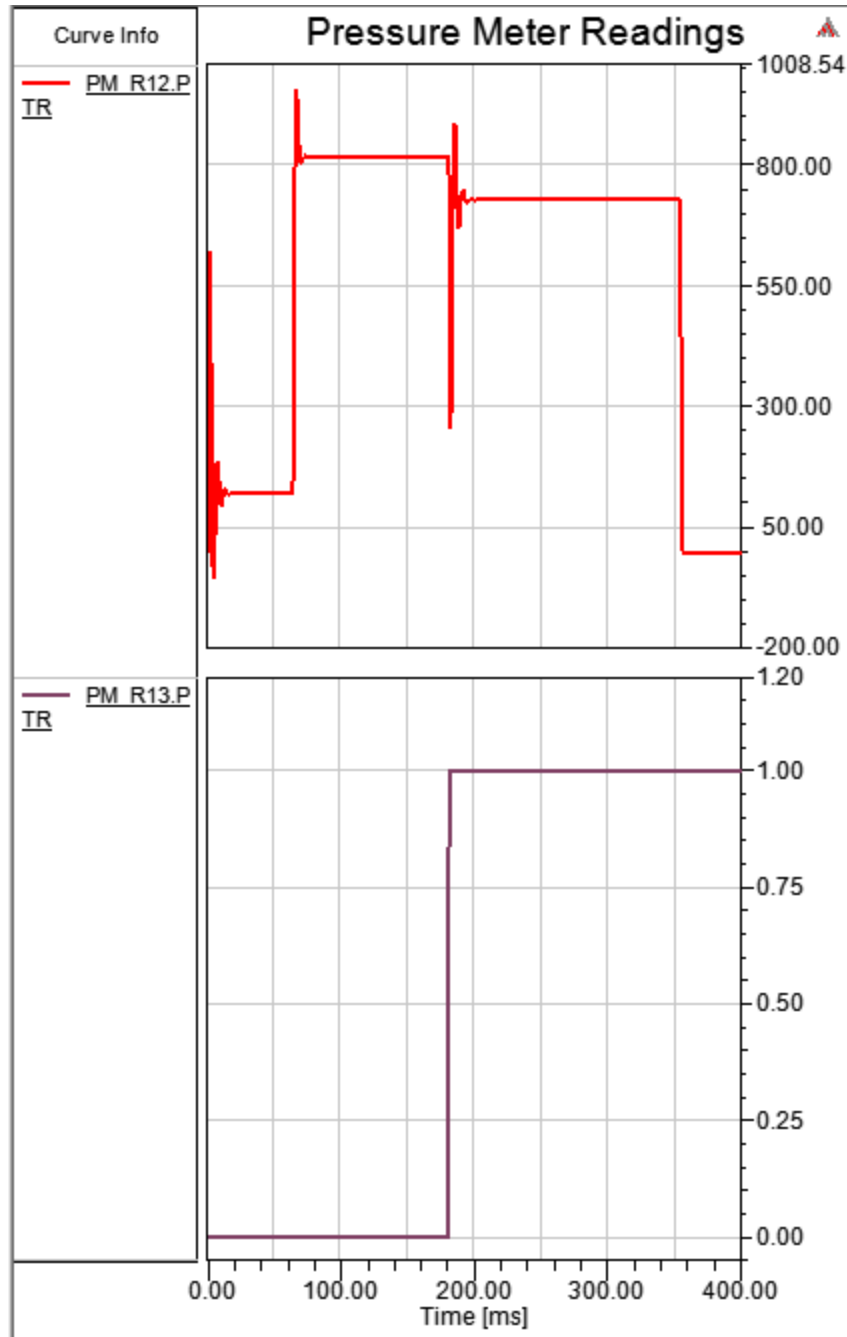

Figure 4. Simulation results

[Top](#)

References

See *Limit Stop* in the Basic Elements Library help.

Equal Movement Cylinder

Library: Hydraulic	Modeling Language: SML	Version Number: Twin Builder 2024.2
--------------------	------------------------	-------------------------------------

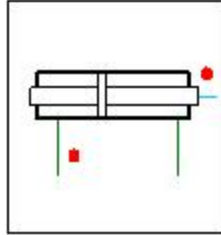

Figure 1 . Component symbol

- [Description](#)
- [Assumptions and Limitations](#)
- [Mathematical Description](#)
- [Netlist Syntax](#)
- [Conservative Pins](#)
- [Parameters](#)
- [Input/Output Quantities](#)
- [Example](#)
- [References](#)

Description

The Equal Movement Cylinder model represents an Equal Movement Cylinder with limits and stick-slip-characteristic. The model applies fluid power in both directions. Because of the cylinder design, the pressure areas are identical for both directions. In addition, a mechanical force can be applied.

The multidomain model has two fluid ports to apply the fluid powers and one translational port to apply the mechanical force. The translational displacement-force representation of the mechanical domain is used.

[Top](#)

Assumptions and Limitations

The model is based on the following assumptions:

- Leakage, internal or external, is not taken into account.
- Loading on piston rod, such as inertia, friction, spring, and so on, is taken into account.

[Top](#)

Mathematical Description

The model calculating the damping areas is identical to the Limit Stop model in the Basics library. The upper limit corresponds with the STROKE value, the lower limit is equal to S=0.

$$Q1 = V \cdot AREA + CHYD1 \cdot \frac{d}{dt}P1$$

$$Q2 = V \cdot AREA - CHYD2 \cdot \frac{d}{dt}P2$$

$$AREA = \frac{\pi}{4} \cdot (DIA1^2 - DIA2^2)$$

$$CHYD1 = \frac{VOL0_1 + \Delta S \cdot AREA}{B}$$

$$CHYD2 = \frac{VOL0_2 + (STROKE - \Delta S) \cdot AREA}{B}$$

$$M \cdot ACC = AREA(P(H1) - P(H2)) + FFRC + F(TRB1)$$

$$FFRC = \text{sgn}(v) \cdot \left((FSTK - FCLB) \cdot e^{-\frac{|V|}{K}} + FCLB + KVSC \cdot |V| \right)$$

Friction: Stick Coulomb Viscous

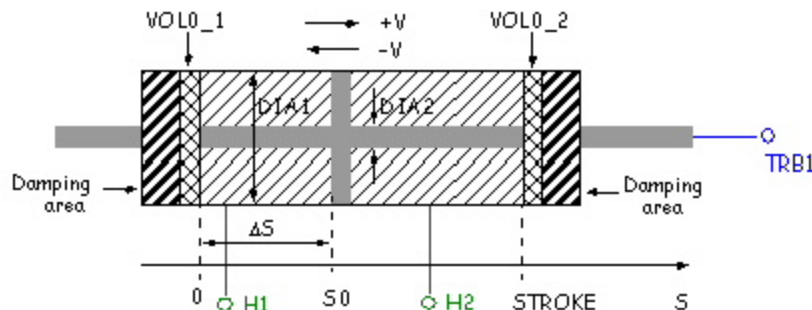

Figure 2 . Structure of the Equal Movement Cylinder

[Top](#)

Netlist Syntax

```
MODEL DOUBLE_CYL ?InstanceName(@InstanceName):(@ (Refbase)@ (ID)) H1:= %0,
TRB1:= %1, H2:= %2 ( S0:= @S0, STROKE:= @STROKE, M:= @M, B:= @B, VOL0_1:=
```

@VOL0_1, DAMPING:= @DAMPING, VOL0_2:= @VOL0_2, DIA1:= @DIA1, DIA2:= @DIA2, KVSC:= @KVSC, C:= @C, V0:= @V0, FCLB:= @FCLB, FSTK:= @FSTK, K:= @K) SRC: DB (Lib:=@ModelLibraryName);

[Top](#)

Conservative Pins

Table 1

Name	Port/Terminal description	Nature/Data type
H1	Fluidic Pin	Fluidic terminal
H2	Fluidic Pin	Fluidic terminal
TRB1	Translational Mechanical Pin	Mechanical terminal

[Top](#)

Parameters

Table 2

Name	Description	Data Type	Default Value [Unit]
DIA1	Piston Diameter	real	50m [m]
DIA2	Piston Rod Diameter	real	10m [m]
STROKE	Piston Stroke	real	0.1 [m]
M	Piston Mass	real	1 [kg]
KVSC	Viscous Friction Coefficient	real	0.1k [N s/m]
K	Slop Coefficient	real	1 [m/s]
FSTK	Slip Friction Force	real	0 [N]
FCLB	Coulomb Friction Force	real	0 [N]
VOL0_1	Initial Volume at H1	real	0 [m ³]
VOL0_2	Initial Volume at H2	real	0 [m ³]
B	Bulk Modulus	real	1G [Pa]
C	Spring Rate (Limit)	real	1Meg [N/m]
DAMPING	Damping Coefficient (Limit)	real	1Meg [N s/m]
S0	Initial Position	real	0 [m]
V0	Initial Velocity	real	0 [m/s]

[Top](#)

Input/Output Quantities

Table 3

Name	Description [Unit]	Direction	Data Type
S	Position [m]	Output	real
V	Velocity [m/s]	Output	real
ACC	Acceleration [m/s ²]	Output	real
FFRC	Friction Force [N]	Output	real

[Top](#)

Example

See example under [Double-Acting Actuator](#)

[Top](#)

References

See *Limit Stop* in the Basic Elements Library help.

Single-Acting Actuator

Library: Hydraulic	Modeling Language: SML	Version Number: Twin Builder 2024.2
--------------------	------------------------	-------------------------------------

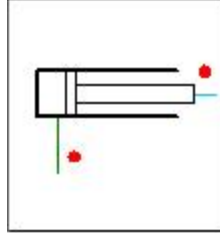

Figure 1 . Component symbol

- [Description](#)
- [Assumptions and Limitations](#)
- [Mathematical Description](#)
- [Netlist Syntax](#)
- [Conservative Pins](#)
- [Parameters](#)
- [Input/Output Quantities](#)
- [Example](#)
- [References](#)

Description

The model represents a Single-Acting Actuator with limit and stick-slip characteristic. The model applies fluid power in one direction. To move the piston back into the cylinder a mechanical force can be applied. This forces the fluid back to the reservoir.

The single-acting actuator is often used in the hydraulic jack. The elevators, which are used to move aircraft to and from the flight deck and hangar deck on aircraft carriers, also use cylinders of this type.

The multidomain model has one fluid port to apply the fluid power and one translational port to apply the mechanical force. The translational displacement-force representation of the mechanical domain is used.

[Top](#)

Assumptions and Limitations

The model is based on the following assumptions:

- Leakage, internal or external, is not taken into account.

- Loading on piston rod, such as inertia, friction, spring, and so on, is taken into account.

[Top](#)

Mathematical Description

The model calculating the damping area is identical to the Limit Stop model in the Basics library. The upper limit corresponds with the STROKE value, the lower limit is equal to S=0.

$$M \cdot ACC = P \cdot AREA - FFRC + F(TRB1)$$

$$FFRC = \text{sgn}(v) \cdot \left((FSTK - FCLB) \cdot e^{-\frac{|V|}{K}} + FCLB + KVSC \cdot |V| \right)$$

Friction: Stick Coulomb Viscous

$$Q = V \cdot AREA + CHYD \cdot \frac{dP}{dt}$$

$$AREA = \frac{\pi}{4} \cdot DIA^2$$

$$CHYD = \frac{(VOL0 + \Delta S \cdot AREA)}{B}$$

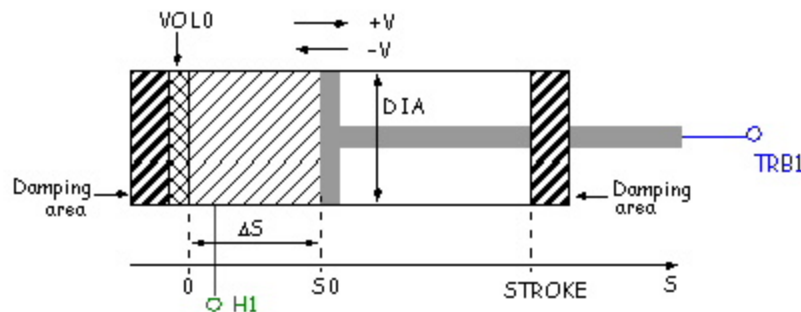

Figure 2 . Structure of the Single-Acting Actuator

[Top](#)

Netlist Syntax

```
MODEL SINGLE_ACT ?InstanceName(@InstanceName):(@ (Refbase)@ (ID)) H1:= %0,
TRB1:= %1 ( STROKE:= @STROKE, M:= @M, DIA:= @DIA, B:= @B, VOL0:= @VOL0,
DAMPING:= @DAMPING, C:= @C, KVSC:= @KVSC, V0:= @V0, S0:= @S0, FCLB:= @FCLB,
FSTK:= @FSTK, K:= @K) SRC: DB(Lib:=@ModelLibraryName);
```

[Top](#)

Conservative Pins

Table 1

Name	Port/Terminal description	Nature/Data type
H1	Fluidic Pin	Fluidic terminal
TRB1	Translational Mechanical Pin	Mechanical terminal

[Top](#)

Parameters

Table 2

Name	Description	Data Type	Default Value [Unit]
DIA	Piston Diameter	real	10m [m]
STROKE	Piston Stroke	real	0.1 [m]
M	Piston Mass	real	1m [kg]
KVSC	Viscous Friction Coefficient	real	0 [N s/m]
K	Slop Coefficient	real	1 [m/s]
FSTK	Slip Friction Force	real	0 [N]
FCLB	Coulomb Friction Force	real	0 [N]
VOL0	Initial Volume	real	1u [m ³]
B	Bulk Modulus	real	1G [Pa]
C	Spring Rate (Limit)	real	1Meg [N/m]
DAMPING	Damping Coefficient (Limit)	real	1Meg [N s/m]
S0	Initial Position	real	0 [m]
V0	Initial Velocity	real	0 [m/s]

[Top](#)

Input/Output Quantities

Table 3

Name	Description [Unit]	Direction	Data Type
S	Position [m]	Output	real

V	Velocity [m/s]	Output	real
ACC	Acceleration [m/s ²]	Output	real
FFRC	Friction Force [N]	Output	real

[Top](#)

Example

See example under [Double-Acting Actuator](#)

[Top](#)

References

See *Limit Stop* in the Basic Elements Library help.

Measurement

Fluidic meters provide pressure (Across quantity), flow rate (Through quantity), and power for fluidic domain components. The flow meter symbol shows the direction of the flow rate with an arrow (animated symbol function). The one pin manometer provides the differential pressure between the pin and the fluidic reference ground.

- [Manometer \(PM\)](#)
- [Manometer 1-Pin \(PM_R1\)](#)
- [Flowmeter \(QM\)](#)
- [Wattmeter \(WM_HYD\)](#)

Manometer

See *Fluidic Meters* in the Basic Elements Library help.

Manometer (1Pin)

Library: Hydraulic	Modeling Language: SML	Version Number: Twin Builder 2024.2
--------------------	------------------------	-------------------------------------

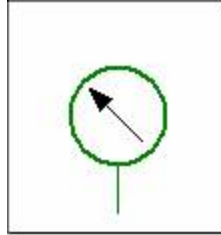

Figure 1 . Component symbol

- [Description](#)
- [Assumptions and Limitations](#)
- [Mathematical Description](#)
- [Netlist Syntax](#)
- [Conservative Pins](#)
- [Input/Output Quantities](#)
- [Example](#)
- [References](#)

Description

The Manometer represents a model with 1 pin. A laminar orifice ($K=1E-20 \text{ m}^3/(\text{s}*\text{Pa})$) is connected in parallel to ensure numeric stability.

The differential pressure is measured between the pin H1 and the fluidic reference ground.

[Top](#)

Assumptions and Limitations

The model is based on the following assumptions:

- Leakage, internal or external, is not taken into account.

[Top](#)

Mathematical Description

The structure of the Manometer model is shown in Figure 2, and its mathematical representation is:

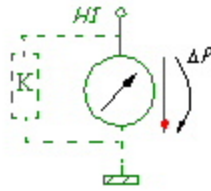

Figure 2. Equivalent structure of the Manometer model

$$q(t) = K \cdot p(t)$$

$$K = 10^{-20} \left[\frac{\text{m}^3}{\text{s} \cdot \text{Pa}} \right]$$

[Top](#)

Netlist Syntax

```
MODEL PM_R1 ?InstanceName(@InstanceName):(@ (Refbase)@ (ID)) H1:= %0 ( ) SRC: DB
(Lib:=@ModelLibraryName) ;
```

[Top](#)

Conservative Pins

Table 1

Name	Port/Terminal description	Nature/Data type
H1	Fluidic Pin	Fluidic terminal

[Top](#)

Input/Output Quantities

Table 2

Name	Description	Data type
P	Differential Pressure [Pa]	real

[Top](#)

Example

In this example the hydraulic capacitor is charged by an ideal pressure source through a laminar orifice. The time constant of the system is 1ms. The schematic of the example is shown in Figure 3, system parameters listed in Table 4 and the simulation results are shown in Figure 4.

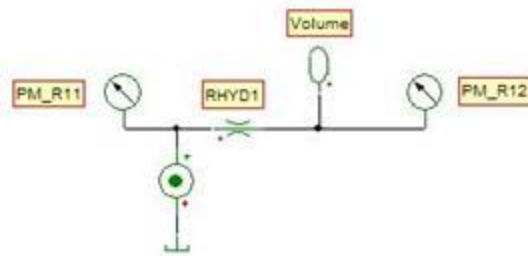

Figure 3. Application example of the Manometer model(1 pin)

Table 3. System Parameters

Component	Parameter	Value [unit]
Pressure Source P1	Value	1Meg [Pa]
Linear Orifice RHYD1	CONDUCTANCE	1n [m ³ /s*Pa ^{0.5}]
Hydraulic Capacitance Volume	VOL	1m [m ³]
	B	1G [Pa]
	P0	0 [Pa]

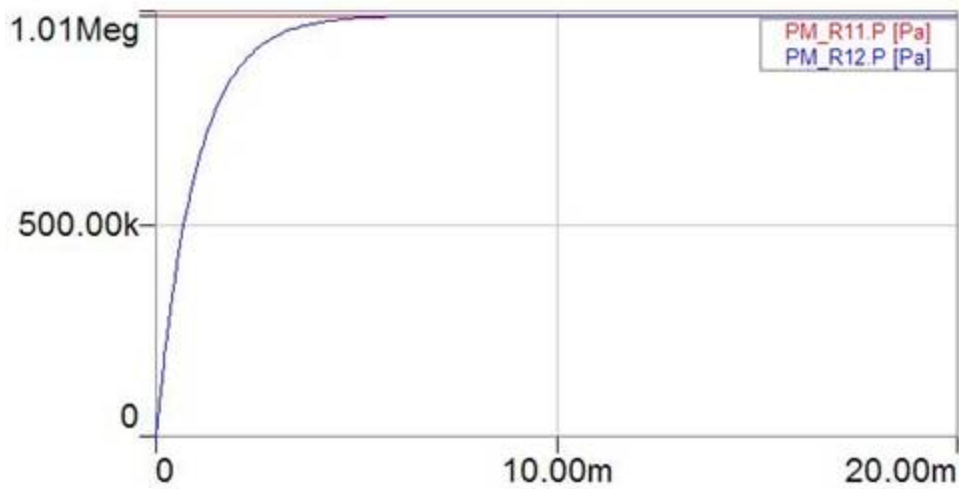

Figure 4. Simulation results

[Top](#)

References

Flowmeter

See *Fluidic Meters* in the Basic Elements Library help.

Wattmeter

See *Fluidic Meters* in the Basic Elements Library help.

Orifices

A orifice is a fluid resistance whose length is relatively short compared to its diameter or its cross-sectional dimension.

The hydraulic library provides orifices with several cross-section areas and characteristics.

- [Annular Orifice \(OR_ANN\)](#)
- [Sharp-Edge Orifice \(OR_SE\)](#)
- [Turbulent Orifice \(OR_TURB\)](#)
- [Variable Orifice \(OR_VAR\)](#)
- [Laminar Orifice \(RHYD\)](#)
- [Characteristic Orifice \(RHYD_NL\)](#)

Annular Orifice

Library: Hydraulic	Modeling Language: SML	Version Number: Twin Builder 2024.2
--------------------	------------------------	-------------------------------------

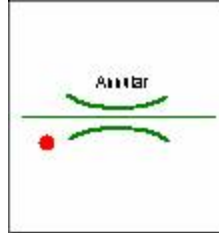

Figure 1. Component symbol

- [Description](#)
- [Assumptions and Limitations](#)
- [Mathematical Description](#)
- [Netlist Syntax](#)
- [Conservative Pins](#)
- [Parameters](#)
- [Input/Output Quantities](#)
- [Example](#)
- [References](#)

Description

The Annular Orifice represents a fluid resistance with laminar leakage between close fits.

The characteristics are based on flow through a close fitting cylindrical fit. This flow is analogous to flow between infinitely long parallel plates where the gap is small compared to the length or width. The flow for this case is assumed to always be laminar.

In translating, this characteristic to close fitting cylindrical fits care must be taken when selecting the parameters, or generics for the model. The analogy equates the flat plate-type width to the circumference of the cylindrical parts, and the length to the length of the cylindrical fit. The laminar flow equation used is only valid if the clearance of the fit is very small as compared to both the length and circumference. Rule of thumb, the radial clearance should be less than 1/10 of both the length and circumference.

The eccentricity is also accounted for in this model, with the effect of increasing the flow by 2.5 times when full eccentricity is specified, (eccentricity = 1.0), as compared to the fully concentric case (eccentricity = 0.0).

[Top](#)

Assumptions and Limitations

The model is based on the following assumptions:

- Fluid inertia is not taken into consideration.
- The fluidic flow is assumed to be laminar.

[Top](#)

Mathematical Description

The characteristics are described by the following equation, and the cross-sectional area of the orifice with different eccentricity is shown in Figure 2.

$$Q = P \cdot \pi \cdot \frac{DIA \cdot CLEAR_R^3}{12 \cdot VSC \cdot LEN} \cdot \left(1 + \frac{3}{2} \cdot ECC^2 \right)$$

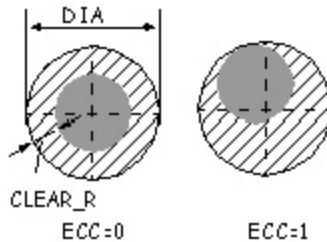

Figure 2. Cross sectional area of the orifice with different eccentricity

[Top](#)

Netlist Syntax

```
UMODEL OR_ANN ?InstanceName(@InstanceName):(@ (Refbase)@(ID)) H1:= %0, H2:= %1 (
DIA:= @DIA, LEN:= @LEN, CLEAR_R:= @CLEAR_R, ECC:= @ECC, VSC:= @VSC) SRC: DB
(Lib:=@ModelLibraryName);
```

[Top](#)

Conservative Pins

Table 1

Name	Port/Terminal description	Nature/Data type
H1	Fluidic Pin	Fluidic terminal
H2	Fluidic Pin	Fluidic terminal

[Top](#)

Parameters

Table 2

Name	Description	Data Type	Default Value [Unit]
DIA	Piston Diameter	real	1m [m]
LEN	Length	real	10m [m]
CLEAR_R	Radical Clearance	real	0.1m [m]
ECC	Eccentricity	real	0
VSC	Absolute Viscosity	real	1 [Pa s]

[Top](#)

Input/Output Quantities

Table 3

Name	Description	Data type
P	Differential Pressure [Pa]	real
Q	Flow Rate [m ³ /s]	real

[Top](#)

Example

In this example, a constant pressure develops a constant flow through the annular orifice. After 0.5 second, the eccentricity of the orifice changes from 0 to 1, which causes the change of the flow rate by a factor of 2.5. The schematic of the example is shown in Figure 3, system parameters listed in Table 4 and the simulation results are shown in Figure 4.

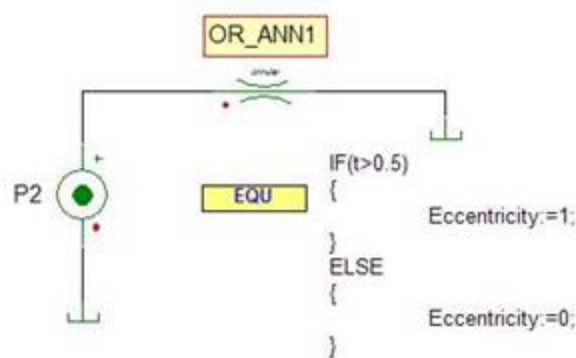

Figure 3. Application example of the Annular Orifice

Table 4. System Parameters

Component	Parameter	Value [unit]
-----------	-----------	--------------

Pressure Source P1	Value	1Meg [Pa]
Annular Orifice OR_ANN1	DIA	10 [m]
	LEN	0.5 [m]
	CLEAR_R	1m [m]
	ECC	Eccentricity
	VSC	10m [Pa s]

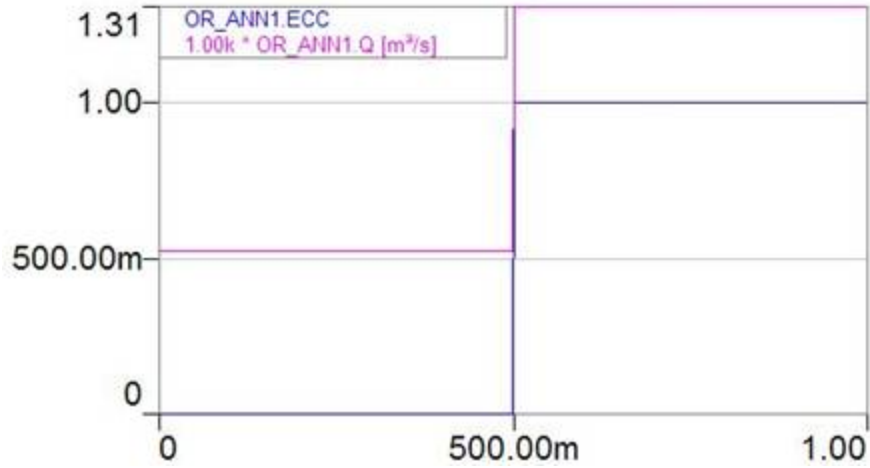

Figure 4. Simulation results

[Top](#)

References

Sharp-Edge Orifice

Library: Hydraulic	Modeling Language: SML	Version Number: Twin Builder 2024.2
--------------------	------------------------	-------------------------------------

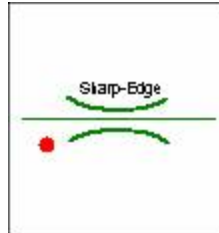

Figure 1 . Component symbol

- [Description](#)
- [Assumptions and Limitations](#)
- [Mathematical Description](#)
- [Netlist Syntax](#)
- [Conservative Pins](#)
- [Parameters](#)
- [Input/Output Quantities](#)
- [Example](#)
- [References](#)

Description

The Sharp-Edge Orifice represents a fluid resistance with laminar and turbulent flow depending on the selected type.

The characteristics are based on equations for laminar and turbulent flow through a sharp-edge orifice. The model uses generic shape parameters, as opposed to shape-specific dimensions so that it can be used as a building block for many other orifice models. Within the dialog you can select a generic, round, rectangular, or pintle type.



Figure 2. Different cross-sectional shapes of the Sharp-Edge Orifice

[Top](#)

Assumptions and Limitations

The model is based on the following assumptions:

- Fluid inertia is not taken into consideration.
- The transition between laminar and turbulent regimes is assumed to be sharp and taking place exactly when the Reynolds numbers reaches the critical value, *i.e.* $REY = REY_TRANS$.

[Top](#)

Mathematical Description

The equations used for the model characteristics change as the flow changes from laminar to turbulent flow, and care is taken to ensure continuity at the transition(s).

$$Q = CD(REY) \cdot AREA(TYPE) \cdot \sqrt{\frac{2 \cdot P}{RHO}}$$

$$REY = \frac{abs(Q) \cdot DIA(Hyd) \cdot RHO}{Area(TYPE) \cdot VSC}$$

$$REY < REY_TRANS$$

$$\text{Laminar Flow } CD(REY) = CD * \sqrt{\frac{REY}{REY_TRANS}}$$

$$REY \geq REY_TRANS$$

$$\text{Turbulent Flow } CD(REY) = CD$$

$$DIA(Hyd) = \frac{4 \cdot Area(Type)}{Peri(Type)}$$

Generic $Area = AREA$

$Peri = PERI$

Round $Area = \frac{\pi}{4} \cdot DIA^2$

$Peri = \pi \cdot DIA$

Rectangular $Area = LEN \cdot WIDTH$

$Peri = 2 \cdot (LEN + WIDTH)$

Pintle $Area = \frac{\pi}{4} \cdot (DIA_OUT^2 - DIA_IN^2)$

$Peri = (DIA_OUT + DIA_IN)$

[Top](#)

Netlist Syntax

Netlist generated by [Special Component Dialog](#).

[Top](#)

Conservative Pins

Table 1

Name	Port/Terminal description	Nature/Data type
H1	Fluidic Pin	Fluidic terminal
H2	Fluidic Pin	Fluidic terminal

[Top](#)

Parameters

Table 2

Name	Description	Data Type	Default Value [Unit]
AREA	Flow Area	real	1u [m ²]
CD	Discharge Coefficient	real	0.6
PERI	Perimeter	real	3m [m]
REY_TRANS	Reynolds Number (Transition)	real	300
RHO	Fluid Density	real	1K [kg/m ³]
VSC	Absolute Viscosity	real	10m [Pa s]
DIA	Diameter	real	1m [m]

[Top](#)

Input/Output Quantities

Table 3

Name	Description	Data type
P	Differential Pressure [Pa]	real
Q	Flow Rate [m ³ /s]	real
REY	Reynolds Number	real
ST_LAMINAR	Laminar State	real
ST_TURBULENT	Turbulent State	real

[Top](#)

Example

In this example, the output pressure from Pressure Source P1 increases linear with simulation time. The rising pressure causes the behavior of the Sharp-Edge Orifice OR_SE1 to switch from laminar to turbulent flow when the Reynolds number reaches the transition Reynolds. The schematic of the system is shown in Figure 3, system parameters are listed in Table 4, and the simulation results are shown in Figure 4.

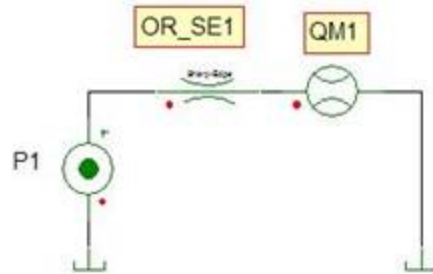

Figure 3. Application example of the Sharp-Edge Orifice

Table 4. System Parameters

Component	Parameter	Value [unit]
Pressure Source P1	Value	10Meg*t [Pa]
Sharp-Edged Orifice OR_SE1	Type	Round
	CD	0.6 [m]
	PERI	1m [m]
	REY_TRANS	3K
	RHO	1K [kg/m ³]
	VSC	10m [Pa s]
	DIA	1m [m]

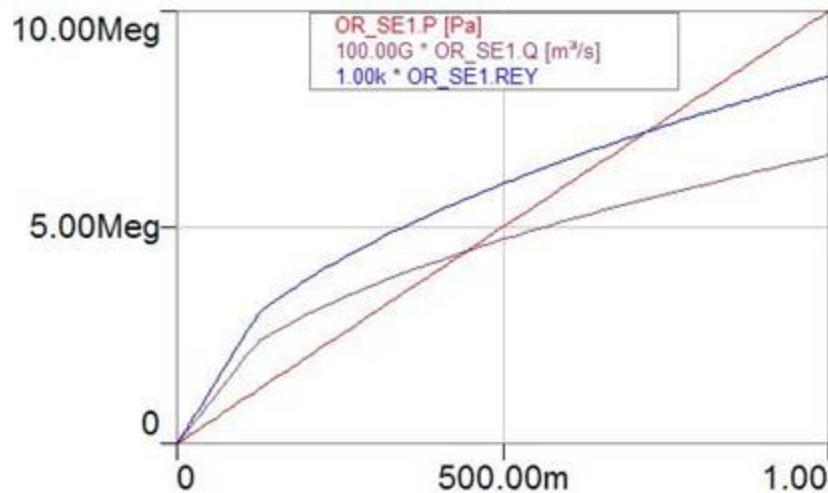

Figure 4. Simulation results

[Top](#)

References

Turbulent Orifice

Library: Hydraulic

Modeling Language: SML

Version Number: Twin Builder 2024.2

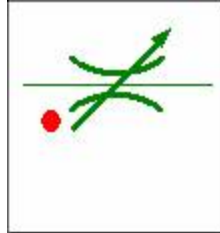

Figure 1 . Component symbol

- [Description](#)
- [Assumptions and Limitations](#)
- [Mathematical Description](#)
- [Netlist Syntax](#)
- [Conservative Pins](#)
- [Parameters](#)
- [Input/Output Quantities](#)
- [Example](#)
- [References](#)

Description

The Turbulent Orifice represents a fluid resistance with turbulent flow (non-linear flow characteristic curve) if no cavitation occurs. A shape which is designed with sudden changes of cross-section means that there is turbulent flow even at low flow speeds, so that the flow is largely viscosity-independent and thus temperature-independent. The conductance K describes the flow for high Reynolds numbers.

The Turbulent Orifice is used for speed setting of loads, or as a decoupling element to feed multiple loads from a constant pressure source.

[Top](#)

Assumptions and Limitations

The model is based on the following assumptions:

- Fluid inertia is not taken into account.

[Top](#)

Mathematical Description

$$Q = K \cdot \sqrt{P}$$

[Top](#)

Netlist Syntax

```
UMODEL OR_TURB ?InstanceName(@InstanceName):(@ (Refbase)@(ID)) H1:= %0, H2:= %1 ( K:= @K) SRC: DB(Lib:=@ModelLibraryName) ;
```

[Top](#)

Conservative Pins

Table 1

Name	Port/Terminal description	Nature/Data type
H1	Fluidic Pin	Fluidic terminal
H2	Fluidic Pin	Fluidic terminal

[Top](#)

Parameters

Table 2

Name	Description	Data Type	Default Value [Unit]
K	Conductance	real	0.1u [m ³ /(s*Pa ^{0.5})]

[Top](#)

Input/Output Quantities

Table 3

Name	Description	Data type
P	Differential Pressure [Pa]	real
Q	Flow Rate [m ³ /s]	real

[Top](#)

Example

This example demonstrates that a rising flow rate causes a nonlinear pressure drop in the turbulent orifice. The schematic of the example is shown in Figure 2, system parameters listed in Table 4 and the simulation results are shown in Figure 3.

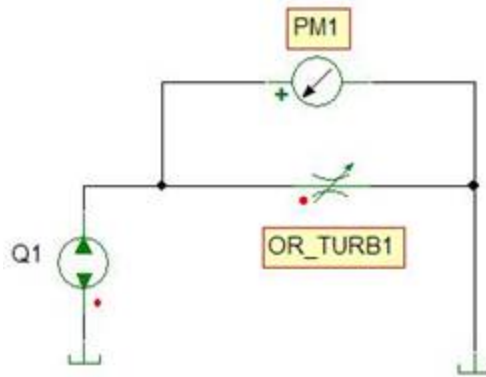

Figure 2. Application example of the Turbulent Orifice Model

Table 4. System Parameters

Component	Parameter	Value [unit]
Flow Source Q1	Value	$100u^*t$ [m ³ /s]
Turbulent Orifice OR_TURB1	CONDUCTANCE	$3e-7$ [m ³ /s*Pa ^{0.5}]

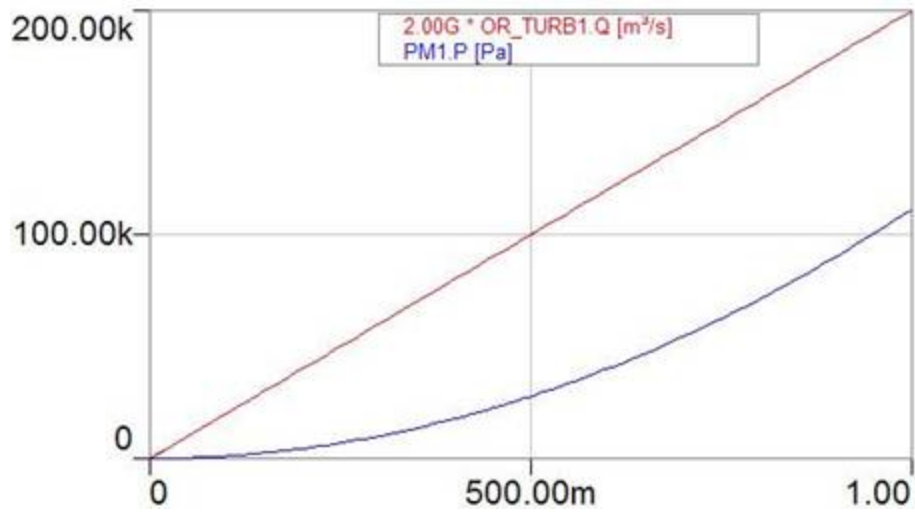

Figure 3. Simulation results

[Top](#)

References

Variable Orifice

Library: Hydraulic	Modeling Language: SML	Version Number: Twin Builder 2024.2
--------------------	------------------------	-------------------------------------



Figure 1. Component symbol

- [Description](#)
- [Assumptions and Limitations](#)
- [Mathematical Description](#)
- [Netlist Syntax](#)
- [Conservative Pins](#)
- [Parameters](#)
- [Input/Output Quantities](#)
- [Example](#)
- [References](#)

Description

The Variable Orifice represents a variable fluid resistance. The characteristics are based on equations for laminar and turbulent flow through a sharp-edge orifice, and allows the flow area to vary as a function of the relative positions of the translational connections. This model uses linear shape parameters to facilitate modeling of spool-type valves where the spool opens a rectangular slot. This slot can be any width and length, the dimensions of which are determined by the Parameters for maximum flow area and displacement of the mechanical connections for the closed and full open points.

[Top](#)

Assumptions and Limitations

The model is based on the following assumptions:

- Fluid inertia is not taken into consideration.
- The transition between laminar and turbulent regimes is assumed to be sharp and taking place exactly when the Reynolds numbers reaches the critical value, *i.e.* $REY = REY_TRANS$.

[Top](#)

Mathematical Description

The equations used for the model characteristics change as the flow changes from laminar to turbulent flow, and care is taken to ensure continuity at the transition(s).

There are no pressure-induced forces calculated in this model. The only forces modeled are those due to steady state flows. This flow force is calculated based on equations for typical steady state momentum based reactions. This flow force is multiplied by the value of FACT, which when set = 1.0 gives the force reaction calculated. The default for the factor is '0', so there is no flow force in default.

$$Q = CD(REY) \cdot AREA(TYPE) \cdot \sqrt{\frac{2 \cdot P}{RHO}}$$

$$REY = \frac{abs(Q) \cdot DIA(PERI) \cdot RHO}{AREA(TYPE) \cdot VSC}$$

$$REY < REY_TRANS$$

$$\text{Laminar Flow } CD(REY) = CD * \sqrt{\frac{REY}{REY_TRANS}}$$

$$REY \geq REY_TRANS$$

$$\text{Turbulent Flow } CD(REY) = CD$$

$$F = FACT \cdot POLARITY \cdot 2 \cdot CD \cdot CV \cdot AREA \cdot \cos\left(69 \cdot \frac{\pi}{180}\right) \cdot P \quad CV = 0.98$$

There are three types of areas defined in this model:

- Linear Type

In this case, the flow area depends on the actual displacement(s).

$$AREA_MIN \leq AREA \leq AREA_MAX;$$

$$\text{If } s \leq S_MIN \text{ then } AREA = AREA_MIN;$$

$$\text{If } s \geq S_MAX \text{ then } AREA = AREA_MAX$$

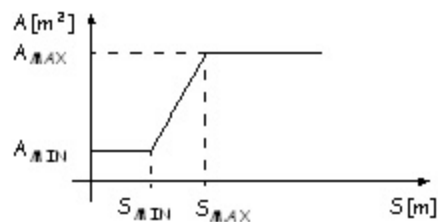

Figure 2. The relation between the Flow Area (Area) and the Displacement (s) for Variable Orifice model with linear area

- Ball-Seat Type
- Poppet Type

[Top](#)

Netlist Syntax

Netlist generated by [Special Component Dialog](#).

[Top](#)

Conservative Pins

Table 1

Name	Port/Terminal description	Nature/Data type
H1	Fluidic Pin	Fluidic terminal
H2	Fluidic Pin	Fluidic terminal
TRB1	Translational Mechanical Pin	Mechanical terminal
TRB2	Translational Mechanical Pin	Mechanical terminal

[Top](#)

Parameters

Table 2

Name	Description	Data Type	Default Value [Unit]
CD	Discharge Coefficient	real	0.6
FACT	Flow Force Factor	real	0
REY_TRANS	Reynolds Number (Transition)	real	10
RHO	Fluid Density	real	1k [kg/m ³]
VSC	Absolute Viscosity	real	10m [Pa s]
S_MAX	Relative Displacement for Maximum Area of Linear Type	real	1m [m]
S_MIN	Relative Position for Minimum Opening	real	0 [m]
AREA_MAX	Maximum Flow Area of Linear Type	real	1E-6 [m ²]

AREA_MIN	Minimum Flow Area of Linear Type	real	1E-9 [m ²]
DIA	Diameter	real	1m [m]
POLARITY	Polarity for Open Direction of Ball-Seat and Poppet Type	real	1
PHI	Seat Included Angle of Ball-Seat and Poppet Type	real	MATH_PI/2 [rad]
OPEN_MIN	Minimum Opening of Ball-Seat and Poppet Type	real	1n [m]

[Top](#)

Input/Output Quantities

Table 3

Name	Description	Data type
P	Differential Pressure [Pa]	real
Q	Flow Rate [m ³ /s]	real
S	Displacement [m]	real
F	Force [N]	real
REY	Reynolds Number	real
AREA	Flow Area [m ²]	real
DIA_HYD	Hydraulic Diameter [m ²]	real
PERI	Perimeter [m]	real
ST_LAMINAR	Laminar State	real
ST_TURBULENT	Turbulent State	real

[Top](#)

Example

In this example, the Pressure Source P2 provides a constant pressure level. The flow through the Variable Orifice OR_VAR1 is controlled by its variable flow area. The schematic of the system is shown in Figure 3, system parameters are listed in Table 4, and the simulation results are shown in Figure 4.

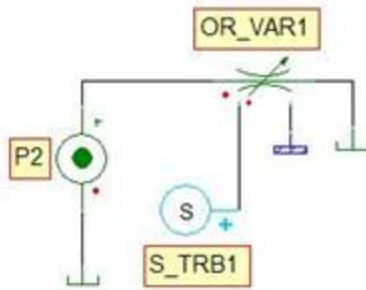

Figure 3. Application example of the Variable Orifice model

Table 4. System Parameters

Component	Parameter	Value [unit]
Pressure Source P2	Value	11.5Meg [Pa]
Variable Orifice OR_VAR1	Area Type	Linear
	CD	0.6
	FACT	1
	REY_TRANS	10
	RHO	1K [kg/m ³]
	VSC	10m [Pa s]
	S_MAX	1m [m]
	S_MIN	0 [m]
	AREA_MAX	1E-6 [m ²]
	AREA_MIN	1E-9 [m ²]

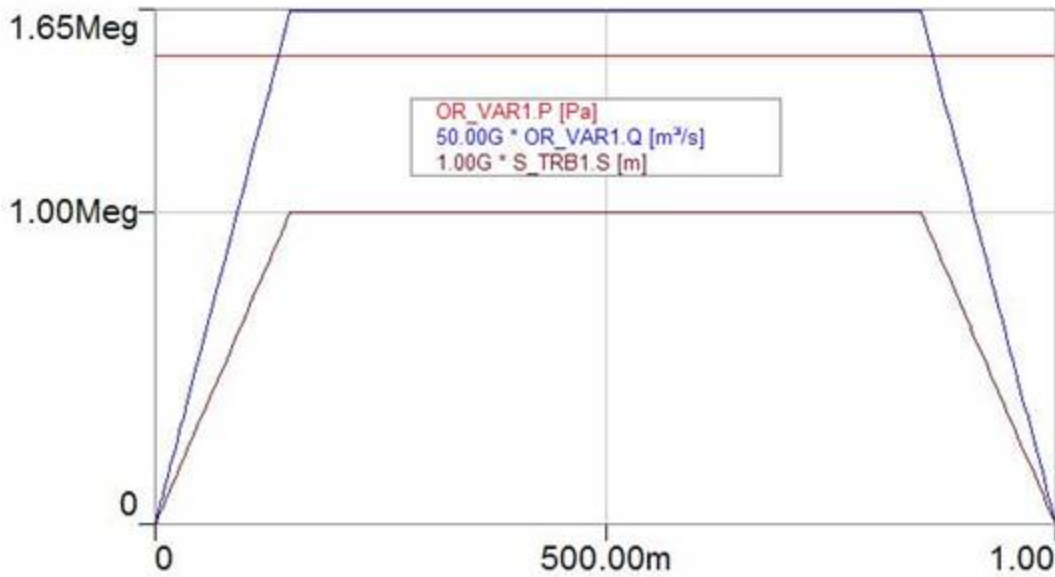

Figure 4. Simulation results

[Top](#)

References

[1] Fitch, E.C. and I.T. Hong. *Hydraulic Component Design and Selection*. BarDyne, Inc., 1997

Laminar Orifice

The Laminar Orifice represents a fluid resistance with laminar flow (linear flow characteristic curve). The conductance K describes the flow for very small Reynolds numbers. The Laminar Orifice is used for long lines, leakage in valves, hydrostatic slipper bearings, etc. The Laminar Orifice is the same model as Linear Orifice in the Basic Elements library.

See *Linear Orifice* in the Basic Elements Library help.

Characteristic Orifice

Library: Hydraulic	Modeling Language: SML	Version Number: Twin Builder 2024.2
--------------------	------------------------	-------------------------------------

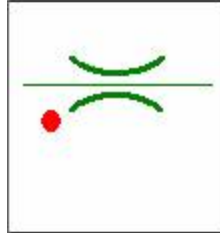

Figure 1. Component symbol

- [Description](#)
- [Assumptions and Limitations](#)
- [Mathematical Description](#)
- [Netlist Syntax](#)
- [Conservative Pins](#)
- [Parameters](#)
- [Input/Output Quantities](#)
- [Example](#)
- [References](#)

Description

The Characteristic Orifice represents a fluid resistance with a user-defined Q-P characteristic.

The last slope is effective for all values outside the X-range. If you want to have a constant value outside the X-range, you have to define two data-pairs with the same Y-value at the end.

[Top](#)

Assumptions and Limitations

[Top](#)

Mathematical Description

The fluid resistance of the Characteristic Orifice model is defined by a user-defined Q-P characteristic. Figure 2 shows the symmetrical and nonsymmetrical characteristics for both fluid flow directions.

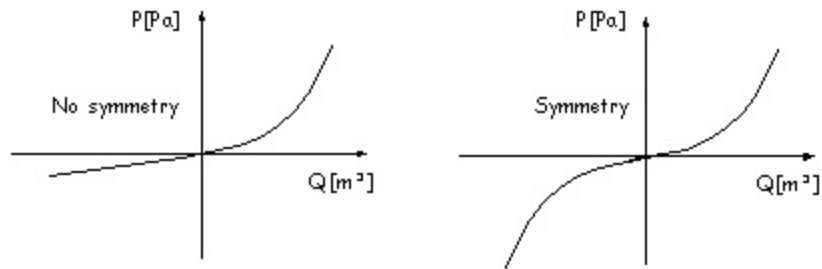

Figure 2. Symmetrical and non-symmetrical Q-P characteristics

[Top](#)

Netlist Syntax

Netlist generated by [Special Component Dialog](#).

[Top](#)

Conservative Pins

Table 1

Name	Port/Terminal description	Nature/Data type
H1	Fluidic Pin	Fluidic terminal
H2	Fluidic Pin	Fluidic terminal

[Top](#)

Parameters

Table 2

Name	Description	Data Type	Default Value [Unit]
CH	Characteristic $P=f(Q)$	real	n/a

[Top](#)

Input/Output Quantities

Table 3

Name	Description	Data type
P	Differential Pressure [Pa]	real

Q	Flow Rate [m ³ /s]	real
---	-------------------------------	------

[Top](#)

Example

[Top](#)

References

Passive Elements

- Volume (CHYD)
- Pipe (PIPE)
- Blind Plug (PLUG)

Volume

See *Hydraulic Capacitance* in the Basic Elements Library help.

Pipe

Library: Hydraulic	Modeling Language: SML	Version Number: Twin Builder 2024.2
--------------------	------------------------	-------------------------------------

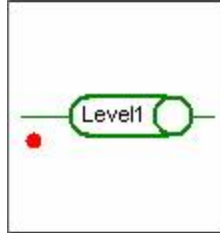

Figure 1. Component symbol

- [Description](#)
- [Assumptions and Limitations](#)
- [Mathematical Description](#)
- [Netlist Syntax](#)
- [Conservative Pins](#)
- [Parameters](#)
- [Input/Output Quantities](#)
- [Example](#)

Description

The Pipe represents a fluid resistance element that can include the effects of fluid inertia, or hydraulic inductance, as well as fluid compressibility, or hydraulic capacitance. The characteristics are based on equations for laminar and turbulent flow through a smooth round/rectangular pipe, and are supplemented with the differential equations for the effect of fluid mass and acceleration, and compressibility of the fluid volume.

[Top](#)

Assumptions and Limitations

[Top](#)

Mathematical Description

The Level 1 model calculates the laminar and turbulent flow through a smooth round/rectangular pipe. The following equations based on the Darcy-Weisbach equations are used:

$$P = \text{FACT_FRIC} \cdot \frac{\text{LEN}}{\text{DIA}} \cdot \frac{\text{RHO} \cdot V^2}{2} = P_VSC$$

$$V = \frac{Q}{\text{AREA}}$$

$$\text{REY} = \frac{|Q| \cdot \text{RHO} \cdot \text{DIA}}{\text{VSC} \cdot \text{AREA}}$$

The round pipe, the AREA is:

$$\text{AREA} = \frac{\pi}{4} \cdot \text{DIA}^2$$

For rectangular pipe, the AREA is:

$$\text{AREA} = \text{HEIGHT} \cdot \text{WIDTH} \quad \text{WIDTH} \geq \text{HEIGHT}$$

The Level 2 model calculates the flow characteristic and includes the effects of fluid compressibility, or hydraulic capacitance. The following equations based on both the Darcy-Weisbach equations and the fluid compressibility differential equation are used:

$$P = P_VSC$$

The fluid compressibility is modeled by dividing the volume of fluid in the pipe by 2 and placing each half volume at each end of the pipe. The flow into each of the volumes is governed by the following equation.

$$Q = \frac{\text{AREA} \cdot \text{LEN}}{B} \cdot \frac{dP}{dt}$$

The Level 3 model calculates the flow characteristic and includes the effects of fluid compressibility, or hydraulic capacitance, as well as fluid inertia, or hydraulic inductance. The following equations based on the Darcy-Weisbach equations, the inductive differential equation, and the capacitive differential equations are used:

$$P = P_VSC + P_IND$$

$$P_IND = \frac{\text{RHO} \cdot \text{LEN}}{\text{AREA}} \cdot \frac{dQ}{dt}$$

The flow characteristics include three separate regions described as follows:

- Laminar flow, where $\text{reynolds_number} < \text{reynolds_laminar}$

- Turbulent flow, where $reynolds_number > reynolds_turbulent$
- Transition flow, where the characteristic are interpolated between the laminar and turbulent, transition points, *i.e.* $reynolds_laminar \leq reynolds_number \leq reynolds_turbulent$

For the laminar flow region the friction factor, $friction_factor$, is calculated using the Hagen-Poiseuille law as follows:

$$FACT_FRIC = \frac{64}{REY}$$

For the turbulent flow region the friction factor, $friction_factor$, is calculated using the Blasius law as follows.

$$FACT_FRIC = \frac{0.316}{REY^{0.25}}$$

For the transition region the flow characteristics are obtained by interpolating between the laminar and turbulent transition points. There is also a relative smoothness factor that increases the characteristic pressure drop in proportion. For example, if the pipe can be described as having roughness on the surface that is double that of a smooth pipe, the factor would be set equal to 2.0.

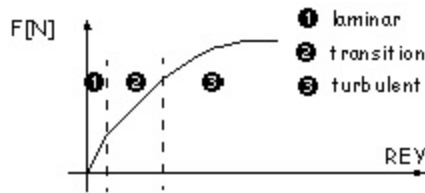

Figure 2. Relation between Fluid Force(F) and Reynolds Number (REY)

[Top](#)

Netlist Syntax

Netlist generated by [Special Component Dialog](#).

[Top](#)

Conservative Pins

Table 1

Name	Port/Terminal description	Nature/Data type
H1	Fluidic Pin	Fluidic terminal
H2	Fluidic Pin	Fluidic terminal

[Top](#)

Parameters

Table 2

Name	Description	Data Type	Default Value [Unit]
LEN	Length	real	1 [m]
DIA	Diameter of round pipe	real	10m [m]
HEIGHT	Height of the rectangular pipe	real	10u [m]
WIDTH	Width of the rectangular pipe	real	0.1m [m]
FACT	Flow Force Factor	real	1
REY_LAMINAR	Reynolds Number (laminar)	real	2k
REY_TURBULENT	Reynolds Number (Turbulent)	real	4k
RHO	Fluid Density	real	1k [kg/m ³]
VSC	Absolute Viscosity	real	10m [Pa s]
B	Bulk Modulus for Model Level 2 and 3	real	1G [Pa]

[Top](#)

Input/Output Quantities

Table 3

Name	Description	Data type
P	Differential Pressure [Pa]	real
Q	Flow Rate [m ³ /s]	real
REY	Reynolds Number	real
ST_LAMINAR	Laminar State	real
ST_TRANS	Transition State	real
ST_TURBULENT	Turbulent State	real

[Top](#)

Example

Reference:

[1] Keller, George. *Hydraulic System Analysis, Hydraulics and Pneumatics*, Second Edition, 1974.

Blind Plug

Library: Hydraulic	Modeling Language: SML	Version Number: Twin Builder 2024.2
--------------------	------------------------	-------------------------------------

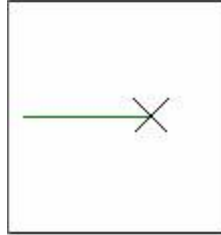

Figure 1. Component symbol

- [Description](#)
- [Assumptions and Limitations](#)
- [Netlist Syntax](#)
- [Conservative Pins](#)
- [Example](#)
- [References](#)

Description

The Blind Plug represents a blocked line connection. It consists of a laminar orifice with a conductance of $K=1E-20 \text{ m}^3/(\text{s}*\text{Pa})$, which is connected to ground level.

The Blind Plug is used for closing open pins (conservative nodes) on hydraulic components. Unused line connections on directional valves can be blocked.

[Top](#)

Assumptions and Limitations

The Blind Plug model is based on the following assumptions:

- No leakage, internal or external, is considered.

[Top](#)

Netlist Syntax

```
MODEL PLUG ?InstanceName(@InstanceName):(@ (Refbase)@(ID)) H1:= %0 ( ) SRC: DB  
(Lib:=@ModelLibraryName) ;
```

[Top](#)

Conservative Pins

Table 1

Name	Port/Terminal description	Nature/Data type
H1	Fluidic Pin	Fluidic terminal

[Top](#)

Example

In this example, a constant pressure causes a constant flow in the Laminar Orifice RHYD1. After 1s the valve switches and the pressure is then applied to RHYD2, resulting a flow there. The Blind Plug PLUG1 is used to close the open hydraulic pin at the valve. The schematic of the system is shown in Figure 2, system parameters are listed in Table 2, and the simulation results are shown in Figure 3.

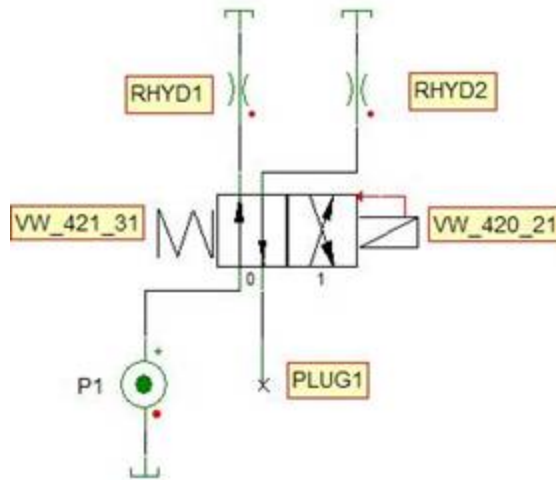

Figure 2. Application example of the Blind Plug model

Table 2. System Parameters

Component	Parameter	Value [unit]
Pressure Source P1	Value	11.5Meg [Pa]
RHYD1	K	1n [m ³ /(Pa s)]
RHYD3	K	3n [m ³ /(Pa s)]
Direction Control Valve (ON Function 3) VW_421_31	CTRL	t>1
Direction Control Valve (OFF Function	SET	VW_421_

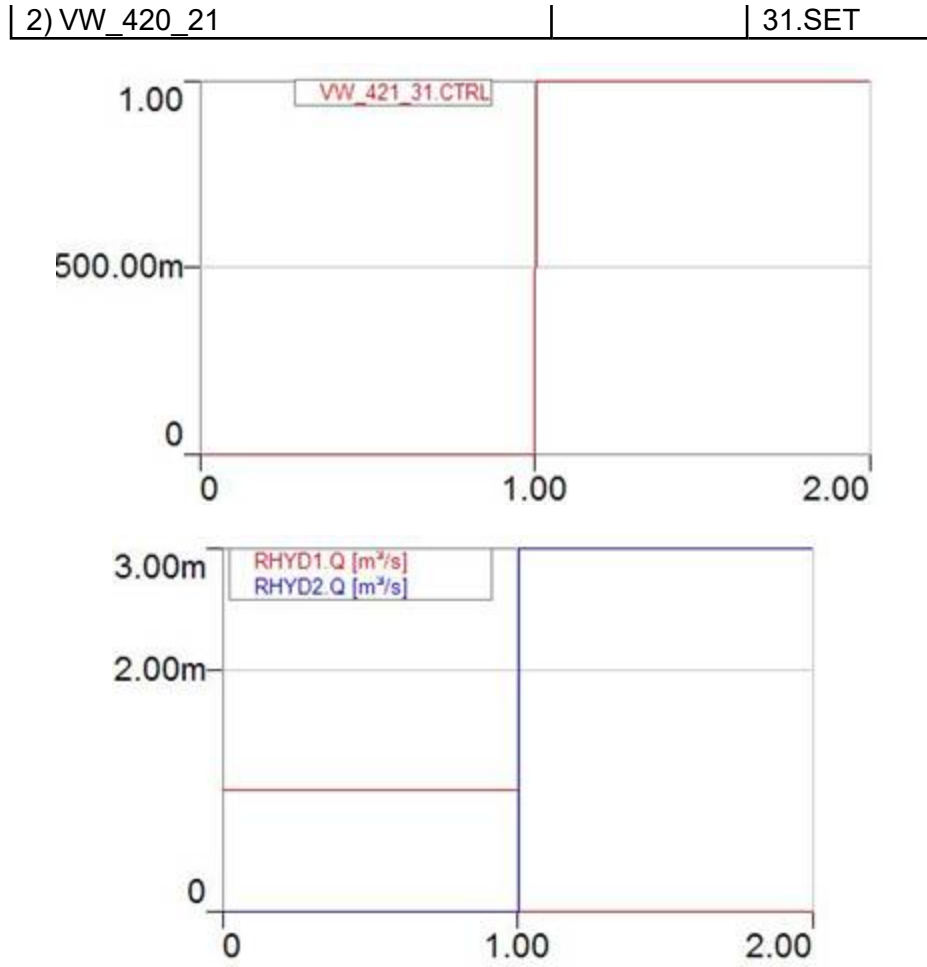

Figure 3. Simulation Results

[Top](#)

References

Hydraulic Sources

- [Pressure Source \(P\)](#)
- [Pump \(PUMP\)](#)
- [Flow Source \(Q\)](#)

Pressure Source

See *Pressure Source* in the Basic Elements Library help.

Pump

Library: Hydraulic	Modeling Language: SML	Version Number: Twin Builder 2024.2
--------------------	------------------------	-------------------------------------

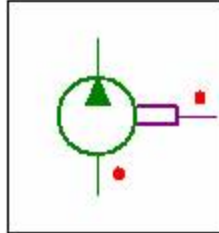

Figure 1. Component symbol

- [Description](#)
- [Assumptions and Limitations](#)
- [Mathematical Description](#)
- [Netlist Syntax](#)
- [Conservative Pins](#)
- [Parameters](#)
- [Input/Output Quantities](#)
- [Example](#)
- [References](#)

Description

The Pump represents an ideal flow source which supplies the defines flow rate, which depends on the geometrical displacement volume $VOLG$ and the angular velocity $OMEGA$ of the drive. The angular velocity is provided as an across quantity at the rotational pin $ROT1$.

[Top](#)

Assumptions and Limitations

[Top](#)

Mathematical Description

If $OMEGA < 0$ or if $P(H1) < -1E5$, an error message occurs. If $P > PUL$, a warning is displayed.

The flow and torque equations are shown as follows:

$$Q = \text{VOLG} \cdot \frac{\text{OMEGA}}{2\pi} \cdot \frac{\text{ETAV}}{100}$$

$$\text{ETAV} = f(P)$$

$$\text{TORQUE} = \text{VOLG} \cdot \frac{P}{2\pi}$$

[Top](#)

Netlist Syntax

[Top](#)

Conservative Pins

Table 1

Name	Port/Terminal description	Nature/Data type
H1	Fluidic Pin	Fluidic terminal
H2	Fluidic Pin	Fluidic terminal
ROT1	Rotational Mechanic Pin	Mechanic Terminal

[Top](#)

Parameters

Table 2

Name	Description	Data Type	Default Value [Unit]
VOLG	Volumetric Displacement	real	10u [m]
CH	Characteristic ETAV=f(P)	real	
PUL	Maximum Pressure, Maximum x-value of Characteristic	real	10Meg [Pa]
WIDTH	Width of the Rectangular Pipe	real	0.1m [m]

For more details about the parameters, see [Special Component Dialog..](#)

[Top](#)

Input/Output Quantities

Table 3

Name	Description	Data type
P	Differential Pressure [Pa]	real
Q	Flow Rate [m ³ /s]	real
OMEGA	Angular Velocity [[rad/s]]	real
TORQUE	Torque [Nm]	real
N	Rotational Speed [rpm]	real
ETAV	Volumetric Efficiency [%]	real

[Top](#)

Example

In this example, the angular velocity output from the Angular Velocity Source V_ROT1 increase with time. The increasing angular velocity causes an increasing flow in the Pump PUMP1. The flow is routed through the Directional Control Valve VW_32_31 to the Laminar Orifice RHYD1. After 1s, the valve switches and flow path changes to RHYD2. The difference in the slops of OMEGA and Flow Rate is due to the pressure dependency of the pump efficiency. The schematic of the system is shown in Figure 2, system parameters are listed in Table 4, and the simulation results are shown in Figure 3.

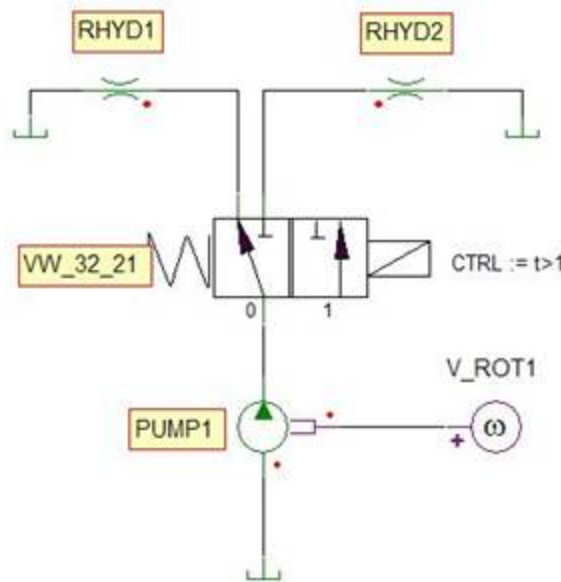
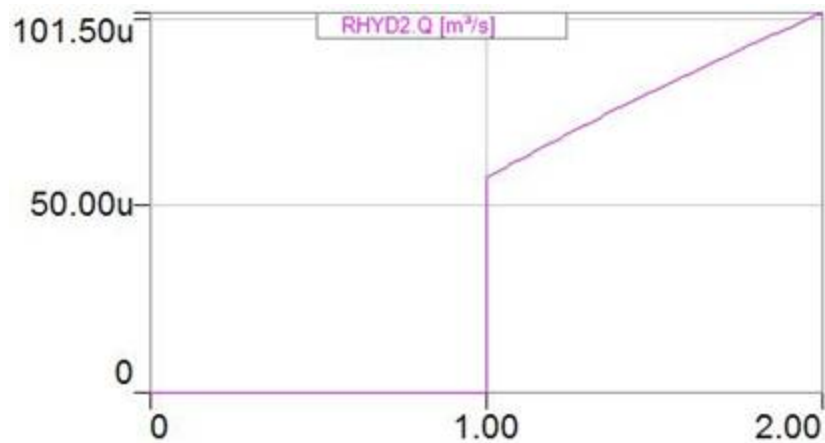
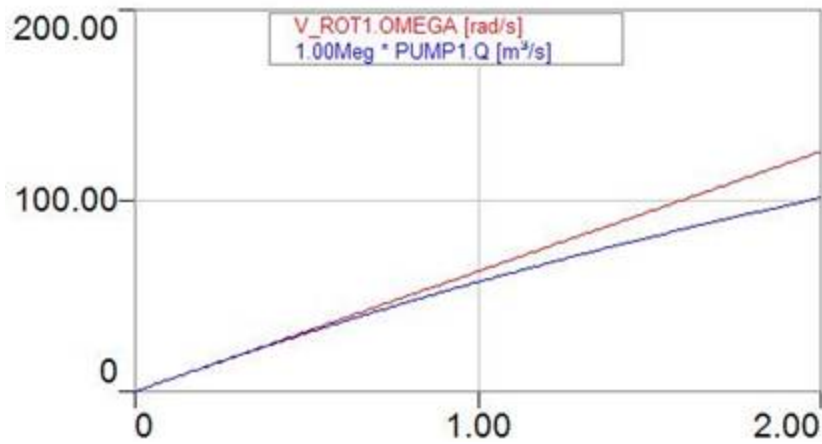

Figure 2. Application example of the Pump model

Table 4. System Parameters

Component	Parameter	Value [unit]
Pressure Source P1	Value	11.5Meg [Pa]
RHYD1	K	5e-12 [m ³ / (Pa s)]
RHYD2	K	5e-12 [m ³ / (Pa s)]
Direction Control Valve (ON Function 2) VW_321_21	CTRL	t>1
PUMP	VOLG	2*PI*1u
Angular Velocity Source	V_ROT1	2*PI*10*t



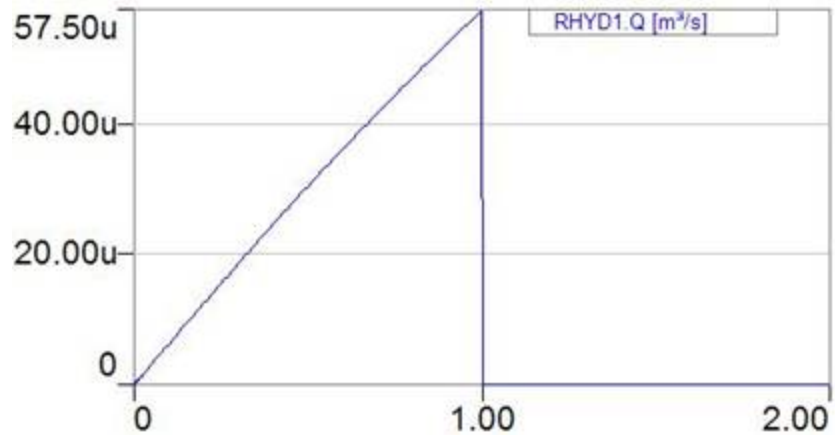

Figure 3. Simulation results

[Top](#)

References

Flow Source

See *Flow Source* in the Basic Elements Library help.

Hydraulic Switches

- Limit Switch 1 (LS1)
- Limit Switch 2 (LS2)
- Limit Switch 3 (LS3)
- Limit Switch 4 (LS4)
- Normally Closed (SC_HYD)
- Change Over (SCO_HYD)
- Normally Open (SO_HYD)
- Pressure Switch (SP_HYD)

Limit Switch 1

Library: Hydraulic	Modeling Language: SML	Version Number: Twin Builder 2024.2
--------------------	------------------------	-------------------------------------

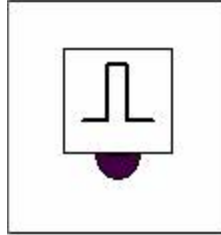

Figure 1. Component symbol

- [Description](#)
- [Assumptions and Limitations](#)
- [Mathematical Description](#)
- [Netlist Syntax](#)
- [Parameters](#)
- [Input/Output Quantities](#)
- [Example](#)
- [References](#)

Description

The model represents a limit switch. If the input signal INPUT crosses the threshold value THRES, the model returns the value '1' for a time of maximum time step HMAX, otherwise the model returns the value '0'. The switch return value (switch closed: 1, switch open: 0) is shown visually during the simulation with a red mark in the symbol.

[Top](#)

Assumptions and Limitations

[Top](#)

Mathematical Description

Limit switches are contact elements which are controlled by mechanical magnitudes (for example cylinder paths).

If $INPUT \geq THRESHOLD$, then $VAL = 1$ for a time of maximum time step HMAX.

Else $VAL = 0$.

[Top](#)

Netlist Syntax

```
MODEL LS1 ?InstanceName(@InstanceName):(@ (Rebase)@(ID)) ( THRES:= @THRES,  
INPUT:= @INPUT) SRC: DB(Lib:=@ModelLibraryName);
```

[Top](#)

Parameters

Table 1

Name	Description	Data Type	Default Value [Unit]
THRES	Threshold Value	real	0

[Top](#)

Input/Output Quantities

Table 2

Name	Description	Data type
INPUT	Input Signal	real
VAL	Return Value	real

[Top](#)

Example

[Top](#)

References

Limit Switch 2

Library: Hydraulic	Modeling Language: SML	Version Number: Twin Builder 2024.2
--------------------	------------------------	-------------------------------------

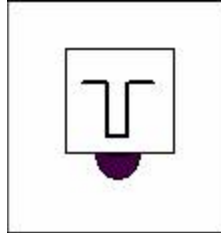

Figure 1. Component symbol

- [Description](#)
- [Assumptions and Limitations](#)
- [Mathematical Description](#)
- [Netlist Syntax](#)
- [Parameters](#)
- [Input/Output Quantities](#)
- [Example](#)
- [References](#)

Description

The model represents a limit switch. If the input signal INPUT crosses the threshold value THRES, the model returns the value '0' for a time of maximum time step HMAX, otherwise the model returns the value '1'. The switch return value (switch closed: 1, switch open: 0) is shown visually during the simulation with a red mark in the symbol.

[Top](#)

Assumptions and Limitations

[Top](#)

Mathematical Description

Limit switches are contact elements which are controlled by mechanical magnitudes (for example cylinder paths).

If $INPUT \geq THRESHOLD$, then $VAL = 0$ for a time of maximum time step HMAX.

Else $VAL = 1$.

[Top](#)

Netlist Syntax

```
MODEL LS2 ?InstanceName(@InstanceName):(@(Rebase)@(ID)) ( THRES:= @THRES,  
INPUT:= @INPUT) SRC: DB(Lib:=@ModelLibraryName);
```

[Top](#)

Parameters

Table 1

Name	Description	Data Type	Default Value [Unit]
THRES	Threshold Value	real	0

[Top](#)

Input/Output Quantities

Table 2

Name	Description	Data type
INPUT	Input Signal	real
VAL	Return Value	real

[Top](#)

Example

[Top](#)

References

Limit Switch 3

Library: Hydraulic	Modeling Language: SML	Version Number: Twin Builder 2024.2
--------------------	------------------------	-------------------------------------

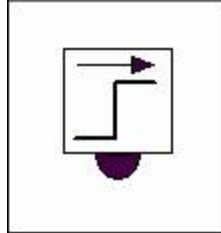

Figure 1. Component symbol

- [Description](#)
- [Assumptions and Limitations](#)
- [Mathematical Description](#)
- [Netlist Syntax](#)
- [Parameters](#)
- [Input/Output Quantities](#)
- [Example](#)
- [References](#)

Description

The model represents a limit switch. If the input signal INPUT is greater than the threshold value THRES, the model returns the value '1', otherwise the model returns the value '0'. The switch return value (switch closed: 1, switch open: 0) is shown visually during the simulation with a red mark in the symbol.

[Top](#)

Assumptions and Limitations

[Top](#)

Mathematical Description

Limit switches are contact elements which are controlled by mechanical magnitudes (for example cylinder paths).

If $INPUT \geq THRESHOLD$, then $VAL = 1$.

Else $VAL = 0$.

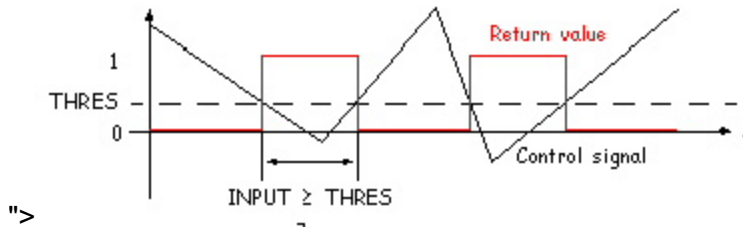

Figure 2. Input signal INPUT AND return value VAL of the Limit Switch 3 model

[Top](#)

Netlist Syntax

```
MODEL LS3 ?InstanceName(@InstanceName):(@ (Rebase)@(ID)) ( THRES:= @THRES,
INPUT:= @INPUT) SRC: DB(Lib:=@ModelLibraryName) ;
```

[Top](#)

Parameters

Table 1

Name	Description	Data Type	Default Value [Unit]
THRES	Threshold Value	real	0

[Top](#)

Input/Output Quantities

Table 2

Name	Description	Data type
INPUT	Input Signal	real
VAL	Return Value	real

[Top](#)

Example

[Top](#)

References

Limit Switch 4

Library: Hydraulic	Modeling Language: SML	Version Number: Twin Builder 2024.2
--------------------	------------------------	-------------------------------------

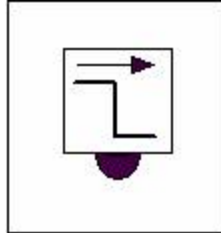

Figure 1. Component symbol

- [Description](#)
- [Assumptions and Limitations](#)
- [Mathematical Description](#)
- [Netlist Syntax](#)
- [Parameters](#)
- [Input/Output Quantities](#)
- [Example](#)
- [References](#)

Description

The model represents a limit switch. If the input signal INPUT is greater than the threshold value THRES, the model returns the value '0', otherwise the model returns the value '1'. The switch return value (switch closed: 1, switch open: 0) is shown visually during the simulation with a red mark in the symbol.

[Top](#)

Assumptions and Limitations

[Top](#)

Mathematical Description

Limit switches are contact elements which are controlled by mechanical magnitudes (for example cylinder paths).

If $INPUT \geq THRESHOLD$, then $VAL = 0$.

Else $VAL = 1$.

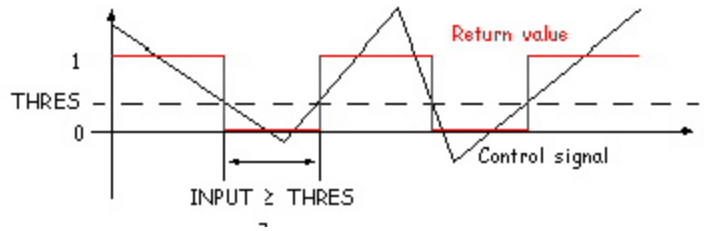

Figure 2. Input signal INPUT AND return value VAL of the Limit Switch 3 model

[Top](#)

Netlist Syntax

```
MODEL LS4 ?InstanceName(@InstanceName):(@ (Rebase)@(ID)) ( THRES:= @THRES,
INPUT:= @INPUT) SRC: DB(Lib:=@ModelLibraryName) ;
```

[Top](#)

Parameters

Table 1

Name	Description	Data Type	Default Value [Unit]
THRES	Threshold Value	real	0

[Top](#)

Input/Output Quantities

Table 2

Name	Description	Data type
INPUT	Input Signal	real
VAL	Return Value	real

[Top](#)

Example

[Top](#)

References

Ideal Switch, Normally Closed

Library: Hydraulic	Modeling Language: SML	Version Number: Twin Builder 2024.2
--------------------	------------------------	-------------------------------------

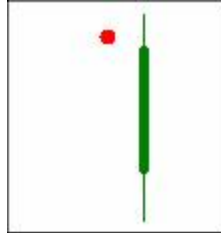

Figure 1. Component symbol

- [Description](#)
- [Assumptions and Limitations](#)
- [Mathematical Description](#)
- [Netlist Syntax](#)
- [Conservative Pins](#)
- [Parameters](#)
- [Example](#)
- [References](#)

Description

The model represents an ideal fluid switch. If the control signal is greater than '0', the two terminal nodes of the switch are disconnected. Because it is an ideal switch, the resistance of the line connection is zero. If the control signal is lower than or equal to '0', the line is connected and the resistance is infinite. A logical signal controls the state of the switch. The initial state of the switch is ON. The ideal switch is represented as an Animated Symbol; that means the switch symbol changes during the simulation depending on the control signal.

Note: Since the switch behaves as an ideal, physically meaningful circuits must be obtained in both ON and OFF switching states.

[Top](#)

Assumptions and Limitations

The model is based on the following assumptions:

- The switch is ideal, *i.e.* the resistance of the line connection is zero when the switch is ON, and infinity when the switch is OFF.

[Top](#)

Mathematical Description

If CTRL ≤ 0, then P = 0.

If CTRL > 0, then Q = 0.

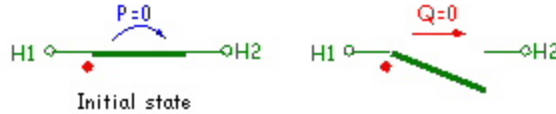

Figure 2. The Ideal Switch model under both ON and OFF operation conditions

[Top](#)

Netlist Syntax

```
MODEL SC_HYD ?InstanceName(@InstanceName):(@ (Refbase)@ (ID)) H1:= %0, H2:= %1 (
CTRL:= @CTRL) SRC: DB(Lib:=@ModelLibraryName);
```

[Top](#)

Conservative Pins

Table 1

Name	Port/Terminal description	Nature/Data type
H1	Fluidic Pin	Fluidic terminal
H2	Fluidic Pin	Fluidic terminal

[Top](#)

Parameters

Table 2

Name	Description	Data Type	Default Value [Unit]
CTRL	Control Signal	real	0

[Top](#)

Example

In this example, the Ideal Switch (Normally Close) SC_HYD1 is switched by a control signal, which is a predefined function that causes switching every 0.5 second. The schematic of the sys-

tem is shown in Figure 3, system parameters are listed in Table 4, and the simulation results are shown in Figure 4.

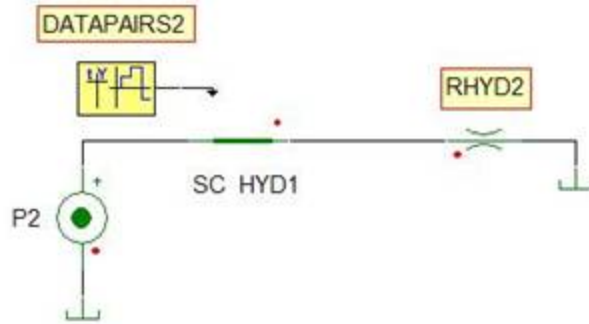

Figure 3. Application example of the Ideal Switch (Normally Close)

Table 3. System Parameters

Component	Parameter	Value [unit]
Pressure Source P2	Value	1Meg [Pa]
RHYD2	K	5n [m ³ /(Pa s)]
SC_HYD1	CRTL	DATAPAIRS.VAL

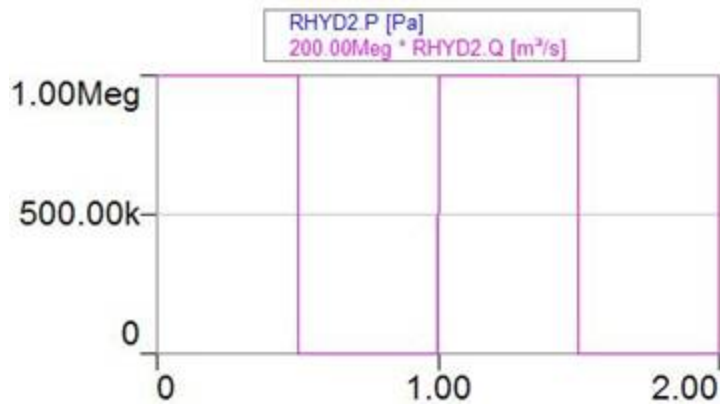

Figure 4. Simulation results

[Top](#)

References

Ideal Switch, Change Over

Library: Hydraulic	Modeling Language: SML	Version Number: Twin Builder 2024.2
--------------------	------------------------	-------------------------------------

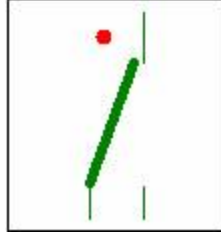

Figure 1. Component symbol

- [Description](#)
- [Assumptions and Limitations](#)
- [Mathematical Description](#)
- [Netlist Syntax](#)
- [Conservative Pins](#)
- [Parameters](#)
- [Example](#)
- [References](#)

Description

The model represents an ideal fluid transfer switch. If the control signal is greater than '0', the nodes H1 and H2 are connected and the nodes H1 and H3 are disconnected. Because it is an ideal switch, the resistance of the line connection is zero and the resistance of the disconnection is infinite. If the control signal is lower than or equal to '0', the line between H1 and H3 is connected. The initial state of the switch is OFF. The ideal switch is represented as an Animated Symbol; that means the switch symbol will change during the simulation depending on the corresponding control signal.

Note: Since the switch behaves as an ideal, physically meaningful circuits must be obtained in both ON and OFF switching states.

[Top](#)

Assumptions and Limitations

The model is based on the following assumptions:

- The switch is ideal, *i.e.* the resistance of the line connection is zero when the switch is ON, and infinity when the switch is OFF.

[Top](#)

Mathematical Description

If CTRL ≤ 0, then $P(H1 \rightarrow H3) = 0$ and $Q(H1 \rightarrow H2) = 0$.

If CTRL > 0, then $P(H1 \rightarrow H2) = 0$ and $Q(H1 \rightarrow H3) = 0$.

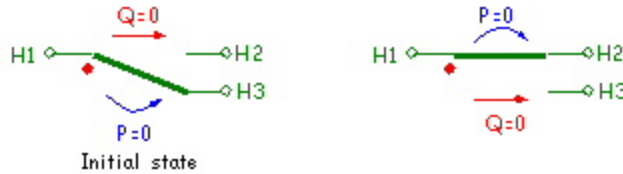

Figure 2. The Ideal Switch model under both ON and OFF operation conditions

[Top](#)

Netlist Syntax

```
MODEL SCO_HYD ?InstanceName(@InstanceName):(@(@Refbase)@(ID)) H1:= %0, H2:= %1,
H3:= %2 ( CTRL:= @CTRL) SRC: DB(Lib:=@ModelLibraryName) ;
```

[Top](#)

Conservative Pins

Table 1

Name	Port/Terminal description	Nature/Data type
H1	Fluidic Pin	Fluidic terminal
H2	Fluidic Pin	Fluidic terminal
H3	Fluidic Pin	Fluidic terminal

[Top](#)

Parameters

Table 2

Name	Description	Data Type	Default Value [Unit]
CTRL	Control Signal	real	0

[Top](#)

Example

In this example, the Ideal Switch (Change Over) SCO_HYD1 is switched by a control signal, which is a predefined function that causes switching every 0.5 second. The schematic of the system is shown in Figure 3, system parameters are listed in Table 4, and the simulation results are shown in Figure 4.

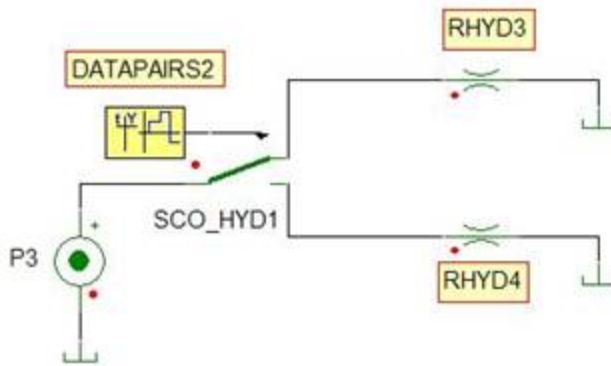

Figure 3. Application example of the Ideal Switch (Change Over)

Table 3. System Parameters

Component	Parameter	Value [unit]
Pressure Source P3	Value	1Meg [Pa]
RHYD3	K	3n [m ³ /(Pa s)]
RHYD4	K	5n [m ³ /(Pa s)]
SCO_HYD1	CRTL	DATAPAIRS.VAL

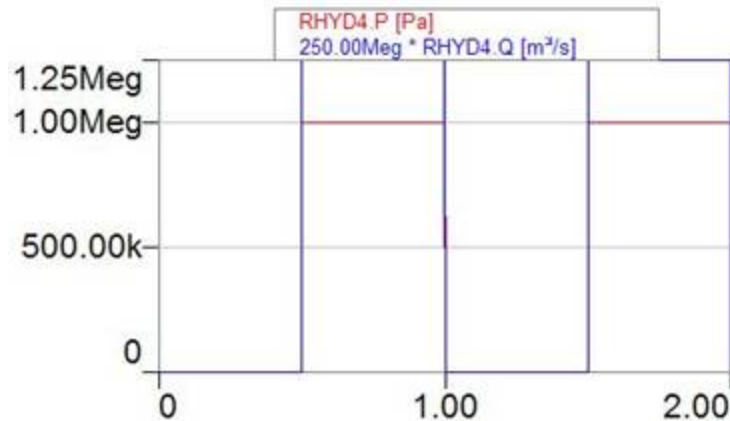
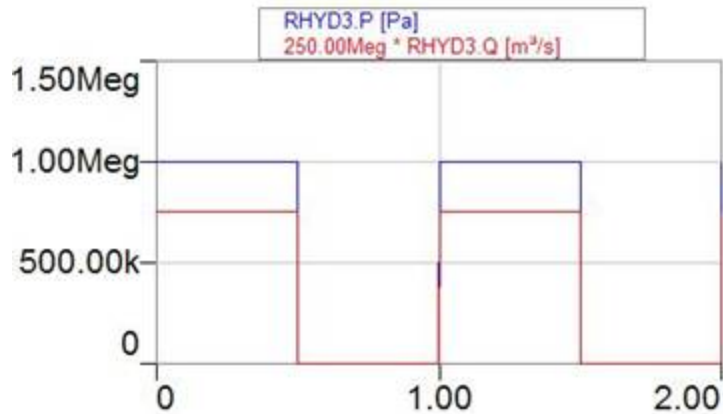

Figure 4. Simulation results

[Top](#)

References

Ideal Switch, Normally Open

Library: Hydraulic	Modeling Language: SML	Version Number: Twin Builder 2024.2
--------------------	------------------------	-------------------------------------

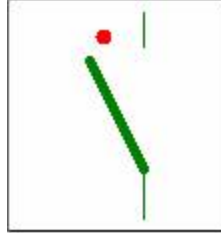

Figure 1. Component symbol

- [Description](#)
- [Assumptions and Limitations](#)
- [Mathematical Description](#)
- [Netlist Syntax](#)
- [Conservative Pins](#)
- [Parameters](#)
- [Example](#)
- [References](#)

Description

The model represents an ideal fluid switch. If the control signal is greater than '0', the two terminal nodes of the switch are connected. Because it is an ideal switch, the resistance of the line connection is zero. If the control signal is lower than or equal to '0', the line is disconnected and the resistance is infinite. A logical signal controls the state of the switch. The initial state of the switch is OFF. The ideal switch is represented as an Animated Symbol; that means the switch symbol changes during the simulation depending on the control signal.

Note: Since the switch behaves as an ideal, physically meaningful switch, circuits must be obtained in both ON and OFF switching states.

[Top](#)

Assumptions and Limitations

The model is based on the following assumptions:

- The switch is ideal, *i.e.* the resistance of the line connection is zero when the switch is ON, and infinity when the switch is OFF.

[Top](#)

Mathematical Description

If CTRL ≤ 0, then Q = 0.

If CTRL > 0, then P = 0.

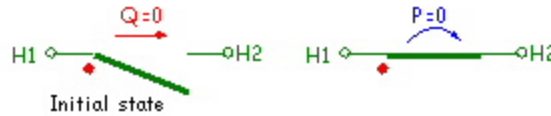

Figure 2. The Ideal Switch model under both ON and OFF operation conditions

[Top](#)

Netlist Syntax

```
MODEL SO_HYD ?InstanceName(@InstanceName):(@ (Refbase)@(ID)) H1:= %0, H2:= %1 (
CTRL:= @CTRL) SRC: DB(Lib:=@ModelLibraryName);
```

[Top](#)

Conservative Pins

Table 1

Name	Port/Terminal description	Nature/Data type
H1	Fluidic Pin	Fluidic terminal
H2	Fluidic Pin	Fluidic terminal

[Top](#)

Parameters

Table 2

Name	Description	Data Type	Default Value [Unit]
CTRL	Control Signal	real	0

[Top](#)

Example

In this example, the Ideal Switch (Normally Open) SO_HYD1 is switched by a control signal, which is a predefined function that causes switching every 0.5 second. The schematic of the sys-

tem is shown in Figure 3, system parameters are listed in Table 4, and the simulation results are shown in Figure 4.

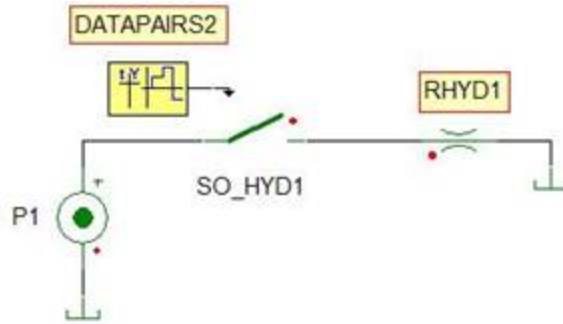

Figure 3. Application example of the Ideal Switch (Normally Open)

Table 3. System Parameters

Component	Parameter	Value [unit]
Pressure Source P1	Value	1Meg [Pa]
RHYD1	K	5n [m ³ /(Pa s)]
SO_HYD1	CRTL	DATAPAIRS.VAL

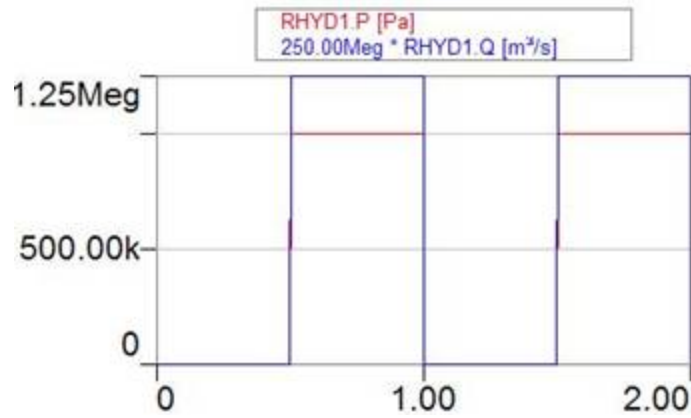

Figure 4. Simulation results

[Top](#)

References

Pressure Switch

Library: Hydraulic

Modeling Language: SML

Version Number: Twin Builder 2024.2

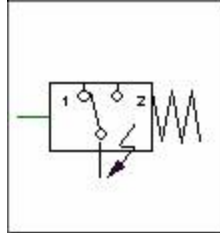

Figure 1. Component symbol

- [Description](#)
- [Assumptions and Limitations](#)
- [Mathematical Description](#)
- [Netlist Syntax](#)
- [Conservative Pins](#)
- [Parameters](#)
- [Input/Output Quantities](#)
- [Example](#)
- [References](#)

Description

The model represents a pressure switch that switches one break contact *VAL1* (default value '1') and one make contact *VAL2* (default value '0') if the applied oil pressure at the fluidic pin exceeds the set switching pressure *THRES*. The switch has a hysteresis *HYST*, which is necessary for stability when the model is used for 2-point regulation (for example switching pumps ON and OFF depending on pressure).

[Top](#)

Assumptions and Limitations

[Top](#)

Mathematical Description

The simulator synchronizes on the switching points with minimum time step *HMIN*. The switch setting is shown during the simulation.

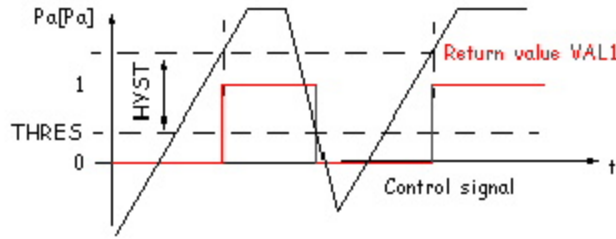

Figure 2. Control signal response to applied pressure at H1 of the Pressure Switch.

[Top](#)

Netlist Syntax

```
MODEL SP_HYD ?InstanceName(@InstanceName):(@ (Refbase)@(ID)) H1:= %0 ( HYST:=
@HYST, THRES:= @THRES) SRC: DB(Lib:=@ModelLibraryName) ;
```

[Top](#)

Conservative Pins

Table 1

Name	Port/Terminal description	Nature/Data type
H1	Fluidic Pin	Fluidic terminal

[Top](#)

Parameters

Table 2

Name	Description	Data Type	Default Value [Unit]
HYST	Hysteresis [Pa]	real	0
THRES	Threshold Value [Pa]	real	0

[Top](#)

Input/Output Quantities

Table 3

Name	Description	Data type
VAL1	Value 1 (represents break contact)	real
VAL2	Value 2 (represents make contact)	real

[Top](#)

Example

[Top](#)

References

Hydraulic Valves

The actuating units which are shown as magnets stand symbolically for any arbitrary actuating unit (hydraulic, mechanical etc.), since this is not significant for the hydrostatic simulation. The same applies to pre-controlled directional valves. Pressure losses in the valves during oil flow are not modeled. During the simulation, the valve switch setting is shown by animation. The Hydraulic>Valves library is organized as follows:

- [Directional Control Valves](#)
- [Non-Return Valves](#)
- [Pressure Control Valves](#)

Directional Control Valves

The models represent ideal directional control valves that release or block paths for the oil flow. The directional control valves folder consists of sub-types 2-2, 3-2, 4-2, and 4-3 as listed below.

NOTE: Because of the commonality between models in each type, the documentation for all models of a given type is provided in a common topic link.

- [Directional Control Valves, 2-2](#)

Because of commonality between type 2-2 Directional Control Valve models, documentation is provided in the common [2-2](#) topic.

The following 2-2 valve models are available:

- [Function 1 \(VW_22_1\)](#)
- [Function 2 \(VW_22_2\)](#)

- [Directional Control Valves, 3-2](#)

Because of commonality between type 3-2 Directional Control Valve models, documentation is provided in the common [3-2](#) topic.

The following 3-2 valve models are available:

- [Function 1 \(VW_32_1\)](#)
- [Function 2 \(VW_32_2\)](#)

- [Directional Control Valves, 4-2](#)

Because of commonality between type 4-2 Directional Control Valve models, documentation is provided in the common [4-2](#) topic.

The following 4-2 valve models are available:

OFF Function

- [Function 1 \(VW_420_1\)](#)
- [Function 2 \(VW_420_2\)](#)
- [Function 3 \(VW_420_3\)](#)
- [Function 4 \(VW_420_4\)](#)
- [Function 5 \(VW_420_5\)](#)
- [Function 6 \(VW_420_6\)](#)
- [Function 7 \(VW_420_7\)](#)
- [Function 8 \(VW_420_8\)](#)

ON Function

- [Function 1 \(VW_421_1\)](#)
- [Function 2 \(VW_421_2\)](#)
- [Function 3 \(VW_421_3\)](#)
- [Function 4 \(VW_421_4\)](#)
- [Function 5 \(VW_421_5\)](#)
- [Function 6 \(VW_421_6\)](#)

- Function 7 (VW_421_7)
- Function 8 (VW_421_8)

- Directional Control Valves, 4-3

Because of commonality between type 4-3 Directional Control Valve models, documentation is provided in the common [4-3](#) topic.

The following 4-3 valve models are available:

- Function 1 (VW_43_1)
- Function 2 (VW_43_2)
- Function 3 (VW_43_3)
- Function 4 (VW_43_4)
- Function 5 (VW_43_5)
- Function 6 (VW_43_6)

Directional Control Valves, 2-2

Library: Hydraulic

Modeling Language: SML

Version Number: Twin Builder 2024.2

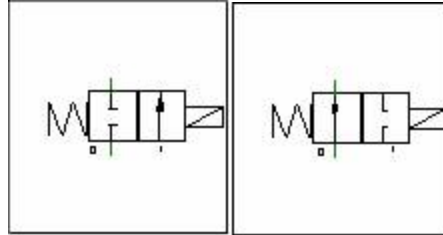

Figure 1. Component symbols

- [Description](#)
- [Assumptions and Limitations](#)
- [Mathematical Description](#)
- [Netlist Syntax](#)
- [Conservative Pins](#)
- [Parameters](#)
- [Example](#)
- [References](#)

Description

The model represents an ideal directional control valve that releases or blocks paths for the oil flow. The 2-2 valve has two controlled connections and two switch settings. The model Function 1 releases the path in position 1, the model Function 2 releases the path in position 0. During the simulation, there is an animation of the directional valve switch setting.

[Top](#)

Assumptions and Limitations

[Top](#)

Mathematical Description

If $CTRL > 0$, then Valve is in Position 1.

If $CTRL \leq 0$, then Valve is in Position 0.

[Top](#)

Netlist Syntax

```
MODEL VW_22_1 ?InstanceName(@InstanceName):(@ (Refbase)@(ID)) H1:= %0, H2:= %1 (
CTRL:= @CTRL) SRC: DB(Lib:=@ModelLibraryName);
```

```
MODEL VW_22_2 ?InstanceName(@InstanceName):(@ (Refbase)@(ID)) H2:= %0, H1:= %1 (
CTRL:= @CTRL) SRC: DB(Lib:=@ModelLibraryName);
```

[Top](#)

Conservative Pins

Table 1

Name	Port/Terminal description	Nature/Data type
H1	Fluidic Pin	Fluidic terminal
H2	Fluidic Pin	Fluidic terminal

[Top](#)

Parameters

Table 2

Name	Description	Data Type	Default Value [Unit]
CTRL	Control Signal	real	0

[Top](#)

Example

In this example, both valves switch at $t = 0.5$ s, and stop the flow through them. The schematic of the system is shown in Figure 2, system parameters are listed in Table 3, and the simulation results are shown in Figure 3.

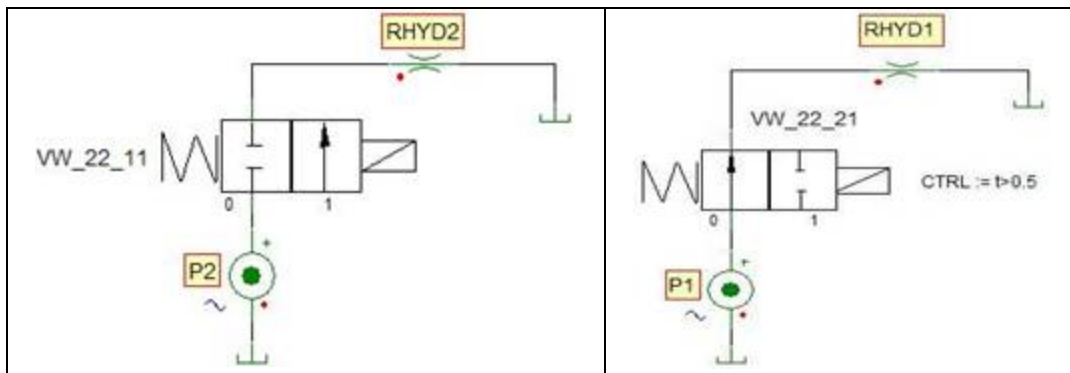
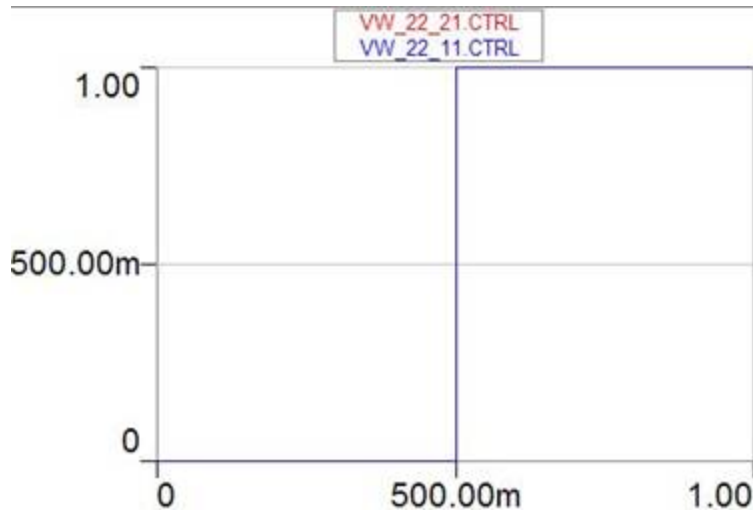

Figure 2. Application example of the Directional Control Valve (2-2) Function 1 and Function 2

Table 3. System Parameters

Component	Parameter	Value [unit]
Pressure Source P1 (Time Controller_ Sine)	Amplitude	500K [Pa]
	Frequency	1 [Hz]
	Delay	0 [s]
	Phase	0 [Deg]
	Offset	1Meg [Pa]
Pressure Source P2 (Time Controller_ Sine)	Amplitude	500K [Pa]
	Frequency	1 [Hz]
	Delay	0 [s]
	Phase	0 [Deg]
	Offset	1Meg [Pa]
Directional Control Valve VW22_11	CTRL	t > 0.5s
Directional Control Valve VW22_21	CTRL	t > 0.5s
RHYD1	K	3n [m ³ /(Pa s)]
RHYD2	K	3n [m ³ /(Pa s)]



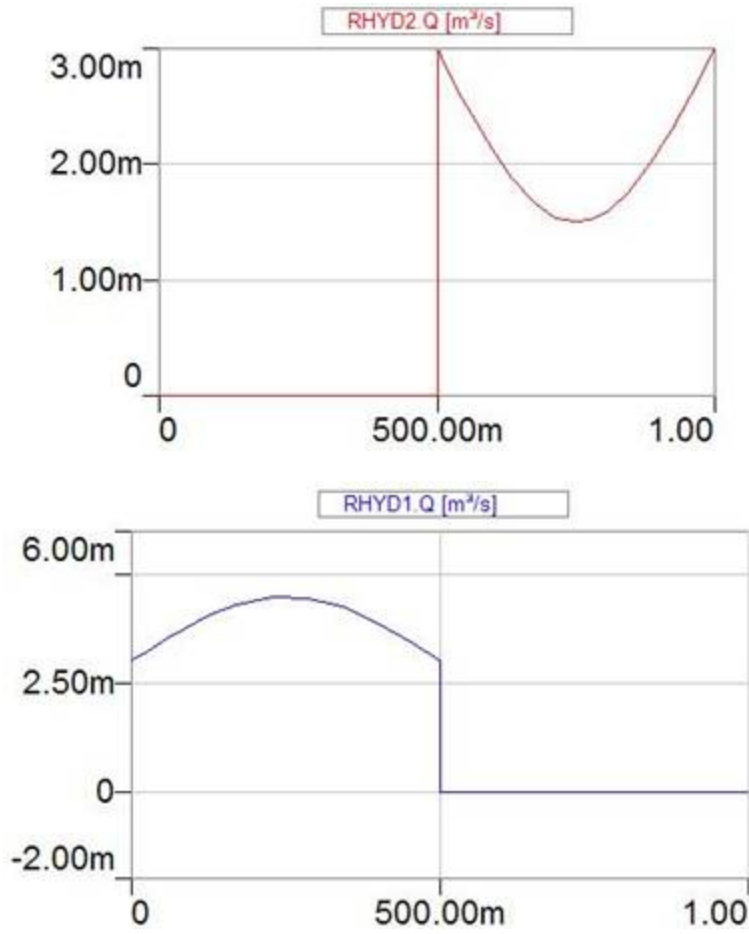

Figure 3. Simulation results

[Top](#)

References

Directional Control Valves, 3-2

Library: Hydraulic

Modeling Language: SML

Version Number: Twin Builder 2024.2

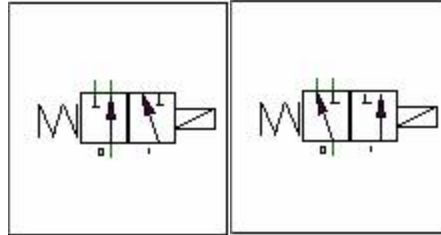

Figure 1. Component symbols

- [Description](#)
- [Assumptions and Limitations](#)
- [Mathematical Description](#)
- [Netlist Syntax](#)
- [Conservative Pins](#)
- [Parameters](#)
- [Example](#)
- [References](#)

Description

The model represents an ideal directional control valve that releases or blocks paths for the oil flow. The 3-2 valve has three controlled connections and two switch settings. The model Function 1 releases the path H1-H2 in position 0 and H1-H3 in position 1, the model Function 2 releases the path H1-H2 in position 1 and H1-H3 in position 0. During the simulation, there is an animation of the directional valve switch setting.

[Top](#)

Assumptions and Limitations

[Top](#)

Mathematical Description

If $CTRL > 0$, then Valve is in Position 1.

If $CTRL \leq 0$, then Valve is in Position 0.

[Top](#)

Netlist Syntax

```
MODEL VW_32_1 ?InstanceName(@InstanceName):(@Refbase)@(ID)) H1:= %0, H2:= %1,
H3:= %2 ( CTRL:= @CTRL) SRC: DB(Lib:=@ModelLibraryName) ;
```

```
MODEL VW_32_2 ?InstanceName(@InstanceName):(@Refbase)@(ID)) H1:= %0, H2:= %1,
H3:= %2 ( CTRL:= @CTRL) SRC: DB(Lib:=@ModelLibraryName) ;
```

[Top](#)

Conservative Pins

Table 1

Name	Port/Terminal description	Nature/Data type
H1	Fluidic Pin	Fluidic terminal
H2	Fluidic Pin	Fluidic terminal
H3	Fluidic Pin	Fluidic terminal

[Top](#)

Parameters

Table 2

Name	Description	Data Type	Default Value [Unit]
CTRL	Control Signal	real	0

[Top](#)

Example

In this example, the Direction Control Valve (3-2) Function 2 VW_32_21 switch at $t = 1$ s, and redirect the flow from RHYD1 to RHYD2. The schematic of the system is shown in Figure 2, system parameters are listed in Table 3, and the simulation results are shown in Figure 3.

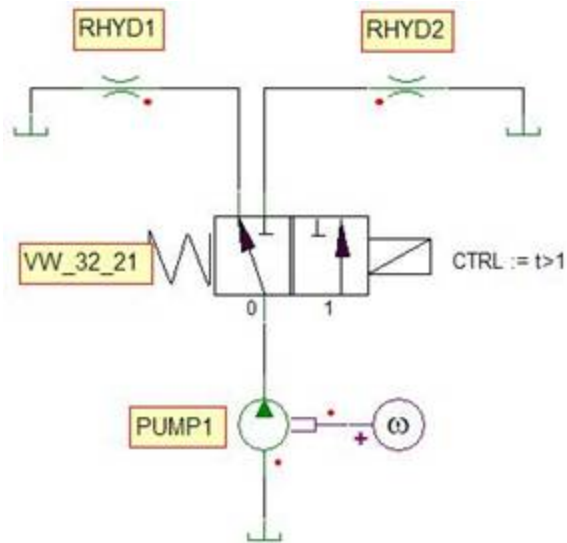
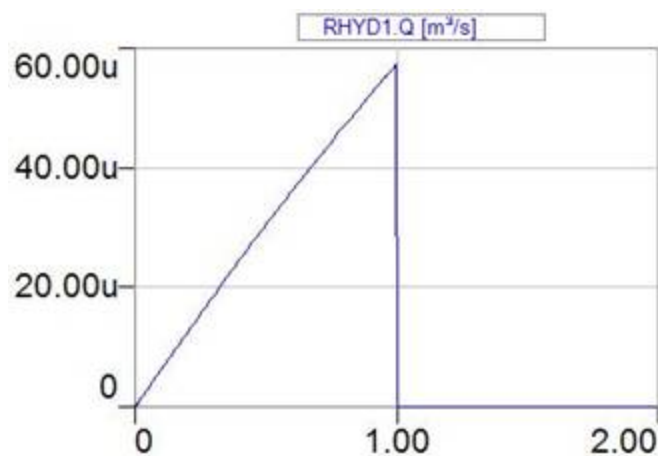

Figure 2. Application example of the Direction Control Valve (3-2) Function 2 model

Table 3. System Parameters

Component	Parameter	Value [unit]
Pump PUMP1	VOLG	$2 \cdot \pi \cdot 1 \text{u}$ [m ³]
Angular Velocity Source V_ROT1	VALUE	$2 \cdot \pi \cdot 10 \cdot t$ [rad/s]
Directional Control Valve VW32_21	CTRL	$t > 1 \text{ s}$
RHYD1	K	$5 \text{E-}12$ [m ³ /(Pa s)]
RHYD2	K	$5 \text{E-}12$ [m ³ /(Pa s)]



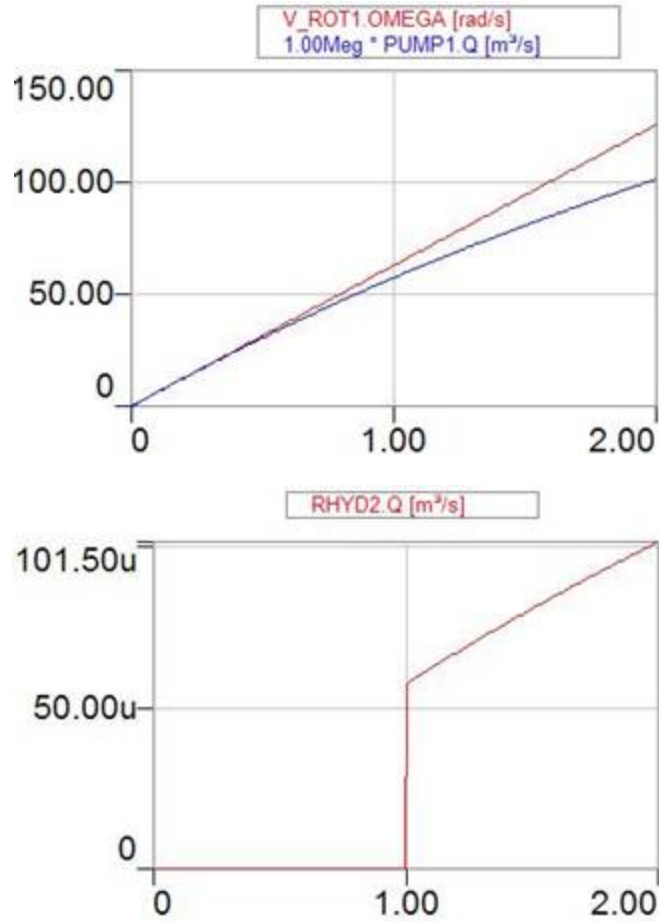

Figure 3. Simulation results

[Top](#)

References

Directional Control Valves, 4-2

Library: Hydraulic	Modeling Language: SML	Version Number: Twin Builder 2024.2
--------------------	------------------------	-------------------------------------

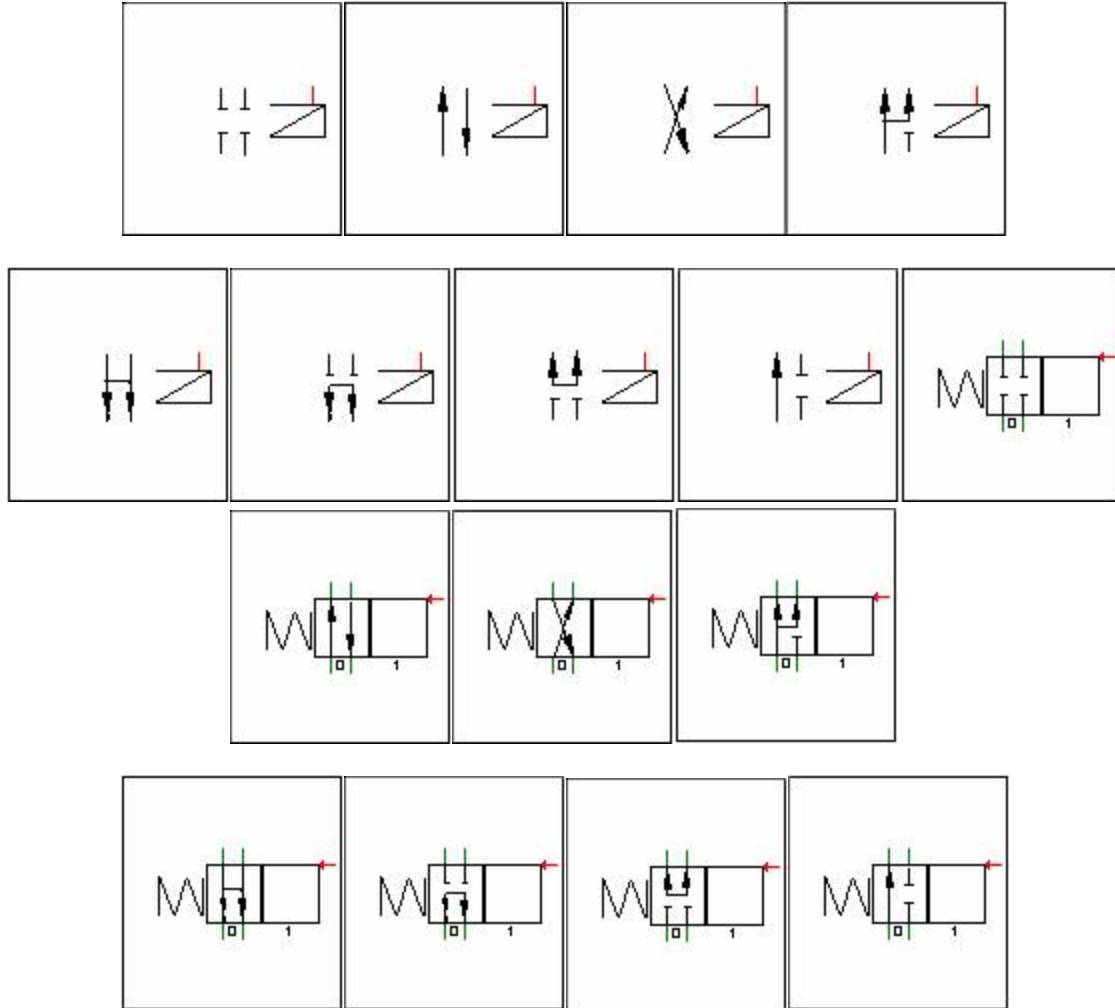

Figure 1. Component symbols

- [Description](#)
- [Netlist Syntax](#)
- [Conservative Pins](#)
- [Parameters](#)
- [Input/Output Quantities](#)
- [Example](#)
- [References](#)

Description

The models represent ideal directional control valves that release or block paths for the oil flow. The 4-2 valve has four controlled connections and two switch settings. During simulation, there is an animation of the directional valve switch setting.

OFF Functions (Controlling Units)

The number of different channel connections in a switch setting is limited. The Hydraulic Library provides the 8 most important channel connections, which are shown in the following figure in the valve idle setting (unpowered actuating unit).

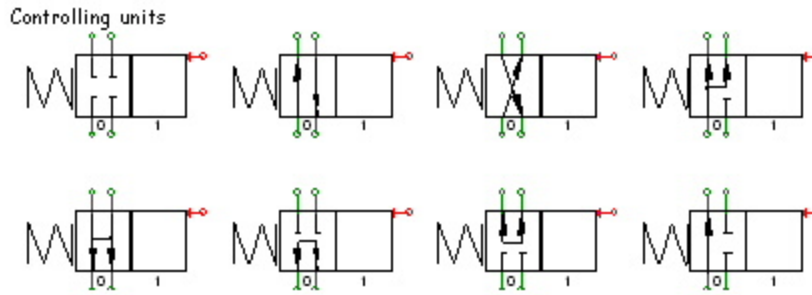

Figure 2. Eight most important channel connections in the Hydraulic library

ON Functions (Actuating Units)

The same channel connections exist for the working position of the valve (actuated actuating unit).

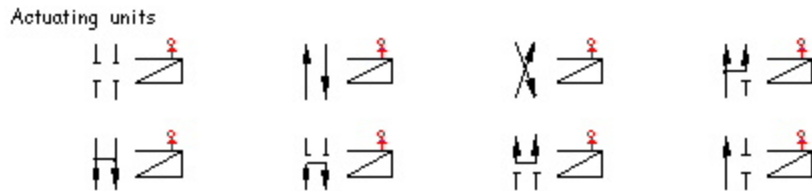

Figure 3. Working positions of the valve

Combination of Controlling and Actuating Units

All possible combinations of a controlling and an actuating unit leads to 112 different valves. One controlling and one actuating unit must be placed on the top of each other. The control signal CTRL is defined in the actuating unit (control signal ≤ 0 idle setting, control signal > 0 working setting). The set output value of the actuating unit must be connected with the set input value of the controlling unit (red pins).

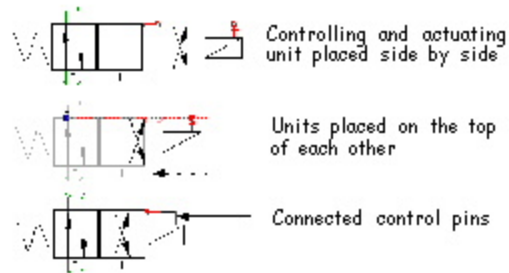

Figure 4. Combinations of controlling and actuating units

Valve Positions

During simulation, there is an animation of the directional valve switch setting. The idle and working position is displayed on the sheet depending on the control signal.

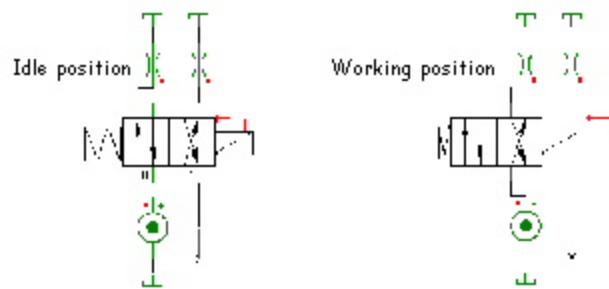

Figure 5. Directional valve under working and idle conditions

Top

Netlist Syntax

```
MODEL VW_421_1 ?InstanceName(@InstanceName):(@ (Refbase)@ (ID)) ( CTRL:= @CTRL)
SRC: DB(Lib:=@ModelLibraryName) ;
```

```
MODEL VW_421_2 ?InstanceName(@InstanceName):(@ (Refbase)@ (ID)) ( CTRL:= @CTRL)
SRC: DB(Lib:=@ModelLibraryName) ;
```

```
MODEL VW_421_3 ?InstanceName(@InstanceName):(@ (Refbase)@ (ID)) ( CTRL:= @CTRL)
SRC: DB(Lib:=@ModelLibraryName) ;
```

```
MODEL VW_421_4 ?InstanceName(@InstanceName):(@ (Refbase)@ (ID)) ( CTRL:= @CTRL)
SRC: DB(Lib:=@ModelLibraryName) ;
```

```
MODEL VW_421_5 ?InstanceName(@InstanceName):(@ (Refbase)@ (ID)) ( CTRL:= @CTRL)
SRC: DB(Lib:=@ModelLibraryName) ;
```

```
MODEL VW_421_6 ?InstanceName(@InstanceName):(@ (Refbase)@ (ID)) ( CTRL:= @CTRL)
SRC: DB(Lib:=@ModelLibraryName) ;
```

MODEL VW_421_7 ?InstanceName(@InstanceName):(@Refbase@ID) (CTRL:= @CTRL)
 SRC: DB(Lib:=@ModelLibraryName) ;

MODEL VW_421_8 ?InstanceName(@InstanceName):(@Refbase@ID) (CTRL:= @CTRL)
 SRC: DB(Lib:=@ModelLibraryName) ;

MODEL VW_420_1 ?InstanceName(@InstanceName):(@Refbase@ID) H1:= %0, H2:= %1,
 H3:= %2, H4:= %3 (SET:= @SET) SRC: DB(Lib:=@ModelLibraryName) ;

MODEL VW_420_2 ?InstanceName(@InstanceName):(@Refbase@ID) H1:= %0, H2:= %1,
 H3:= %2, H4:= %3 (SET:= @SET) SRC: DB(Lib:=@ModelLibraryName) ;

MODEL VW_420_3 ?InstanceName(@InstanceName):(@Refbase@ID) H1:= %0, H2:= %1,
 H3:= %2, H4:= %3 (SET:= @SET) SRC: DB(Lib:=@ModelLibraryName) ;

MODEL VW_420_4 ?InstanceName(@InstanceName):(@Refbase@ID) H1:= %0, H2:= %1,
 H3:= %2, H4:= %3 (SET:= @SET) SRC: DB(Lib:=@ModelLibraryName) ;

MODEL VW_420_5 ?InstanceName(@InstanceName):(@Refbase@ID) H1:= %0, H2:= %1,
 H3:= %2, H4:= %3 (SET:= @SET) SRC: DB(Lib:=@ModelLibraryName) ;

MODEL VW_420_6 ?InstanceName(@InstanceName):(@Refbase@ID) H1:= %0, H2:= %1,
 H3:= %2, H4:= %3 (SET:= @SET) SRC: DB(Lib:=@ModelLibraryName) ;

MODEL VW_420_7 ?InstanceName(@InstanceName):(@Refbase@ID) H1:= %0, H2:= %1,
 H3:= %2, H4:= %3 (SET:= @SET) SRC: DB(Lib:=@ModelLibraryName) ;

MODEL VW_420_8 ?InstanceName(@InstanceName):(@Refbase@ID) H1:= %0, H2:= %1,
 H3:= %2, H4:= %3 (SET:= @SET) SRC: DB(Lib:=@ModelLibraryName) ;

[Top](#)

Conservative Pins

Table 1

Name	Port/Terminal description	Nature/Data type
H1	Fluidic Pin	Fluidic terminal
H2	Fluidic Pin	Fluidic terminal
H3	Fluidic Pin	Fluidic terminal
H4	Fluidic Pin	Fluidic terminal

[Top](#)

Parameters

Table 2

Name	Description	Data Type	Default Value [Unit]
------	-------------	-----------	----------------------

CTRL	Control Signal	real	0
------	----------------	------	---

[Top](#)

Input/Output Quantities

Table 3

Name	Description	Data type
SET_INPUT	Value of controlling unit to set position, (control signal 0 idle setting, control signal 0 working setting)	real
SET_OUTPUT	Control signal of actuating unit to set position, (control signal 0 idle setting, control signal 0 working setting)	real

[Top](#)

Example

In this example, a constant pressure causes a constant flow in the laminar orifice RHYD1. After 1sec the valve switches and the the pressure is then provided to RHYD2, resulting in a flow through RHYD2. The blind plug is used to close the open hydraulic pin at the valve. The schematic of the system is shown in Figure 6, system parameters are listed in Table 3, and the simulation results are shown in Figure 7.

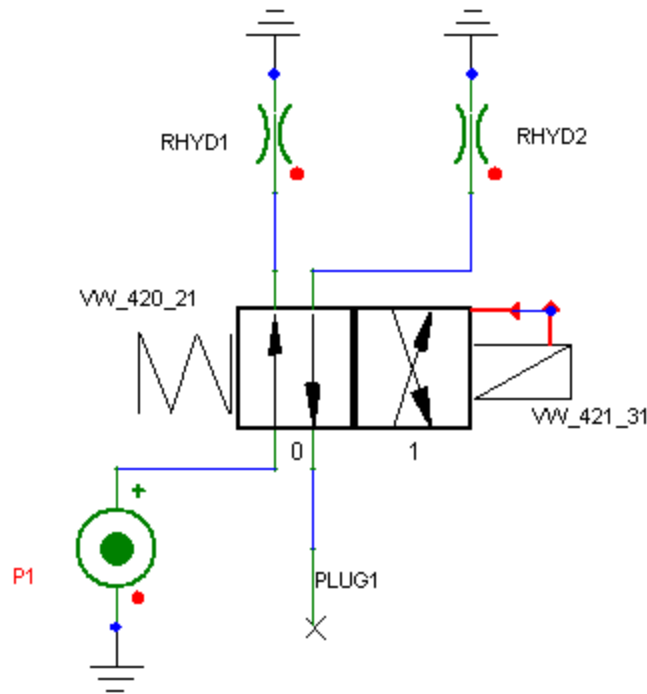

Figure 6. Application example of the Directional Control Valve (4-2).

Table 3. System Parameters

Component	Parameter	Value [unit]
Pressure Source P1	Amplitude	1e+006 [Pa]
Linear Orifice RHYD1	Hydraulic Conductance	1e-009 [m ³ /Pa]
	Differential Pressure	0 [Pa]
	Flow Rate	0 [m ³ /s]
Linear Orifice RHYD2	Hydraulic Conductance	3e-009 [m ³ /Pa]
	Differential Pressure	0 [Pa]
	Flow Rate	0 [m ³ /s]
Directional Control Valve VW_420_21	Value to set ON function (SET)	VW_421_31.SET
Directional Control Valve VW_421_31	CTRL	time > 1s
	Value to set ON function (SET)	0

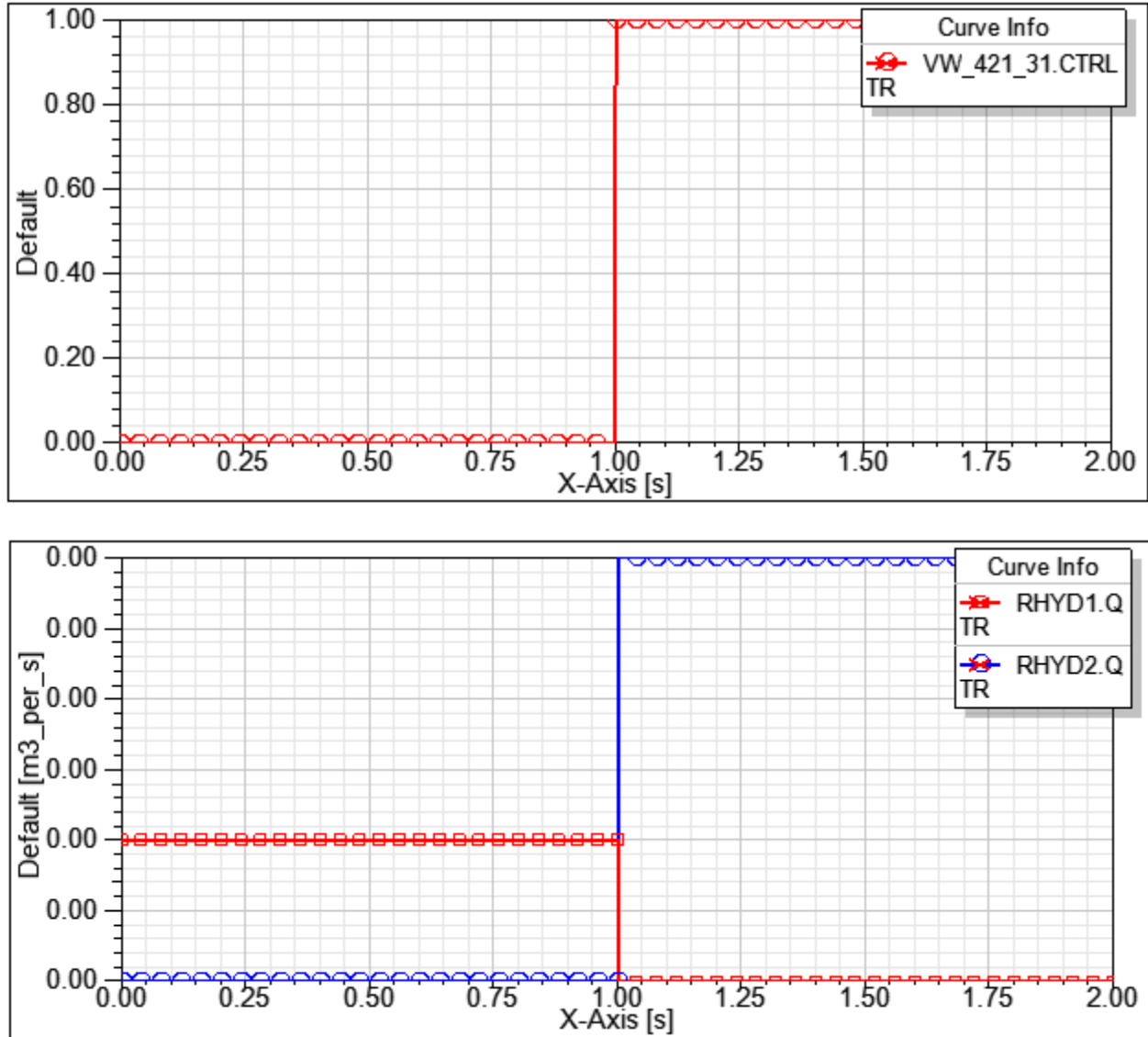

Figure 7. Simulation results

[Top](#)

References

Directional Control Valves, 4-3

Library: Hydraulic	Modeling Language: SML	Version Number: Twin Builder 2024.2
--------------------	------------------------	-------------------------------------

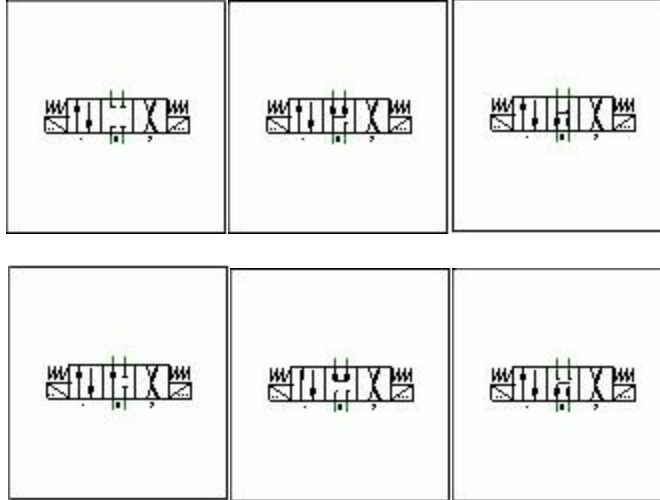

Figure 1. Component symbol

- [Description](#)
- [Assumptions and Limitations](#)
- [Mathematical Description](#)
- [Netlist Syntax](#)
- [Conservative Pins](#)
- [Parameters](#)
- [Example](#)
- [References](#)

Description

The models represent ideal directional control valves that release or block paths for the oil flow. The 4-3 valve has four controlled connections and three switch settings. During simulation, there is an animation of the directional valve switch setting.

[Top](#)

Assumptions and Limitations

[Top](#)

Mathematical Description

If CTRL = 0, the actuating unit is not actuated. If CTRL = 1, the actuating unit is switched ON. If the switch setting is CTRL1=CTRL2=1, then an error message is displayed and the simulation is interrupted.

If CTRL1 <= 0 AND CTRL2 <= 0, then Valve is in Position 0.

If CTRL1 > 0 AND CTRL2 <= 0, then Valve is in Position 1.

If CTRL1 <= 0 AND CTRL2 > 0, then Valve is in Position 2.

If CTRL1 > 0 AND CTRL2 > 0, then Error.

[Top](#)

Netlist Syntax

```
MODEL VW_43_1 ?InstanceName(@InstanceName):(@ (Refbase)@(ID)) H1:= %0, H2:= %1,
H3:= %2, H4:= %3 ( CTRL1:= @CTRL1, CTRL2:= @CTRL2) SRC: DB(Lib:-
:=@ModelLibraryName) ;
```

```
MODEL VW_43_2 ?InstanceName(@InstanceName):(@ (Refbase)@(ID)) H1:= %0, H2:= %1,
H3:= %2, H4:= %3 ( CTRL1:= @CTRL1, CTRL2:= @CTRL2) SRC: DB(Lib:-
:=@ModelLibraryName) ;
```

```
MODEL VW_43_3 ?InstanceName(@InstanceName):(@ (Refbase)@(ID)) H1:= %0, H2:= %1,
H3:= %2, H4:= %3 ( CTRL1:= @CTRL1, CTRL2:= @CTRL2) SRC: DB(Lib:-
:=@ModelLibraryName) ;
```

```
MODEL VW_43_4 ?InstanceName(@InstanceName):(@ (Refbase)@(ID)) H1:= %0, H2:= %1,
H3:= %2, H4:= %3 ( CTRL1:= @CTRL1, CTRL2:= @CTRL2) SRC: DB(Lib:-
:=@ModelLibraryName) ;
```

```
MODEL VW_43_5 ?InstanceName(@InstanceName):(@ (Refbase)@(ID)) H1:= %0, H2:= %1,
H3:= %2, H4:= %3 ( CTRL1:= @CTRL1, CTRL2:= @CTRL2) SRC: DB(Lib:-
:=@ModelLibraryName) ;
```

```
MODEL VW_43_6 ?InstanceName(@InstanceName):(@ (Refbase)@(ID)) H1:= %0, H2:= %1,
H3:= %2, H4:= %3 ( CTRL1:= @CTRL1, CTRL2:= @CTRL2) SRC: DB(Lib:-
:=@ModelLibraryName) ;
```

[Top](#)

Conservative Pins

Table 1

Name	Port/Terminal description	Nature/Data type
H1	Fluidic Pin	Fluidic terminal
H2	Fluidic Pin	Fluidic terminal

H3	Fluidic Pin	Fluidic terminal
H4	Fluidic Pin	Fluidic terminal

[Top](#)

Parameters

Table 2

Name	Description	Data Type	Default Value [Unit]
CTRL1	Control Signal 1	real	0
CTRL2	Control Signal 2	real	0

[Top](#)

Example

In this example, the control signals CTRL1 and CTRL2 of Direction Control Valve (4-3) Function 1 VW_43_11 are decided by two predefined time function, illustrated as follows:

- $0s \leq t \leq 1s$, the valve is in setting 0, there is no fluid flow through either RHYD1 or RHYD2;
- $1s \leq t \leq 2s$, the valve is in setting 1, the Pressure Source P1 is connected to RHYD1, and P2 is connected to RHYD2;
- $2s \leq t < 3s$, the valve is in setting 2, the Pressure Source P1 is connected to RHYD2, and P2 is connected to RHYD1;
- $t = 3s$, Error setting, simulation either aborts or uses previous setting.

The schematic of the system is shown in Figure 2, system parameters are listed in Table 3, and the simulation results are shown in Figure 3.

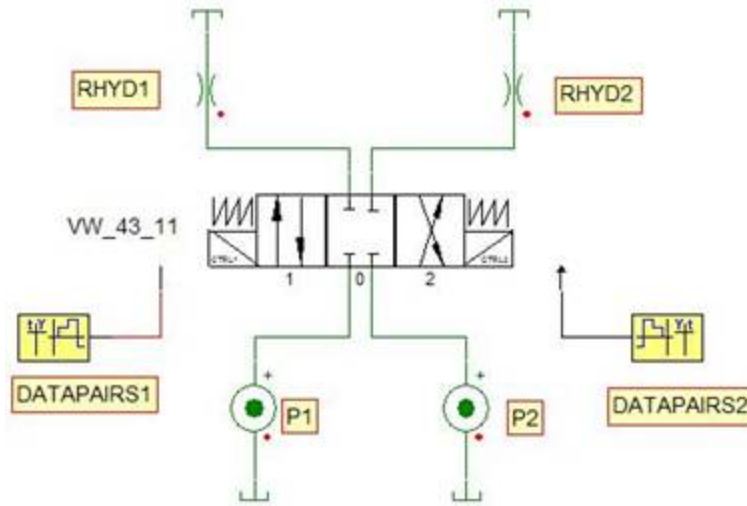

Figure 2. Application example of the Direction Control Valve (4-3) Function1 model

Table 3. System Parameters

Component	Parameter	Value [unit]
Pressure Source P1	VALUE	1Meg [Pa]
Pressure Source P2	VALUE	0.5Meg [Pa]
VW43_11	CTRL1	DATAPAIRS1.VAL
	CTRL2	DATAPAIRS2.VAL
RHYD1	K	1n [m ³ /(Pa s)]
RHYD2	K	3n [m ³ /(Pa s)]



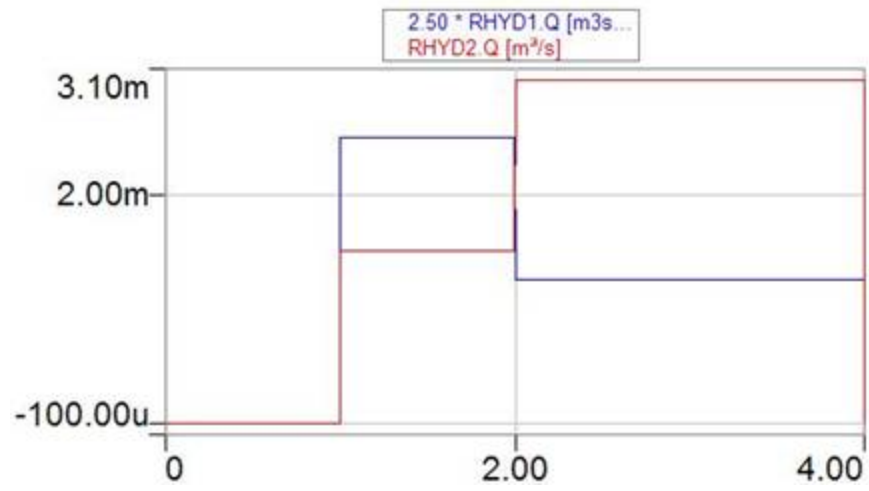

Figure 3. Simulation results

[Top](#)

References

Non-Return Valves

Non-Return Valves let the oil flow through in the flow-permitting direction and blocks it in the other direction (diode function). An opening pressure is required for flow to be permitted. This library contains the following model:

- [Spring Loaded \(VALVE_NR_SPR\)](#)

Non-Return-Valve, Spring-Loaded

Library: Hydraulic

Modeling Language: SML

Version Number: Twin Builder 2024.2

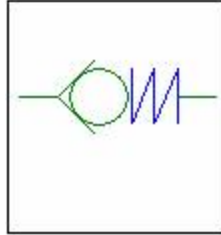

Figure 1. Component symbol

- [Description](#)
- [Assumptions and Limitations](#)
- [Mathematical Description](#)
- [Netlist Syntax](#)
- [Conservative Pins](#)
- [Parameters](#)
- [Input/Output Quantities](#)
- [Example](#)
- [References](#)

Description

The Non-Return Valve lets the oil flow through in the flow-permitting direction and blocks it in the other (diode function). An opening pressure is required for flow to be permitted.

[Top](#)

Assumptions and Limitations

[Top](#)

Mathematical Description

$$\text{If } P \geq P_{\text{OPEN}} \quad Q = \frac{P - P_{\text{OPEN}}}{\text{SLOPE}}$$

$$\text{If } P < P_{\text{OPEN}} \quad Q = \frac{P}{10^{12}}$$

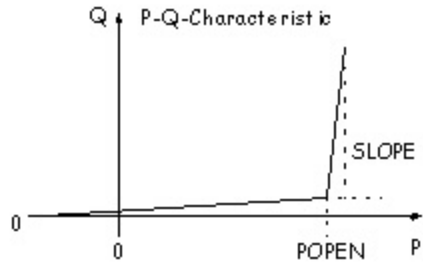

Figure 2. P-Q Characteristic of the Spring Loaded model

[Top](#)

Netlist Syntax

```
MODEL VALVE_NR_SPR ?InstanceName(@InstanceName):(@ (Refbase)@(ID)) H1:= %0,
H2:= %1 ( POPEN:= @POPEN, SLOPE:= @SLOPE) SRC: DB(Lib:=@ModelLibraryName);
```

[Top](#)

Conservative Pins

Table 1

Name	Port/Terminal description	Nature/Data type
H1	Fluidic Pin	Fluidic terminal
H2	Fluidic Pin	Fluidic terminal

[Top](#)

Parameters

Table 2

Name	Description	Data Type	Default Value [Unit]
SLOPE	Slope in Control Range	real	0 [Pa/(m ³ /s)]

[Top](#)

Input/Output Quantities

Table 3

Name	Description	Data type
POPEN	Opening Pressure [Pa]	real
P	Differential Pressure [Pa]	real

Q	Flow Rate [m ³ /s]	real
---	-------------------------------	------

[Top](#)

Example

In this example, when the Pressure output of the Pressure Source P1 reaches the predefined level POPEN, the Spring Loaded Valve VALVE_NR_SPR1 allows the flow in the outlet direction while blocks it in the other direction. The schematic of the system is shown in Figure 3, system parameters are listed in Table 4, and the simulation results are shown in Figure 4.

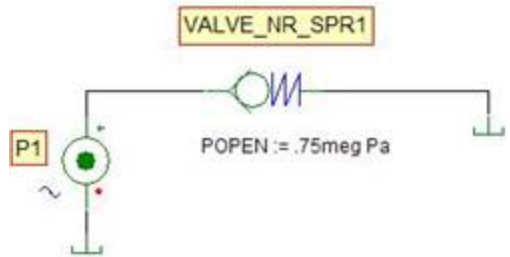
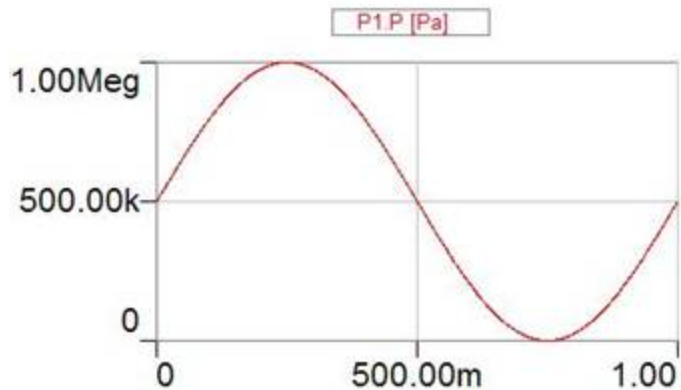

Figure 3. Application example of the Spring LoadedValve model

Table 4. System Parameters

Component	Parameter	Value [unit]
Pressure Source P1 (Time Controller_ Sine)	Amplitude	500K [Pa]
	Frequency	1 [Hz]
	Delay	0 [s]
	Phase	0 [Deg]
	Offset	0.5Meg [Pa]
Spring-Loaded Valve VALVE_NR_ SPR1	POPEN	0.75Meg [Pa]
	SLOPE	1G [Pa/ (m ³ /s)]



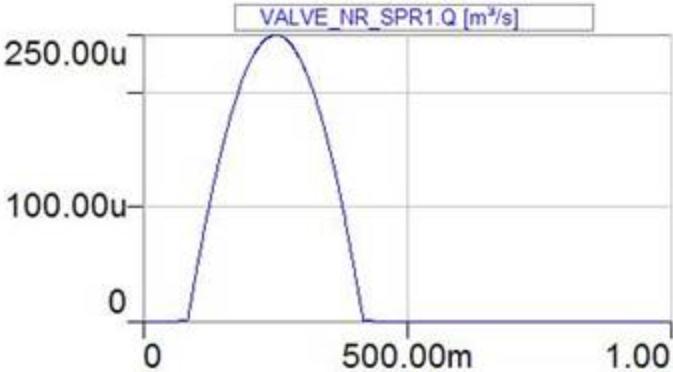

Figure 4. Simulation results

[Top](#)

References

Pressure Control Valves

Pressure Control Valves control the pressure in the valve inlet at the pressure set point. This library contains the following model:

- [Pressure Relief \(VALVE_REL\)](#)

Pressure Relief Valve

Library: Hydraulic

Modeling Language: SML

Version Number: Twin Builder 2024.2

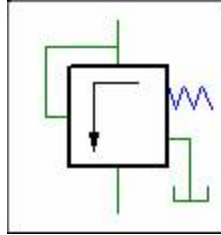

Figure 1. Component symbol

- [Description](#)
- [Assumptions and Limitations](#)
- [Mathematical Description](#)
- [Netlist Syntax](#)
- [Conservative Pins](#)
- [Parameters](#)
- [Input/Output Quantities](#)
- [Example](#)
- [References](#)

Description

The Pressure Relief Valve controls the pressure in the valve inlet at the pressure set point $PSET$ depending on the applied pressure P . The $SLOPE$ is limited to 100m to avoid numerical instabilities.

[Top](#)

Assumptions and Limitations

[Top](#)

Mathematical Description

For control pressure $P < PSET$, the valve is closed. Any pressure is possible at the valve input.

For control pressure $P > PSET$, the valve opens with a steep opening characteristic, so that the input pressure falls to a very low value.

The valve is used, for example, in pressure supply equipment with constant delivery pump combinations for energy saving. Since the valve has no switching hysteresis, a hydraulic fluid reservoir is required in such circuits for stable working.

$$\text{If } P \geq P_{LIMIT} \quad Q = \frac{P - P_{LIMIT}}{SLOPE}$$

$$\text{If } P < P_{LIMIT} \quad Q = \frac{P}{10^{14}}$$

$$P_{LIMIT} \approx (PSET - P(H2)) \geq 0$$

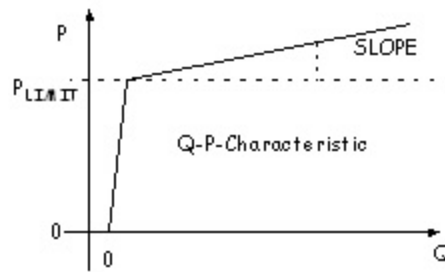

Figure 2. Q-P characteristic of the Pressure Relieve Valve

[Top](#)

Netlist Syntax

```
MODEL VALVE_REL ?InstanceName(@InstanceName):(@ (Refbase)@(ID)) H1:= %0, H2:= %1 ( PSET:= @PSET, SLOPE:= @SLOPE) SRC: DB(Lib:=@ModelLibraryName);
```

[Top](#)

Conservative Pins

Table 1

Name	Port/Terminal description	Nature/Data type
H1	Fluidic Pin	Fluidic terminal
H2	Fluidic Pin	Fluidic terminal

[Top](#)

Parameters

Table 2

Name	Description	Data Type	Default Value [Unit]
------	-------------	-----------	----------------------

SLOPE	Slope in Control Range	real	0.5G [Pa/(m ³ /s)]
-------	------------------------	------	-------------------------------

[Top](#)

Input/Output Quantities

Table 3

Name	Description	Data type
PSET	Set Pressure [Pa]	real
P	Differential Pressure [Pa]	real
Q	Flow Rate [m ³ /s]	real
POWER	Power [W]	real

[Top](#)

Example

In this example, the flow output of the Flow Source Q1 increases linearly with time. When the pressure reaches the predefined level PSET, the valve VALVE_REL1 opens and the flow through the Orifice RHYD1 stays almost constant. The schematic of the system is shown in Figure 3, system parameters are listed in Table 4, and the simulation results are shown in Figure 4.

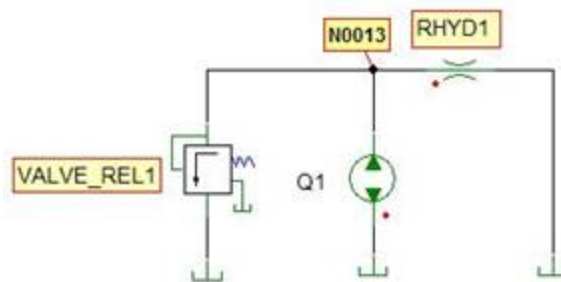

Figure 3. Application example of the Pressure Relieve Valve model

Table 4. System Parameters

Component	Parameter	Value [unit]
Flow Source Q1	VALUE	30m*t [m ³ /s]
Pressure Relieve Valve VALVE_REL1	PSET	1Meg [Pa]
	SLOPE	1E6 [Pa/(m ³ /s)]
RHYD1	K	10n [m ³ /(Pa s)]

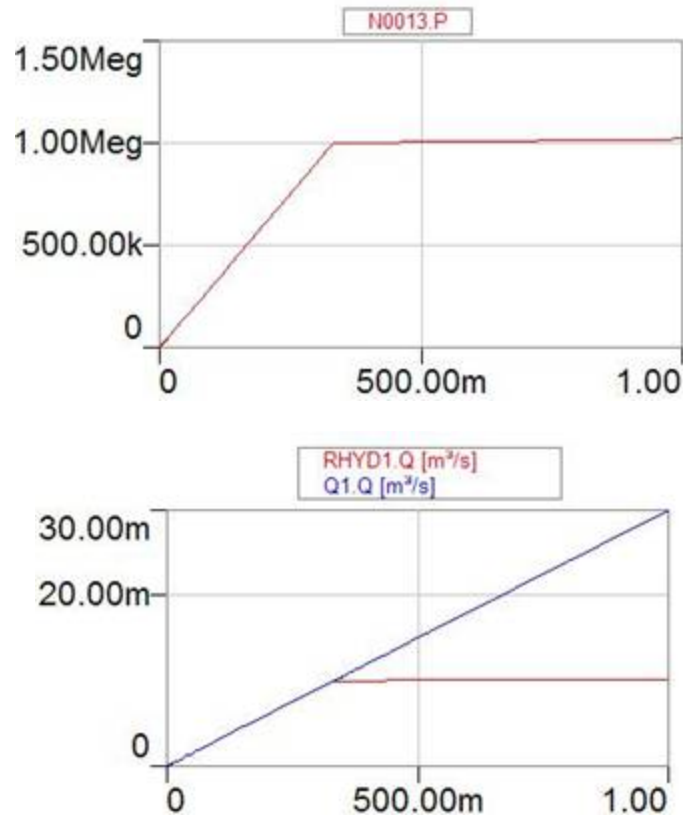

Figure 4. Simulation result

[Top](#)

References

Index

- A**
- Accumulators 1-6
 - Across and Through Quantity of the Fluidic Domain 1-5
 - Actuators 1-20
 - Annular Orifice 1-45
- B**
- Blind Plug 1-74
- C**
- Characteristic Orifice 1-64
- D**
- Directional Control Valves, 2-2 1-110
 - Directional Control Valves, 3-2 1-114
 - Directional Control Valves, 4-2 1-118
 - Directional Control Valves, 4-3 1-125
 - Double-Acting Actuator 1-21
- E**
- Equal Movement Cylinder 1-29
- F**
- Flow Source 1-84
 - Flowmeter 1-42
- G**
- Gas-Charged Adiabatic Accumulator 1-16
 - Gas-Charged Isothermal Accumulator 1-7
- H**
- Hydraulic Reference Arrow System 1-4
 - Hydraulic Sources 1-77
 - Hydraulic Switches 1-85
 - Hydraulic Valves 1-107
- I**
- Ideal Switch, Change Over 1-97
 - Ideal Switch, Normally Closed 1-94
 - Ideal Switch, Normally Open 1-101
- L**
- Laminar Orifice 1-63
 - Limit Switch 1 1-86
 - Limit Switch 2 1-88
 - Limit Switch 3 1-90
 - Limit Switch 4 1-92
- M**
- Manometer 1-38

Manometer (1Pin) 1-39

N

Non-Return-Valve, Spring-Loaded
1-131

O

Orifices 1-44

P

Pipe 1-69

Pressure Relief Valve 1-136

Pressure Source 1-78

Pressure Switch 1-104

Pump 1-79

S

Sharp-Edge Orifice 1-49

Single-Acting Actuator 1-33

Spring-Loaded Accumulator 1-11

T

Turbulent Orifice 1-54

V

Variable Orifice 1-57

Volume 1-68

W

Wattmeter 1-43